

ADEMCO MX8000
Digital Alarm Receiver

Installation and Operation Guide

Table of Contents

Section 1	System Overview	1-1
1.1	Features	1-1
1.2	Optional Accessories.....	1-1
1.3	Formats Compatible with the MX8000.....	1-2
1.4	MX8000 Supported SIA Digital I-III Levels.....	1-3
1.5	How to Use this Manual	1-3
1.6	Terminology	1-4
1.7	What's in the Box	1-4
1.8	General Recommendations, Notes, and Limitations	1-5
1.9	How to Contact Technical Support.....	1-8
Section 2	Agency Requirements	2-1
2.1	Telephone Requirements.....	2-1
2.2	FCC Statement.....	2-1
2.3	Industry Canada Statements.....	2-1
2.4	UL Requirements	2-2
2.4.1	Hardware Requirements	2-2
2.4.2	Operational Requirements.....	2-3
2.4.3	Programming Requirements	2-3
Section 3	Installation	3-1
3.1	Quick Start	3-1
3.2	Environmental specifications.....	3-1
3.3	Electrical Specifications	3-1
3.4	Overview.....	3-2
3.5	Rack Mounting.....	3-3
3.6	Hot Swapping of Line Cards.....	3-4
3.7	Line Card Installation.....	3-5
3.8	Removing Line Cards.....	3-7
3.9	Telephone Line Connection.....	3-7
3.10	Parallel Printer Connection	3-7
3.10.1	Printer Cable Pin-Outs	3-8
3.10.2	Com Ports 1 and 2	3-9
3.10.3	Remote Alert Output.....	3-9
3.11	AC Power Cord Connection	3-9
3.11.1	Switching to a 240 VAC Power Supply.....	3-9
3.11.2	How to Verify Earth Ground.....	3-10
3.12	Battery Connection	3-11
3.13	Automation Computer Connection	3-12
3.13.1	Computer Port Baud Rate Selection	3-12
3.14	Master/Slave Receiver Linking.....	3-12
3.14.1	Receiver Linking Cabling Connections	3-12
3.14.2	Master/Slave Linking Programming	3-13
Section 4	Operation	4-1
4.1	Touchpad Function Buttons.....	4-1
4.2	Displays	4-2
4.2.1	LED Displays	4-3
4.2.2	VFD Status Display.....	4-3
4.3	Initial System Power Up.....	4-4
4.4	Log On / Log Off.....	4-5
4.4.1	Installer Profile	4-5
4.4.2	Operator Profile	4-5
4.4.3	Default User Codes	4-5
4.4.4	How to log on the system.	4-5
4.4.5	How to log off the system.	4-6
4.5	Modes of Operation	4-6
4.5.1	Normal Mode	4-6
4.5.2	Program Mode.....	4-7

4.6	Main Menu	4-7
4.6.1	How to Display the Main Menu	4-7
4.6.2	How to Maneuver Through Main Menu	4-8
4.6.3	Call History	4-8
4.6.4	System History	4-9
4.6.5	System Info	4-9
4.6.6	Set Time & Date	4-9
4.6.7	System Restart	4-10
4.6.8	Printer Menu	4-11
4.6.9	Program Menu	4-16
4.6.10	Diagnostics Menu	4-16
4.7	Listen-In and Hang Up	4-19
4.7.1	Extend Manual (Common) Listen-In Operation	4-19
4.7.2	PBX Operation	4-20
4.8	Testing the System	4-20
Section 5	Programming	5-1
5.1	How to Enter Program Mode	5-1
5.1.1	Programming Fields	5-1
5.1.2	How to Maneuver Around in Program Mode	5-1
5.2	Programming Choices	5-2
5.3	General Options	5-2
5.3.1	Operation Mode	5-6
5.3.2	Display Options	5-7
5.3.3	Communications	5-11
5.3.4	System Options	5-21
5.3.5	Message Queue Options	5-24
5.3.6	Slave List	5-25
5.3.7	Virtual Receiver/Line Numbers	5-26
5.4	Line Device Menu	5-27
5.4.1	Add Line Device	5-37
5.4.2	Edit Line – MX8000–LC3 (3 Line)	5-37
5.4.3	Edit Line – MX8000–LRR	5-52
5.4.4	Edit Line – MX8000–LC1 (1 Line)	5-55
5.4.5	Copy Device(s)	5-67
5.4.6	Clear Device	5-69
5.4.7	View Devices	5-69
5.5	User List	5-70
5.5.1	Adding a User	5-70
5.5.2	Editing a User	5-71
5.5.3	Clearing a User Out of the Receiver	5-72
Section 6	Compatible Reporting Formats	6-1
6.1	Formats By Communication Group	6-1
6.2	Format Numbers Used In Printer Output	6-3
Section 7	Troubleshooting	7-1
7.1	Error Messages	7-1
7.2	Unrecognized Reports	7-4
7.3	Troubleshooting Process	7-4
7.3.1	Removing the CPU, PS, User Interface Assembly	7-5
7.3.2	Replacing the CPU, PS, User Interface Assembly	7-5
7.4	Safe Mode	7-5
Section 8	Automation Communication Formats	8-1
8.1	Introduction	8-1
8.1.1	Conventions Observed In This Section	8-1
8.2	MX8000 Automation Protocols	8-1
8.3	Reporting Formats and Automation Protocol Support	8-2
8.4	ADEMCO 8000	8-3
8.4.1	AE Header Block	8-3
8.4.2	Call Message Block	8-3
8.4.3	System Message Block	8-7

8.4.4	Heart Beat Message Block.....	8-8
8.4.5	Validation Byte (V-Byte).....	8-9
8.4.6	ACKing and NACKing Data.....	8-9
8.4.7	Commands Initiated by the Automation Computer.....	8-9
8.5	ADEMCO 685 Automation Protocol.....	8-13
8.5.1	Low Speed 3x1, 4x1, and 4x1 Express Automation Protocols.....	8-13
8.5.2	Low Speed 4x2 and 4x2 Express Automation Protocols.....	8-13
8.5.3	ADEMCO High Speed Automation Protocols.....	8-13
8.5.4	685 Contact ID.....	8-14
8.5.5	MX8000/685 System Messages.....	8-20
8.6	CAPS Automation Protocol.....	8-20
8.7	FBII CP-220 Automation Protocol.....	8-22
8.7.1	3x1, 4x1, and 4x2 Automation Protocols.....	8-22
8.7.2	Acron 11 Digit with Zero or Space.....	8-22
8.7.3	FBII Superfast.....	8-22
8.7.4	CP-220 Contact ID.....	8-22
8.7.5	CP-220/Silent Knight.....	8-23
8.7.6	MX8000/CP-220 System Messages.....	8-24
8.8	SK9000 Protocol.....	8-25
8.8.1	Data String Description And Special Characters.....	8-25
8.8.2	Calls From Panels.....	8-26
8.8.3	Long Calls.....	8-26
8.8.4	Bad Data.....	8-27
8.8.5	Good Data with Bad Data.....	8-27
8.8.6	Validation Byte (V-Byte).....	8-27
8.8.7	System Messages.....	8-28
8.8.8	Communication from a Computer to the MX8000.....	8-28
8.9	ITI Generic Computer Format.....	8-29
8.9.1	Convention Used In This Section.....	8-29
8.9.2	Report Record.....	8-29
8.9.3	Log Record.....	8-31
8.9.4	Test Record.....	8-32
8.9.5	OKAY Record.....	8-32
8.9.6	ACKing and NACKing Data.....	8-32
8.10	ITI Computer Interface Format.....	8-32
8.10.1	Convention Used In This Section.....	8-32
8.10.2	General Record Structure.....	8-33
8.10.3	Report Record.....	8-33
8.10.4	Test Record.....	8-36
8.10.5	Supervisory Record.....	8-37
8.10.6	Log Records.....	8-37
8.10.7	Checksum/Control Field.....	8-37
8.11	US ASCII Character Code.....	8-38
Appendix A	Programming Quick Chart.....	A-1
Appendix B	Receiver Update Procedure.....	B-1
Appendix C	Index.....	C-1

List of Tables

Table 1–1: Optional Accessories for the MX8000 Receiver	1–2
Table 1–2: Formats Compatible with the MX8000	1–2
Table 1–3: MX8000 and SIA Levels I-III comparison	1–3
Table 3–1: External Printer Cable Pin Description	3–8
Table 4–1: Touchpad Buttons Description	4–2
Table 4–2: LED Description	4–3
Table 4–3: VFD and Printer Abbreviations	4–4
Table 4–4: Main Menu Option Items by Profile	4–5
Table 4–5: Default User Codes	4–5
Table 4–6: Printer Menu Choices	4–11
Table 4–7: Event Format Choices and Meaning	4–14
Table 4–8: Phantom Signals Formats List	4–16
Table 4–9: Abbreviation Display Character Meanings/High Low Status	4–19
Table 5–1: Types of Programming Fields	5–1
Table 5–2: General Options Items and Description	5–3
Table 5–3: Operation Mode Choices and Descriptions	5–6
Table 5–4: Display Options and Descriptions	5–7
Table 5–5: Communications Options and Description	5–11
Table 5–6: Initialization String Characters	5–16
Table 5–7: ITI Automation Format Options	5–19
Table 5–8: On-board Annunciator and Auxiliary Relay Options	5–20
Table 5–9: System Options	5–21
Table 5–10: 685, CAPS, and CP-220 1–9/A–Z Entries	5–22
Table 5–11: Line Device Menu Options	5–28
Table 5–12: MX8000–LC3 Edit Line List Items and Description	5–38
Table 5–13: Valid Programmable String Characters	5–43
Table 5–14: Account Characters	5–44
Table 5–15: Hexadecimal AlarmNet Number to Decimal Conversion	5–54
Table 5–16: MX8000–LC1 Edit Line List Items and Description	5–55
Table 5–17: User List Menu Items and Steps	5–70
Table 5–18: Available Characters	5–71
Table 6–1: Formats compatible with the MX8000	6–1
Table 6–2: Formats By Report Number	6–3
Table 7–1: Error Messages	7–1
Table 8–1: Automation Protocol Listing	8–1
Table 8–2: Reporting Formats and Automation Protocol Support	8–2
Table 8–3: AE Header Block Components Description	8–3
Table 8–4: Call Message Components and Description	8–3
Table 8–5: Dialer Format Types By Code	8–4
Table 8–6: Panel Data Identifiers and Descriptions	8–4
Table 8–7: Call Message Components	8–5
Table 8–8: Call Message With Listen-in Data	8–6
Table 8–9: Bad Data Field Indicator Components	8–7
Table 8–10: System Message Components	8–7
Table 8–11: System Messages	8–8
Table 8–12: Link Test Components	8–9
Table 8–13: Response Messages by the MX8000 Receiver	8–10
Table 8–14: Command Requests by Identifiers	8–10
Table 8–15: Log-in Request Components	8–10
Table 8–16: Log-off Request Components	8–11
Table 8–17: Force Hang-Up Request Components	8–11
Table 8–18: Add Listen-in Account Request Components	8–11
Table 8–19: Delete a Listen-in Account Request Components	8–11
Table 8–20: Extend Listen-in Period Request Components	8–12
Table 8–21: End Listen-in Period Request Components	8–12

Table 8–22: Delete a Listen-in Account Request Components	8–12
Table 8–23: Contact ID Event Definition Codes	8–15
Table 8–24: MX8000/685 System Messages	8–21
Table 8–25: MX8000/CP-220 System Messages	8–24
Table 8–26: Data String Description	8–25
Table 8–27: Special Characters Used in the Protocol	8–25
Table 8–28: System Messages	8–28
Table 8–29: Number and ITI Digit Equivalent	8–29
Table 8–30: Report Record Components	8–29
Table 8–31: Upper Nibble Description	8–30
Table 8–32: Lower Nibble Description	8–30
Table 8–33: Extended Panel ID Codes (XID)	8–30
Table 8–34: Alarm Code and Description	8–31
Table 8–35: Log Record Components and Description	8–31
Table 8–36: Test Record Components and Description	8–32
Table 8–37: Okay Record Components and Description	8–32
Table 8–38: Number and ITI Digit Equivalent	8–33
Table 8–39: Type of Record Identifiers	8–33
Table 8–40: Record Components	8–33
Table 8–41: Report Record Components and Description	8–34
Table 8–42: Information Field Identifiers	8–34
Table 8–43: Panel Type Characters	8–35
Table 8–44: Condition Codes and Descriptions	8–36
Table 8–45: Test Record Information Fields and Descriptions	8–36
Table 8–46: Log Record Information Fields and Descriptions	8–37
Table 8–47: Checksum Verification Process	8–38
Table 8–48: US ASCII Character Code	8–38
Table A–1: Programming Quick Chart	A–1

List of Figures

Figure 3–1: MX8000 Front View	3–2
Figure 3–2: MX8000 Front View Without Front Plate Attached	3–2
Figure 3–3: MX8000 Rear View	3–2
Figure 3–4: Rack Mount Enclosure, Front View	3–3
Figure 3–5: Rack Mount Enclosure, Rear View	3–4
Figure 3–6: Line Card Locations	3–5
Figure 3–7: Line Card Position and Components	3–6
Figure 3–8: Parallel Printer Cable Connection to MX8000	3–8
Figure 3–9: Wiring Sequence For Parallel Printer Port Interface	3–8
Figure 3–10: MX8000 Remote Alert Output/Backup Battery Connection	3–9
Figure 3–11: CPU, PS, User Interface Assembly Retaining Screw Locations	3–10
Figure 3–12: Side View of CPU, PS, User Interface Assembly	3–10
Figure 3–13: Outlet Voltage Measurement Points	3–11
Figure 3–14: Battery Connections	3–11
Figure 3–15: 25-Pin Null Modem Cable Connection	3–12
Figure 3–16: 9-Pin Null Modem Cable Connection	3–12
Figure 3–17: MX8000 Master/Slave Receiver Linking Cabling Connections	3–13
Figure 3–18: SBUS Receiver Linking Cable	3–14
Figure 4–1: MX8000 Front Panel	4–1
Figure 4–2: Touchpad Layout	4–1
Figure 4–3: VFD Display	4–3
Figure 4–4: Power-up Routine	4–4
Figure 4–5: Main Menu Display	4–7
Figure 4–6: Main Menu Controls	4–8
Figure 4–7: View of a Call History Screen	4–8
Figure 4–8: System History Display Sequence	4–9
Figure 4–9: System Information Display	4–9
Figure 4–10: Setting Time and Date Program Sequence	4–10
Figure 4–11: System Restart Display	4–10
Figure 4–12: Print Menu Items	4–11
Figure 4–13: Print Report Menu Items	4–12
Figure 4–14: Call History Options	4–12
Figure 4–15: System Configuration Print Items	4–13
Figure 4–16: Event Format Menu Items	4–14
Figure 4–17: Program Menu Items	4–16
Figure 4–18: Diagnostics Menu Items	4–16
Figure 4–19: Message Queue Level	4–17
Figure 4–20: Event Log Display	4–17
Figure 4–21: Diagnostic Formats	4–17
Figure 4–22: Select LC Debug Mode by Line Card	4–17
Figure 4–23: Line Statistics Display	4–18
Figure 4–24: Port Status View of Serial Port	4–18
Figure 4–25: Parallel Port Status View	4–18
Figure 4–26: Phone Connector Pin-Out and Listen-in Wiring Diagram	4–20
Figure 5–1: Programming Controls	5–2
Figure 5–2: Program Menu Choices	5–2
Figure 5–3: General Options Display	5–2
Figure 5–4: Normal Operating Mode Display Indicating Manual Operation	5–6
Figure 5–5: View of Display Options	5–7
Figure 5–6: Communications Options Menu	5–11
Figure 5–7: Initialization String Display	5–15
Figure 5–8: System Options Display	5–21
Figure 5–9: Message Queue Display	5–24
Figure 5–10: Slave List Display	5–25
Figure 5–11: Virtual Receiver/Line Numbers Display	5–26

Figure 5–12: Choosing Line Device Menu and Line Device Program Menu Items	5–27
Figure 5–13: MX8000–LC3 Handshake Sequence Menu	5–38
Figure 5–14: MX8000–LC3 Handshake Order Number	5–38
Figure 5–15: MX8000–LC3 Line Options Menu	5–41
Figure 5–16: MX8000–LC3 Listen Mode Menu Display	5–43
Figure 5–17: MX8000–LC3 Listen In Accounts Menu	5–44
Figure 5–18: MX8000–LC3 Miscellaneous Phone Line Options	5–45
Figure 5–19: MX8000–LC3 Ring Options	5–47
Figure 5–20: MX8000–LC3 ADEMCO Auto Output Options	5–48
Figure 5–21: MX8000–LC3 Line Gain Options	5–50
Figure 5–22: MX8000–LRR Line Edit	5–53
Figure 5–23: MX8000–LC1 Handshake Sequence Menu	5–56
Figure 5–24: MX8000–LC1 Handshake Order Number	5–56
Figure 5–25: MX8000–LC1 Line Options Menu	5–59
Figure 5–26: MX8000–LC1 Listen Mode Menu Display	5–61
Figure 5–27: MX8000–LC1 Listen In Accounts Menu	5–63
Figure 5–28: MX8000–LC1 Miscellaneous Phone Line Options	5–64
Figure 5–29: MX8000–LC1 ADEMCO Auto Output Options	5–66
Figure 5–30: Visual Steps to Clear a Line From the Receiver	5–69
Figure 5–31: User List Menu Items	5–70
Figure 7–1: User CPU, PS, User Interface Assembly retaining Screw Locations	7–5
Figure 8–1: 685 3x1, 4x1, 4x1 Express Protocol	8–13
Figure 8–2: 685 4x2 and 4x2 Express Protocol	8–13
Figure 8–3: 685 ADEMCO High Speed Protocol	8–14
Figure 8–4: 685 Contact ID Protocol	8–14
Figure 8–5: CAPS 4x2 and 4x2 Express Protocol	8–20
Figure 8–6: CP-220 3x1, 4x1, 4x2 Protocol	8–22
Figure 8–7: CP-220 Acron 11 Digit Protocol	8–22
Figure 8–8: CP-220 FBII Superfast Protocol	8–22
Figure 8–9: CP-220 Contact ID Protocol	8–23
Figure 8–10: CP-220/Silent Knight Format 0	8–23
Figure 8–11: CP-220/Silent Knight Format 1 (FSK 1)	8–23
Figure 8–12: CP-220/Silent Knight Format 6 (FSK 2)	8–24
Figure 8–13: SK9000 Example Message	8–26
Figure 8–14: Long Event Data	8–27
Figure 8–15: System Message	8–28

Section 1 System Overview

This manual describes installation, operation, and programming of the MX8000 Digital Alarm Receiver. The MX8000 can be used as a desktop receiver, however it must be rack-mounted for UL Listed installations. This section will list features, optional accessories, compatible formats, and SIA options supported. This section also contains conventions held throughout the manual, terminology relevant to this product, and other information.

To ensure the best possible performance from this product, please check the Honeywell Online Support web site ([HTTP://WWW.HONEYWELL.COM/SECURITY](http://www.honeywell.com/security)) for the latest code upgrades before placing this product into service.

1.1 Features

Hardware:

- Supports both 120 and 240 VAC installations at 60 and 50Hz operation.
- External annunciation with auxiliary Form C dry contact relay. (Programmable)
- On-board programmable piezo alert sounder.
- 1 parallel port.
- 2 serial ports.
- 2 rear SBUS connectors.
- Modular configuration for easy replacement and repair.
- 4 line Vacuum Fluorescent Display (VFD) with 20 characters for each line.
- On-board touchpad for manual operation and programming.
- LEDs to indicate system operations.
- Rack mountable design.
- One line card will communicate with all supported formats.
- Supports up to 12 3-port line cards where the ports operate independent of each other.
- Line Device parameters are stored in the Master Central Processing Unit for faster removal and replacement.
- Line Devices support Caller ID.
- Line Devices are individually programmable for format priority and ring parameters.
- Line Devices support direct connect phone lines monitoring.

Software:

- Programmable display options for time and date information.
- View or print the history information by priority or by call or by event.
- Two user profiles to control user access to the receiver.
- Supports up to 40 users.
- Listen-in accounts support wild card variables.
- Listen-in selectable for direct, hook flash, or PBX phone system.
- Programmable port configuration for automation, printer and backup support.
- 500 event history buffer.

1.2 Optional Accessories

Table 1–1 lists optional accessories for the MX8000 receiver. These accessories are available from our sales department unless otherwise indicated.

Table 1–1: Optional Accessories for the MX8000 Receiver

Item	ADEMCO Model Number (if applicable)	Description/Comments
Three Line card	MX8000–LC3	The 3 line card monitors the phone lines, detects ring and processes the message from the communicating panel.
One Line card	MX8000–LC1	The 1 line card monitors a phone line, detects ring and processes the message from the communicating panel.
Radio Line card	MX8000–LRR	The radio line card interfaces to a transceiver and processes the message from the communicating panel.
CPU, PS, User Interface	MX8000–CPU	The CPU, Power Supply, User Interface Assembly contains the VFD, main processing board, and receiver power supply.
Backup battery	Acquire from a local retailer (See Section 3.12 for installation.)	A UL Fire Protection Services approved 12VDC 7AH battery such as a Powersonic PS-1270 that will provide a minimum 4 hours of backup power during an AC power loss. (See Section 2.4.2 for UL backup power requirements.)
Printer cable	Acquire from a local retailer	A standard 25-pin cable used to connect the MX8000 receiver to an external parallel printer.
SBUS cable	Acquire from a local retailer	A standard 4-wire RJ-11 reverse cable such as a Digi-Key H2642-14-ND that is used to connect the receivers together for receiver linking.
Rack-mounting cabinet	Acquire from a local retailer	Used to rack mount the MX8000 receiver as required by UL. (See Section 2.4.1 for specifications and vendor information.)
Blank filler panels	Acquire from a local retailer	Used to fill up any unused cabinet spaces as required by UL.
Parallel printer	Acquire from a local retailer	The ADEMCO MX8000 receiver requires a UL approved dot matrix parallel printer such as the Okidata Microline 320 to generate a hardcopy of report history.

1.3 Formats Compatible with the MX8000

The MX8000 receiver is compatible with all ADEMCO UL Listed communicators. Table 1–2 shows the formats that the MX8000 receiver can decode and the handshake frequency groups that accommodate that format (see Section 5.4 for line device programming). Each line device can decode every format listed below. Setting the handshake order only prioritizes the type of communication done by each line device. Section 6 of this manual describes the formats in greater detail.

Important Note: When selecting a reporting format and using an automation computer, it is essential that you check Table 8–2: Reporting Formats and Automation Protocol Support to verify that the reporting format selected is supported by the automation protocol that will be used.

Table 1–2: Formats Compatible with the MX8000

REPORTING FORMAT		PPS or CPS	REPORTING FORMAT		PPS or CPS	
1400/2300 Hz Pulse	3/1, 3/1 Ext	10, 20, or 40 PPS	FSK (cont'd)	ITI UltraGard	N/A	
	3/1 Even Round	10, 20, or 40 PPS		Radionics Modem II	N/A	
	3/1 w/cksum	10, 20, or 40 PPS		Radionics Modem IIE	N/A	
	3/1 Ext w/cksum	10, 20, or 40 PPS		SIA DCS	N/A	
	3/2	10, 20, or 40 PPS		SX-III, SX-IVA	N/A	
	3/2 Even Round	10, 20, or 40 PPS		SX-IVB	N/A	
	3/2 w/cksum	10, 20, or 40 PPS		Varitech FSK 4/1	N/A	
	4/1, 4/1 Ext	10 PPS		Varitech FSK 4/2	N/A	
	4/1 Even Round	10 PPS		DTMF	Acron Touchtone w/ 3-digit account	10 CPS
	4/1 w/cksum	10 PPS			Acron Touchtone w/ 4-digit account	10 CPS
	4/1 Ext w/cksum	10 PPS			ADEMCO 4/1 w/cksum	10 PPS
	4/2	10 PPS			ADEMCO 4/2 w/cksum	10 PPS
	4/2 Even Round	10 PPS			ADEMCO High Speed	10 CPS
	4/2 w/cksum	10 PPS			ADEMCO High Speed w/cksum	10 CPS
BFSK	N/A	Contact ID®	10 CPS			
FSK0/FSK 80	N/A	Contact ID®10	10 CPS			
FSK1/FSK 81	N/A	FBII 4/3/1	10, 20, or 40 PPS			
FSK2/FSK 86	N/A	FBII 4/3/1 w/cksum	10, 20, or 40 PPS			
ITI CareTaker+, SecurityPro 4000	N/A	FBII Superfast				
ITI Commander	N/A	Westec 970	10 CPS			
ITI Commander 2000, LifeGard	N/A	Westec 1000/2000/3000	10 CPS			
ITI RF Commander, Harbor Gard	N/A					
ITI SX-V	N/A					

1.4 MX8000 Supported SIA Digital I-III Levels

Table 1–3 compares the MX8000 receiver to SIA Digital Compatibility Levels I, II, and III and indicates which of them we comply with.

Table 1–3: MX8000 and SIA Levels I-III comparison

		8000	Function/Capability	Transmitter	Receiver	
Level I	Level II	✓	Support Tonal Acknowledgments	required	required	
		✓	Support N blocks with Zone Numbers Only	required	required	
		✓	Support single Account Block per Call	required	required	
		✓	Support O Blocks	(optional)	required	
		✓	Support X Blocks	(optional)	required	
		✓	Support 300 Baud (Fast)	(optional)	required	
	Level III			Support Configuration Block	required	required
				Support Data Acknowledgments	required	required
		✓		Support Modifier codes <i>id</i> , <i>da</i> and <i>ti</i> .	(optional)	required
		✓		Support Multiple Account Blocks per Call	(optional)	required
		✓		Support E Blocks	(optional)	required
		✓		Support Data Codes with Units Numbers	(optional)	required
				Support RECEIVER call out and Access Passcode	required	required
				Support Reverse Channel C Blocks	required	required
				Support Reverse Channel P Blocks	required	(optional)
				Support Reverse Channel A Blocks	(optional)	required
				Support Dynamic block and Group Sizes	(optional)	required
		✓		Support Listen-in	(optional)	required
✓		Support A Blocks to RECEIVER	(optional)	required		
		Support V-Channel communication	(optional)	(optional)		

1.5 How to Use this Manual

This manual contains information on how to install, operate and program the MX8000 receiver. We strongly suggest that the manual be reviewed in its entirety to become familiar with procedures and parameters of the product. Once you are familiar with the product, the manual can be used as a reference document.

This manual uses the following conventions:

- A small graphic of each touchpad button is used to represent which touchpad key is to be pressed for a given operation. For example, an up-arrow would be shown as: 
- VFD display This represents messages that appear on the VFD (display).
- **2225Hz** This typeface represents an editable field that appears on the VFD (display).
- Pages of the manual are numbered by section. For example, a page numbered as “5-1” is Page 1 of Section 5.
- When this manual refers to default settings, it means programmable options set at the factory. Any programming after the receiver is powered up will change these setting.

1.6 Terminology

This section lists terminology that is specific to this product and their meaning.

Term	Meaning
ACK	Stands for acknowledgment.
Automation Protocol	The format used for messages sent between the receiver and the automation computer.
Communication Group	The different types of communication are separated by handshake type. These handshake types can be assigned in a numbered order. (See Section 5 for more details.)
Heartbeat	A supervisory signal that continually tests the communication link between the automation computer and the receiver.
Listen-in	Listen-in is the ability to listen in to what is happening real-time from the central station to a remote location. This can help the central station operator determine if he or she should dispatch for a particular alarm situation.
Main Menu	The main menu will be displayed as either <input type="button" value="<Installer Menu>"/> or <input type="button" value="<Operator Menu>"/> . However, this manual will refer to them as the main menu.
MCPU	Master Central Processing Unit.
NACK	Stands for no acknowledgment.
PIN	An abbreviation for Personal Identification Number. PINs are used to log in and out of the receiver.
PZT	PZT is an abbreviation for a piezo alert sounder.
SBUS	Serial Bus interface to connect a MX8000 receiver to line cards, the VFD display and additional MX8000 receivers via rear panel connectors.
VFD	Stands for Vacuum Fluorescent Display. This is the type of message display used on the receiver.
VPN	Stands for Virtual Private Network. VPN is a feature available with the MX8000-LRR line card and allows an increase in the number of accounts (in increments of 10,000) that can report to one LRR. When this feature is not used, the number of accounts that can report to one LRR is limited to 10,000.

1.7 What's in the Box

This section contains a list of the parts that are shipped with the MX8000 receiver and a brief description of their intended use.

Item	Quantity	Description
Battery/Alert Relay Wiring Harness	1	Wiring harness used to connect the MX8000 receiver to a backup battery. It also provides a normally open or normally closed output for an alert sounder.
MX8000 Installation and Operation Guide	1	A manual covering installation and operation information related to the MX8000 receiver.
Digital Alarm Receiver	1	The digital alarm receiver assembly.
Line Card (See Note)	1	Line card for land lines.
Strain Relief Tie Wrap	1	Tie wrap used as a strain relief on the phone cord. See Figure 3-3 for location of strain relief tabs.
Receiver Mounting Screws	4	#10-32 x 3/8 flat head screws used to mount the receiver to a UL Listed rack. (See Section 3.5 for rack mounting instructions.)
Power Cable	1	AC power cable used to connect the MX8000 receiver to an AC wall plug.
<p>Note: The system is shipped with either of two line cards dependent on the system ordered. If the MX8000-1 is ordered, the line card included is an MX8000-LC1 single line card. If an MX8000-3 is ordered, the line card included is an MX8000-LC3 tri-line card.</p>		

1.8 General Recommendations, Notes, and Limitations

The following listing contains items that it is helpful to be aware of:

- We recommend using the ADEMCO 8000 automation protocol so that you have access to the full system capabilities.
- When outputting to an automation computer and using the MX8000-LRR card, only the 685, CAPS, or ADEMCO 8000 automation protocol may be used.
- Do not mix formats containing the same number of reporting characters on the same line. For example, do not have panels using 3+2 and 4+1 or 4+2 and 4+1 w/checksum reporting on the same line. If the formats are mixed, the MX8000 will not correctly determine the reporting formats being used and incorrect messages will result.
- The MX8000-LC1 Line Card does not support 10-Digit Account Number Contact ID®.
- The receiver must be reset before the automation output will be correct any time the automation protocol is changed or defined.
- When replacing a 685 or CP-220 with an MX8000, make certain that the ADEMCO Auto Options for each line match what was set in the 685 or CP-220. The following chart is provided as an aid in setting these options when converting from a 685.

	685 Option	Location	Default Setting	MX8000 Equivalent Option	Default Setting	Rules / Examples
1	Inhibit translation of 4-2 codes B and C to High Speed ADEMCO	PROM Chart 7, Slot 8	Convert to High Speed	42Out (Normal or High Speed)	High Speed	In High Speed mode, messages with event codes of B and C are translated to High Speed Opening and Closing messages, respectively. For example, the message 1234 B 7 would be translated to: 1234 7222 2222 2.
2	Restore Report Translation to High Speed (code 9)	PROM Chart 8	Not translated	3/1 Rstr - (3/1 or High Speed)	3/1	Standard method: 123 2, 123 9 Converted to High Speed: 0123 5355 5555 7
3	Don't combine 3-1, 4-1 expanded messages	PROM Chart 10, Slot 2	Combined	Pls – (Extended or Not Extended)	Extended	A sequence of 1234 B , BBBB 7 is combined into a 4-2 message of 1234 B7. (Applies to B,C,E,F). This message would either be put out to Automation as 4-2 or High Speed (see #5 below). When the option is selected, the receiver does not combine the expanded messages. They are output in the same form as received.
4	Disable BFSK into High Speed Messages (4-2 instead)	PROM Chart 10, Slot 3	High Speed	BFSK - (4-2 or High Speed)	High Speed	Same as #1 above except that it applies to event codes B, C, E, F.
5	Use 4-2 for output of low speed expanded messages (3-1, 4-1)	PROM Chart 10, Slot 6	Not 4-2	ExtOut (High Speed or 4/2)	High Speed	If low speed expanded messages are received and combined (See # 3 above), the messages are output to Automation as 4-2 or High Speed messages. For example, a sequence of 1234 B , BBBB 7 is combined and output as a 4-2 message of 1234 B7.

- Install the MX8000-LRR radio line card into slot 12 when using the VPN (Virtual Private Network) feature with ADEMCO 8000 automation protocol. Install the MX8000-LRR radio line card into slot 3 when using the VPN feature with 685 or CAPS automation protocol and not using Virtual Receiver/Line

numbers. When using the MX8000-LRR with the VPN feature, 685 or CAPS automation protocol, and Virtual Receiver Line numbers, assign the MX8000-LRR as line 8.

- When using the 685, CAPS, or CP-220 automation protocol, a limit applies to the number of line cards that should be used for proper processing by most automation systems.
 - The following examples apply when NOT using Virtual Receiver/Line numbers while using 685, CAPS, or CP-220 automation protocols and are currently supported by most automation systems.

685 OR CAPS MODES - The example below allows up to 3 MX8000-LC3 cards giving 8 usable lines:

For MX8000-LC3 (If using an LRR card, insert it as a replacement for the LC3 in slot 3.)												
Line Number	1	4	7	10	13	16	19	22	25	28	31	34
MX8000-LC3 (Y = used)	Y	Y	Y	N	N	N	N	N	N	N	N	N
Device Slot	1	2	3	4	5	6	7	8	9	10	11	12
Alarms Report as Lines:	1,2,3	4,5,6	7,8									
Line Faults as Line:	1,2,3	4,5,6	7,8									
Notes:	<ul style="list-style-type: none"> • Cards in slot 4 or higher may not be supported by your automation system when using 685, CAPS, or CP-220 automation protocol. • Cards in slot 4 or higher cannot report alarms or line troubles correctly when ADEMCO 685 or CAPS automation protocol is chosen. • Line 9 in slot 3 may not be used when using 685, CAPS, or CP-220. 											

CP-220 MODE - The example below allows up to 5 MX8000-LC3 cards giving 15 usable lines:

For MX8000-LC3 (LRR card not supported by CP-220 mode.)												
Line Number	1	4	7	10	13	16	19	22	25	28	31	34
MX8000-LC3 (Y = used)	Y	Y	Y	Y	Y	N	N	N	N	N	N	N
Device Slot	1	2	3	4	5	6	7	8	9	10	11	12
Alarms Report as Lines:	1,2,3	4,5,6	7,8,9	A,B,C	D,E,F							
Line Faults as Line:	1,2,3	4,5,6	7,8,9	A,B,C	D,E,F							
Notes:	<ul style="list-style-type: none"> • Cards in slot 6 or higher may not be supported by your automation system when using CP-220 automation protocol. • Cards in slot 6 or higher cannot report alarms or line troubles correctly when CP-220 automation protocol is chosen. 											

685 OR CAPS MODES - The example below allows 3 MX8000-LC1 cards only:

For MX8000-LC1 (If using an LRR card, insert it as a replacement for the LC1 in slot 3.)												
Line Number	1	4	7	10	13	16	19	22	25	28	31	34
MX8000-LC1 (Y = used)	Y	Y	Y	N	N	N	N	N	N	N	N	N
Device Slot	1	2	3	4	5	6	7	8	9	10	11	12
Alarms Report as Lines:	1	4	7									
Line Faults as Line:	1	4	7									
Notes:	<ul style="list-style-type: none"> • Cards in slot 4 or higher may not be supported by your automation system when using 685, or CAPS automation protocol. • Cards in slot 4 or higher cannot report alarms or line troubles correctly when ADEMCO 685 or CAPS automation protocol is chosen. 											

CP-220 MODE - The example below allows 5 MX8000-LC1 cards only:

For MX8000-LC1 (LRR card not supported by CP-220 mode.)												
Line Number	1	4	7	10	13	16	19	22	25	28	31	34
MX8000-LC1 (Y = used)	Y	Y	Y	Y	Y	N	N	N	N	N	N	N
Device Slot	1	2	3	4	5	6	7	8	9	10	11	12
Alarms Report as Lines:	1	4	7	A	D							
Line Faults as Line:	1	4	7	A	D							
Notes:	<ul style="list-style-type: none"> • Cards in slot 6 or higher may not be supported by your automation system when using CP-220 automation protocol. • Cards in slot 6 or higher cannot report alarms or line troubles correctly when CP-220 automation protocol is chosen. 											

The example below allows up to 8 MX8000-LC1 cards but lines 4-8 can only report line troubles as line 8 and this example is only allowable in 685 or CAPS (CP-220 not supported):

For MX8000-LC1 (If using an LRR card, insert it as a replacement for the LC1 in slot 8.)												
Line Number	1	4	7	10	13	16	19	22	25	28	31	34
MX8000-LC1 (Y = used)	Y	Y	Y	Y	Y	Y	Y	Y	N	N	N	N
Device Slot	1	2	3	4	5	6	7	8	9	10	11	12
Hunt Group Setting	01	02	03	04	05	06	07	08				
Alarms Report as Lines:	1	2	3	4	5	6	7	8				
Line Faults as Line:	1	4	7	8	8	8	8	8				
Note:	Cards in slot 4 or higher may not be supported by your automation system when using CP-220 automation protocol.											

- The following configurations apply when using 685, CAPS, or CP-220 automation protocols and are NOT currently supported by most automation systems. This information is presented to provide an understanding of what is sent to an automation system in the event any of these configurations are used.

Important Note: The use of Virtual Receiver / Line Numbers is recommended.

The example below allows up to 12 MX8000-LC3 cards giving 36 usable lines:

For MX8000-LC3 (If using an LRR card, insert it as a replacement for the LC3 in slot 3. LRR card not supported by CP-220 mode.)												
Line Number	1	4	7	10	13	16	19	22	25	28	31	34
MX8000-LC3 (Y = used)	Y	Y	Y	Y	Y	Y	Y	Y	Y	Y	Y	Y
Device Slot	1	2	3	4	5	6	7	8	9	10	11	12
Alarms Report as Lines:	1,2,3	4,5,6	7,8,9	A,B,C	D,E,F	G,H,I	J,K,L	M,N,O	P,Q,R	S,T,U	V,W,X	Y,Z,a
Line Faults as Line: (685,CAPS)	1,2,3	4,5,6	7,8,8	8,8,8	8,8,8	8,8,8	8,8,8	8,8,8	8,8,8	8,8,8	8,8,8	8,8,8
Line Faults as Line: (CP-220)	1,2,3	4,5,6	7,8,9	A,B,C	D,E,F	G,H,I	J,K,L	M,N,O	P,Q,R	S,T,U	V,W,X	Y,Z,a
Note:	When 685 or CAPS automation is chosen, all lines above 8 will report as line 8 for phone line failures and restorals.											

The example below allows 12 MX8000-LC1 cards giving 12 usable lines:

For MX8000-LC1 (If using an LRR card, insert it as a replacement for the LC1 in slot 3. LRR card not supported by CP-220 mode.)												
Line Number	1	4	7	10	13	16	19	22	25	28	31	34
MX8000-LC1 (Y = used)	Y	Y	Y	Y	Y	Y	Y	Y	Y	Y	Y	Y
Device Slot	1	2	3	4	5	6	7	8	9	10	11	12
Alarms Report as Lines:	1	4	7	A	D	G	J	M	P	S	V	Y
Line Faults as Line: (685,CAPS)	1	4	7	8	8	8	8	8	8	8	8	8
Line Faults as Line: (CP-220)	1	4	7	A	D	G	J	M	P	S	V	Y
Note:	When 685 or CAPS automation is chosen, all lines above 8 will report as line 8 for phone line failures and restorals.											

1.9 How to Contact Technical Support

If you have a question or encounter a problem, please do the following before contacting technical support:

- Check all wiring connections.
- Determine that the power supply and/or backup battery are supplying proper voltages.
- Verify your programming information where applicable.
- Note the proper model number of this product, and the version level (if known) along with any documentation that came with the product.
- Note your Honeywell customer number and/or company name.

Having this information handy will make it easier for us to serve you quickly and effectively.

Technical Support:	1-800-645-7492 (8 a.m.-8 p.m. EST)
Digital Alarm Receiver Emergency After Hours Support:	1-800-421-5557 (8 p.m.-8 a.m. EST Monday through Thursday and 8 p.m. Friday through 8 a.m. Monday)
FAXBACK Automated Fax Retrieval System:	1-800-573-0153 or 1-516-921-6704 / ext. 1667
World Wide Web Address:	http://www.honeywell.com/security

Section 2 Agency Requirements

2.1 Telephone Requirements

If requested by the telephone company, the following information must be provided before connecting this device to the phone lines:

A. Manufacturer:	Honeywell International Inc.
B. Model Number:	MX8000
C. FCC Registration Number:	US5GBOT01B46056
D. Type of jack (to be installed by the telephone company):	RJ31X or RJ11X
Ringer equivalence:	0.1B

This device may not be connected directly to coin telephones or party line services.

The telephone company may make changes in its facilities, equipment, or procedures that could affect the operation of the equipment. If this happens, the telephone company will provide advance notice to allow you to make the necessary modifications to maintain uninterrupted service.

2.2 FCC Statement

FCC Class B

Note: This equipment has been tested and found to comply with the limits for a Class B digital device, pursuant to part 15 of the FCC Rules. These limits are designed to provide reasonable protection against harmful interference in a residential installation. This equipment generates, uses, and can radiate radio frequency energy and, if not installed and used in accordance with the instructions, may cause harmful interference to radio communications. However, there is no guarantee that interference will not occur in a particular installation. If this equipment does cause harmful interference to radio or television reception, which can be determined by turning the equipment off and on, the user is encouraged to try to correct the interference by one or more of the following measures:

- reorient or relocate the receiving antenna.
- increase the separation between the equipment and receiver.
- connect the equipment into an outlet on a circuit different from that to which the receiver is connected.
- consult the dealer or an experienced radio/TV technician for help.

2.3 Industry Canada Statements

This Class B digital apparatus complies with Canadian ICES-003.

Cet Appareil numérique de la classe B est conforme à la norme NMB-003 du Canada.

NOTICE: The Industry Canada Label identifies certified equipment. This certification means that the equipment meets telecommunications network protective, operational and safety requirements as prescribed in the appropriate Terminal Equipment Technical Requirements document(s). The Department does not guarantee the equipment will operate to the user's satisfaction.

Before installing this equipment, users should ensure that it is permissible to be connected to the facilities of the local telecommunications company. The equipment must also be installed using an acceptable method of connection. The customer should be aware that compliance with the above conditions might not prevent degradation of service in some situations.

Repairs to certified equipment should be coordinated by a representative designated by the supplier. Any repairs or alterations made by the user to this equipment, or equipment malfunctions, may give the telecommunications company cause to request the user to disconnect the equipment.

Users should ensure for their own protection that the electrical ground connections of the power utility, telephone lines and internal metallic water pipe system, if present, are connected together. This precaution may be particularly important in rural areas.

Caution: Users should not attempt to make such connections themselves but should contact appropriate electric inspection authority, or electrician, as appropriate.

INDUSTRIE CANADA

AVIS: L'étiquette d'Industrie Canada identifie le matériel homologué. Cette étiquette certifie que le matériel est conforme aux normes de protection, d'exploitation et de sécurité des réseaux de télécommunications, comme le prescrivent les documents concernant les exigences techniques relatives au matériel terminal. Le Ministère n'assure toutefois pas que le matériel fonctionnera à la satisfaction de l'utilisateur.

Avant d'installer ce matériel, l'utilisateur doit s'assurer qu'il est permis de le raccorder aux installations de l'entreprise locale de télécommunication. Le matériel doit également être installé en suivant une méthode acceptée du raccordement. L'abonné ne doit pas oublier qu'il est possible que la conformité aux conditions énoncées ci-dessus n'empêche pas la dégradation du service dans certaines situations.

Les réparations de matériel homologué doivent être coordonnées par un représentant désigné par le fournisseur. L'entreprise de télécommunications peut demander à l'utilisateur de débrancher un appareil à la suite de réparations ou de modifications effectuées par l'utilisateur ou à cause de mauvais fonctionnement.

Pour sa propre protection, l'utilisateur doit s'assurer que tous les fils de mise à la terre de la source d'énergie électrique, de lignes téléphoniques et des canalisations d'eau métalliques, s'il y en a, sont raccordés ensemble. Cette précaution est particulièrement importante dans les régions rurales.

Avertissement: L'utilisateur ne doit pas tenter de faire ces raccordements lui-même; il doit avoir recours à un service d'inspection des installations électriques, ou à un électricien, selon le cas.

AVIS: L'indice d'équivalence de la sonnerie (IES) assigné à chaque dispositif terminal indique le nombre maximal de terminaux qui peuvent être raccordés à une interface. La terminaison d'une interface téléphonique peut consister en une combinaison de quelques dispositifs, à la seule condition que la somme d'indices d'équivalence de la sonnerie de tous les dispositifs n'excède pas 5.

2.4 UL Requirements

Follow the procedures outlined in the sections below for listing as an NFPA 72 Central Station Service installation. The MX8000 is also suitable for household and commercial burglary service. Note that installation regulations are subject to the jurisdiction of a local authority.

2.4.1 Hardware Requirements

See Figure 3–4 and Figure 3–5 (Section 3) for diagrams of a suggested installation.

1. A second MX8000 must be installed as a backup in case the primary MX8000 fails. The backup system must be able to take over within 30 seconds. (Note: This requirement does not apply to burglary-only installations.)
2. The MX8000 must be housed in a metal rack-mounting cabinet that is UL Listed for fire protective signaling use. A recommended enclosure is a listed control unit accessories system cabinet, manufactured by Atlas/Soundelier. (The WA200 series, intended for 19-inch rack mount panels, can be used.) A taller cabinet could be used to house additional units.
3. Any unused front panel rack space must be filled with blank panels so that all wiring remains enclosed.
4. The external conduit must exit through the knockouts in the cabinet or go directly through the floor.

2.4.2 Operational Requirements

1. The transmitters reporting to the MX8000 must be UL Listed DACTs (digital alarm communicator transmitters).
2. The central station must provide a minimum of 24 hours of backup power within 30 seconds of an AC power loss. The backup must either be in the form of a UL Listed UPS or electrical generator.
3. If the MX8000 is not automated, the central station operator must check for the 24-hour test signals from the communicators. (Note: This requirement does not apply to burglary-only installations.)
4. The connection between the MX8000 and the UL Listed computer should be according to the pin configuration for Com Port 1 as shown in Section 3.13, Figure 3–15 and Figure 3–16, of this manual. (Note: This port is for ancillary use only.)
5. If a computer is used, the computer and its accessories must be installed in the same room as the receiver.
6. Com Port 2 is for ancillary use only. If used, the device connected to Com Port 2 must be installed in the same room as the receiver.
7. The UL Listed printer connected to the receiver printer port must be installed in the same room as the receiver.
8. When using a MX8000–LRR line card, the transceiver connected to the MX8000–LRR P1 connector must be installed in the same rooms as the receiver.

2.4.3 Programming Requirements

In a UL Listed installation, the MX8000 receiver must be programmed according to the following procedure:

- Do NOT use the alarm output relay in UL installations.
- Each log-on code must have at least four digits.

Section 3 Installation

This section contains information necessary to install a MX8000 Digital Alarm Receiver.

IMPORTANT:
Do not connect power to the system until you have read these instructions carefully.

3.1 Quick Start

The following procedure provides a quick start outline that may be used by installers who are familiar with the installation and programming of the MX8000 receiver. This procedure encompasses the basic installation and programming steps where the unit will be using mostly default values for operation. For complete installation procedures, bypass this section and observe the procedures in the balance of this manual. To perform the quick start installation, proceed as follows:

1. Install any additional line cards into the receiver. (See section 3.7 for additional information.)
2. Power up the receiver by plugging it into an AC outlet. (See section 3.11 for additional information.)
3. Log onto the receiver as the installer. (See section 4.4 for additional information.)
4. Set the receiver time and date. (See section 4.6.6 for additional information.)
5. Enter the program mode by selecting it from the main menu.
6. Select the operation mode for the receiver. (See section 5.3.1 for additional information.)
7. Configure communications and printer ports. (See section 5.3.3 for additional information.)
8. Define device (line card) types and options. (See section 5.4 for additional information.)
9. Select the automation protocol to be used. (See section 5.3.3.5 for additional information.)
10. Exit the program mode and log off the receiver.

3.2 Environmental specifications

- Temperature range is 32° to 120° F.
- Indoor use only.
- 85 percent non-condensing humidity.
- Non-corrosive environment.

3.3 Electrical Specifications

Line Voltage:		120VAC, 60Hz, 100VA 240VAC, 50Hz, 100VA	
Fuse:		2.5A Slow Blow	
Current Draw: (VFD brightness at 50%, all lines on the line cards in trouble [LEDs On], Auxiliary Relay Off)	MX8000	230mA (with no Line Cards)	
	MX8000-LC1	40mA	
	MX8000-LC3	35mA	
	MX8000-LRR	75mA	
Backup Battery Connection: A 12 VDC battery does not provide standby time required by UL and NFPA standards. A UPS (listed for Protective Signaling Use) must be utilized when standby power is required. See 5.3.4 for details on backup battery configuration. Refer to Section 9 of UL827 for power requirements.	Input	10.2 to 14.0 VDC 3 Amp Max.	
	Output	13.65 VDC	1.7 Amp charging current
Auxiliary Relay: The relay field connection must be to a power limited source.		2.5 Amp @ 48VDC	Resistive Power Limited
		2.5 Amp @ 48VAC	Resistive Power Limited

3.4 Overview

The MX8000 is assembled at the factory. One MX8000-LC3 tri-line card is shipped with the MX8000 receiver. Follow the procedures described in Section 3.7 to install additional line cards.

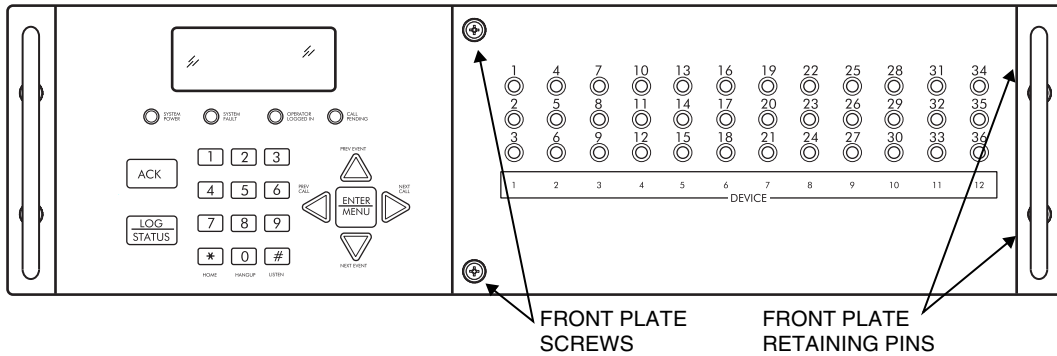

Figure 3-1: MX8000 Front View

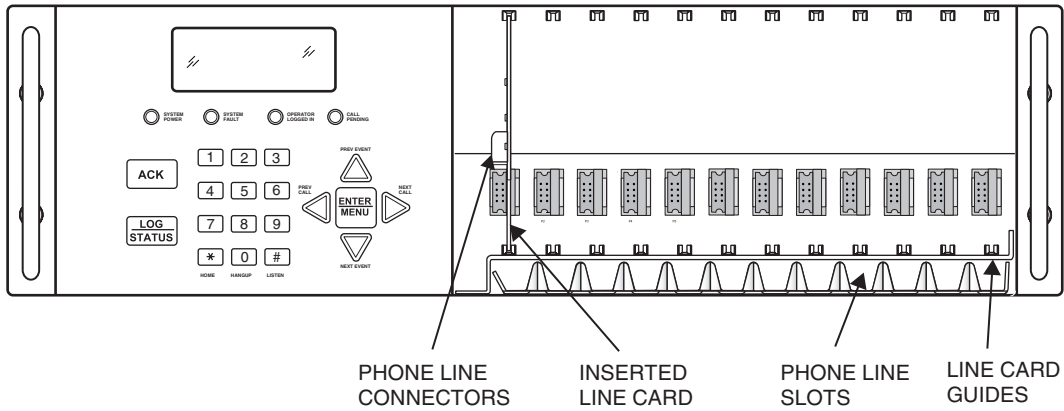

Figure 3-2: MX8000 Front View Without Front Plate Attached

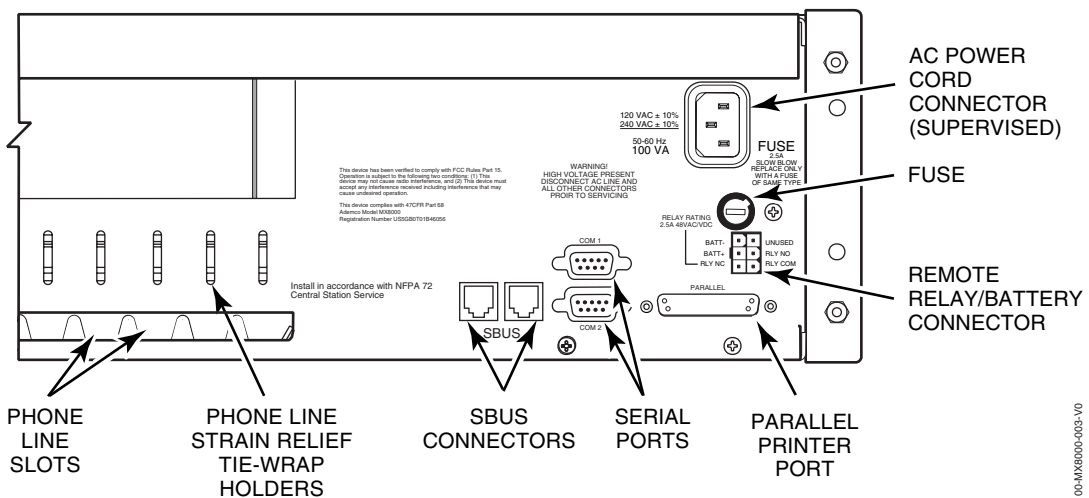

Figure 3-3: MX8000 Rear View

3.5 Rack Mounting

This diagram shows how to mount the MX8000 in a UL Listed rack enclosure.

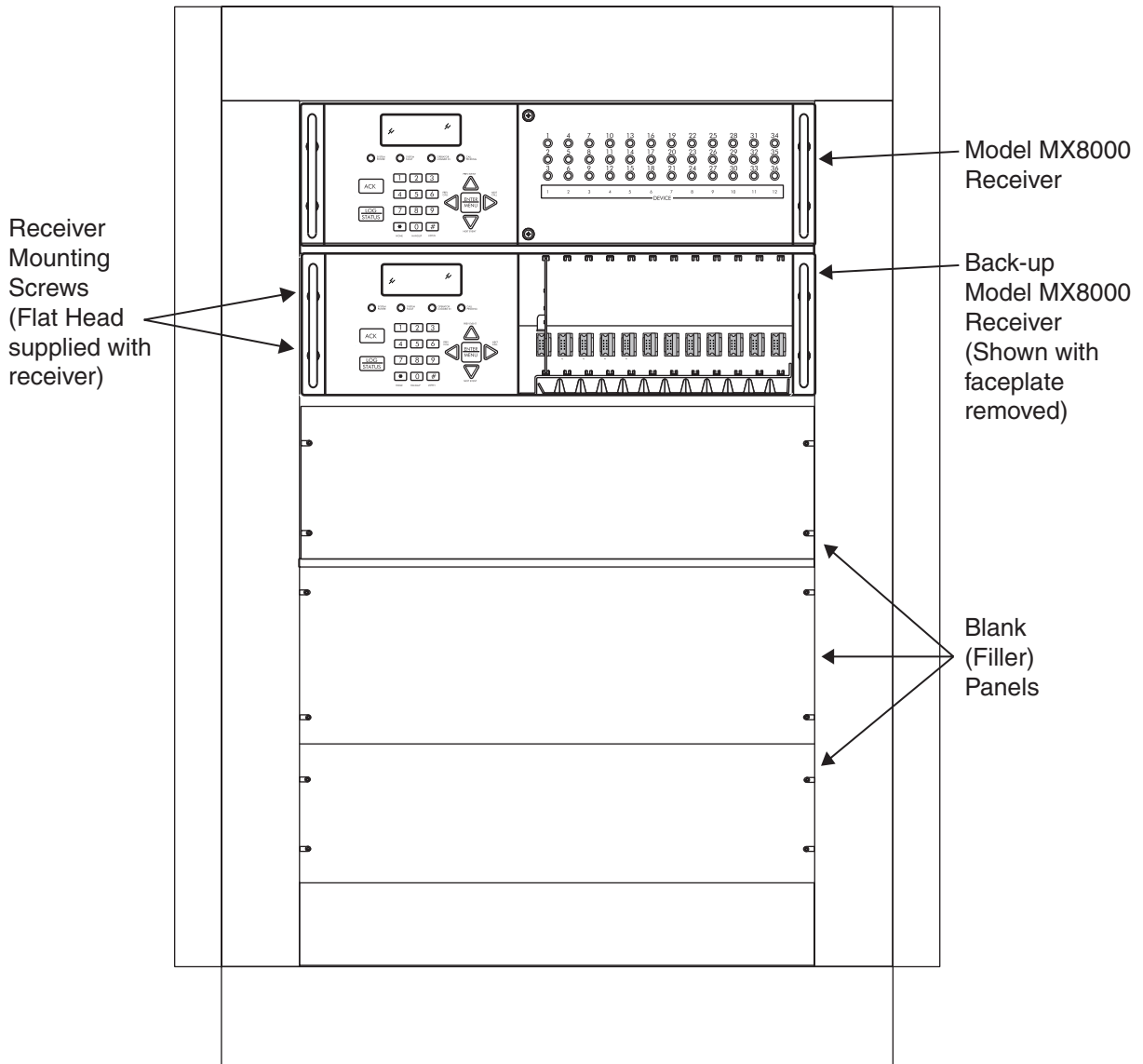

Figure 3–4: Rack Mount Enclosure, Front View

Note: All wiring that exits cabinet must be in electrical conduit.

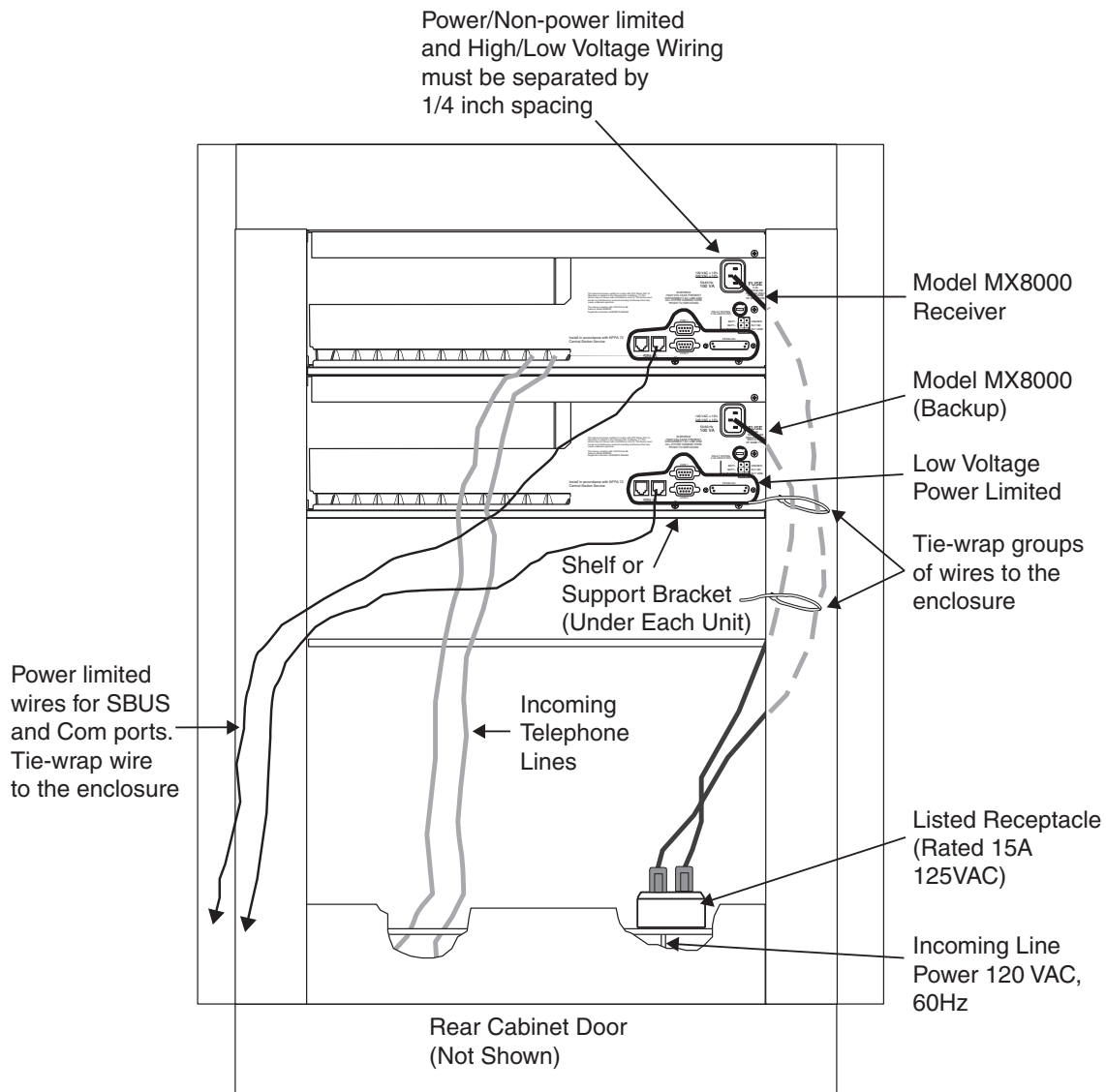

Figure 3-5: Rack Mount Enclosure, Rear View

Note: All wiring that exits cabinet must be in electrical conduit.

3.6 Hot Swapping of Line Cards

The MX8000 is designed to allow hot swapping (swapping with power applied) line cards in the event of a line card failure. To hot swap a line card, observe the following procedure:

Notes:

- When hot swapping line cards, the replacement card must be the same type of card as the card being removed (i.e., MX8000-LC3 with MX8000-LC3).
 - When hot swapping line cards, only remove and replace one card at a time to avoid hanging up the system.
1. While holding the front plate, unscrew the two front plate retaining screws located on the front of the panel. (See Figure 3-1 for front plate retaining screw locations.)
 2. Open the MX8000's front panel by pulling the left side of the front plate slightly forward and then to the left to remove it from the receiver.
 3. Locate the Line Card that you wish to remove.
 4. Unplug the telephone line(s). (See Figure 3-6 and Figure 3-7.)

5. From the front side of the receiver pull the line card straight back. This will pull the card free from the connector. A message similar to the following will be printed on the MX8000 printer.

```
05/21/2004 11:42:53AM
System Receiver #: 1 Reference #: 772
Expander Trouble #7
```
6. When the card is free, slide it carefully out of the receiver.
7. Carefully slide the replacement card into its guides (both top and bottom) until it fits into its connector at the back of the receiver. Gently push the card as far into the connector as you can. The card is now in place.
8. Connect telephone line(s) or the line to the transceiver if installing a MX8000-LRR Radio Line Card. (See Section 3.9 for telephone line installation.) In approximately 60-90 seconds the new line card will be restored into the system with the line card LEDs working normally and a message similar to the following will be printed on the MX8000 printer.

```
05/21/2004 11:43:54AM
System Receiver #: 1 Reference #: 774
Expander Trouble Restore #7
```
9. If you need to hot swap and additional card, repeat steps 1 through 9.
10. Close the MX8000's front panel and tighten the front plate retaining screws to hold the front plate in place.

Note: If a lock up occurs, reboot the system by removing primary power and reapplying it to clear the condition.

3.7 Line Card Installation

Caution:

To reduce the risk of electrical shock and damage to the receiver, follow these steps in the order they are listed here.

1. While holding the front plate, unscrew the two front plate retaining screws located on the front of the panel. (See Figure 3–1 for front plate retaining screw locations.)
2. Open the MX8000's front panel by pulling the left side of the front plate slightly forward and then to the left to remove it from the receiver.
3. When the front panel is removed, you will see that there are 12 slots for line cards. The receiver recognizes each slot by number 1 through 12 (slot one is closest to the keypad and display). It is not necessary to put line cards in numbered order because the receiver continually polls each slot to see if existing line cards are functioning and if it is still in its slot. The receiver also looks to see if a new line card has been added. Figure 3–6 shows where each line card should be placed.

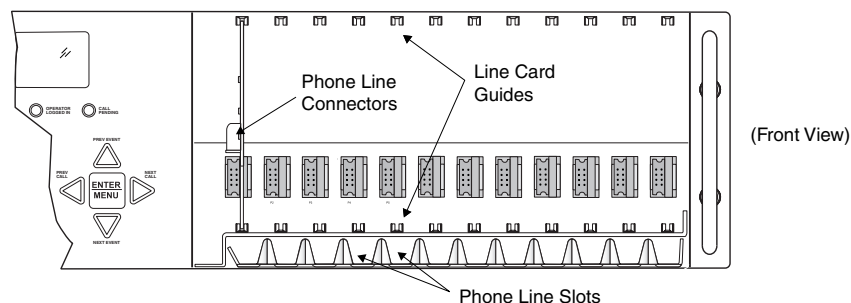

Figure 3–6: Line Card Locations

4. Position the line card as shown in Figure 3–7.

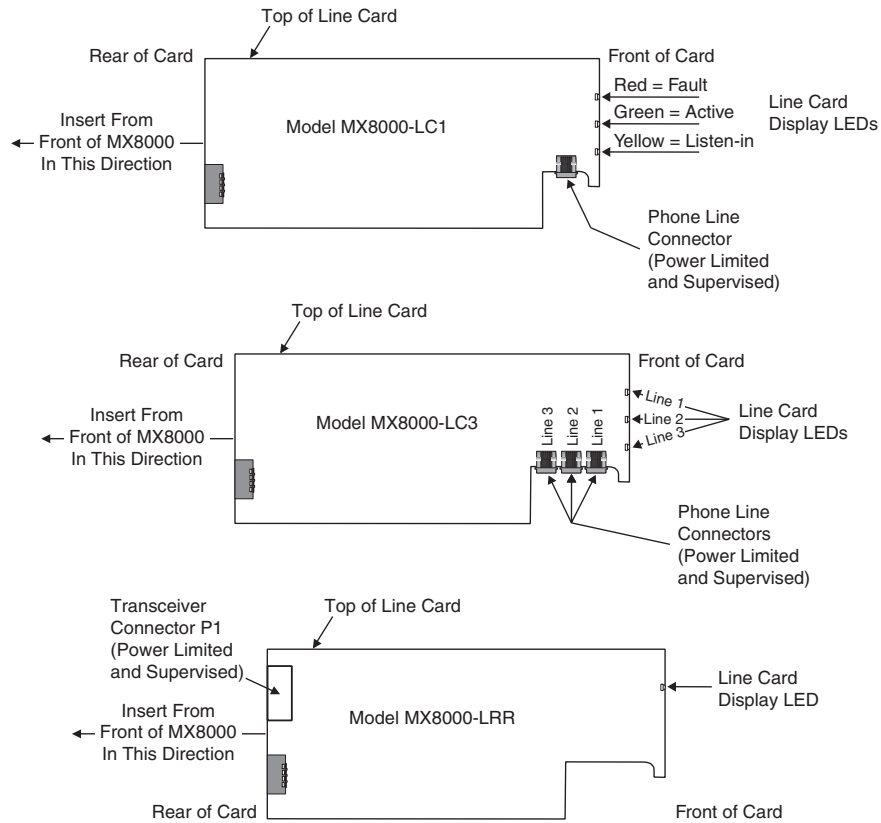

Figure 3-7: Line Card Position and Components

5. Carefully slide the card into its guides (both top and bottom) until it fits into its connector at the back of the receiver. Gently push the card as far into the connector as you can. The card is now in place.

Notes:

- If installing an MX8000-LRR Radio Line Card and you will be using the VPN feature with ADEMCO 8000 automation protocol, the card must be installed in slot 12.
- If installing an MX8000-LRR Radio Line Card and you will be using the VPN feature with 685 or CAPS automation protocol *WITHOUT* using Virtual Receiver / Line numbers, the card must be installed in slot 3 (see page 1-6).
- If installing an MX8000-LRR Radio Line Card and you will be using the VPN feature with 685 or CAPS automation protocol *WITH* Virtual Receiver / Line numbers, assign the card as line 8.
- When outputting to an automation computer and using the MX8000-LRR card, only the 685, CAPS, or ADEMCO 8000 automation protocol may be used.

6. Connect telephone line(s) or the line to the transceiver if installing a MX8000-LRR Radio Line Card. (See Section 3.9 for telephone line installation.)

Notes:

- Use the tie wrap (provided with each line card) on the tie wrap holder to add strain relief to the telephone lines. See Figure 3-3.
- When using a MX8000-LRR line card in UL installations, the transceiver connected to the MX8000-LRR P1 connector must be installed in the same room as the receiver.
- When using a MX8000-LRR line card in FM installations, the 7810 Radio Transceiver connection to the MX8000-LRR must be within 20 ft. (6m) of the MX8000 and in the same room as the MX8000.

7. Restart the receiver in accordance with the procedures provided in Section 4.6.7.
8. Close the MX8000's front panel and tighten the front plate retaining screws to hold the front plate in place. If you are simply replacing a line card with another card of the same type and are using the same format settings, your installation is now complete. If not continue to the next step.
9. Enter programming mode to select the appropriate handshake configuration. (Go to Section 5.4 for programming procedure.)

3.8 Removing Line Cards

If you need to remove a card:

1. If you will not be replacing the line card or will be replacing it with a different type of line card (for example, replacing an LC1 with an LC3), enter the programming mode to clear the line card from the system. (See Section 5.4 for programming procedure.)
2. While holding the front plate, unscrew the two front plate retaining screws located on the front of the panel. (See Figure 3–1 for front plate retaining screw locations.)
3. Open the MX8000's front panel by pulling the left side of the front plate slightly forward and then to the left to remove it from the receiver.
4. With the front panel removed, you will see that there are 12 slots for line cards.
5. Locate the Line Card that you wish to remove.
6. Unplug the telephone line(s). (See Figure 3–6 and Figure 3–7.)
7. From the front side of the receiver pull the line card straight back. This will pull the card free from the connector.
8. When the card is free, slide it carefully out of the receiver.
Note: If replacing a line card with a new one see Section 3.7 to install the new line card.
9. Restart the receiver in accordance with the procedures provided in Section 4.6.7.
10. Close the MX8000's front panel and tighten the front plate retaining screws to hold the front plate in place.

3.9 Telephone Line Connection

See Figure 3–6 for the location of the phone line inputs. Connections to the MX8000 phone jacks are made with a standard 7-foot phone cord.

Use the following procedure to connect phone lines to the MX8000-LC1 or MX8000-LC3 line cards:

1. While holding the front plate, unscrew the two front plate retaining screws located on the front of the panel. (See Figure 3–1 for front plate retaining screws locations.)
2. Open the MX8000's front panel by pulling the left side of the front plate slightly forward and then to the left to remove it from the receiver.
3. From the back side of the receiver insert the telephone line(s) through the corresponding slot for the desired line card. (See Figure 3–6 and Figure 3–7 for phone line slot locations.)
4. Gently push them all the way through to the front side of the receiver.
5. Plug the RJ-11 phone connector(s) into the connector(s) on the line card. (See Figure 3–6 and Figure 3–7.)
Note: Use the tie wrap (provided with each line card) on the tie wrap holder to add strain relief to the telephone lines. See Figure 3–3.
6. Replace the front panel of the MX8000 receiver by tightening the front plate retaining screws. (See Figure 3–1 for front plate retaining screws locations.)

3.10 Parallel Printer Connection

The MX8000 Receiver connects to a UL Fire Protection Services approved dot matrix parallel printer such as the Okidata Microline 320 for UL applications. To connect the printer to the MX8000 receiver follow these steps:

- Notes:**
- For UL installations, the printer must be installed in the same room as the MX8000.
 - For FM installations, the printer or any automation system connection must be within 20 ft. (6m) of the MX8000 and in the same room as the MX8000. The Okidata Microline 320 is the only FM approved printer for use with the MX8000.

1. Connect the standard parallel printer cable to the parallel printer port on the back of the MX8000 receiver. (See Figure 3–8.)
2. Connect the other end to the printer's parallel port.

Note: Make sure that printer power is turned off.

3. Turn the printer power “on”.

NOTE: FOR UL APPLICATIONS, A STANDBY PRINTER MUST BE AVAILABLE TO BE PUT INTO OPERATION WITHIN 30 SECONDS. ONE STANDBY PRINTER MUST BE AVAILABLE FOR EVERY 5 PRINTERS.

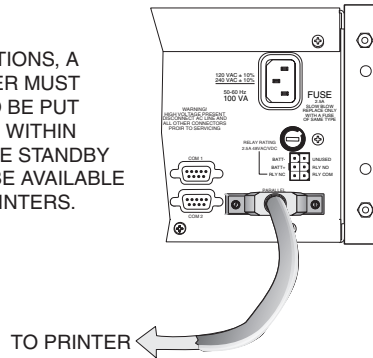

Figure 3–8: Parallel Printer Cable Connection to MX8000

3.10.1 Printer Cable Pin-Outs

25 pin printer cables are standard items at most electronic stores; however, if you create your own cable, use the pin description in Table 3–1.

Table 3–1: External Printer Cable Pin Description

MX8000 Pin #	Signal	Direction	Description
1	Data Strobe (Low)	Out	A low strobe pulse to read data into the printer. The pulse width is greater than 0.5 microseconds.
2	Data Bit 1	Out	These signals represent information of the first to eighth bits of parallel data. Each signal is at high level when the data is logic 1 and low when it is logic 0.
3	Data Bit 2	Out	
4	Data Bit 3	Out	
5	Data Bit 4	Out	
6	Data Bit 5	Out	
7	Data Bit 6	Out	
8	Data Bit 7	Out	
9	Data Bit 8	Out	
10	/AckNlg	In	A low pulse from the printer signals the control that the printer is ready for additional data.
11	Busy	In	A high level indicates that the printer is busy.
12	Paper Empty	In	A high level indicates that the printer is out of paper.
13	Select	In	A low level indicates the printer is offline or in an error condition.
14	Not used	-	-
15	Not used	-	-
16	Logic ground	-	Logic ground for printer
17	Not used	-	-
18 to 25	Logic Ground	-	Ground return for data lines.

Figure 3–9 shows the wiring sequence of this connector.

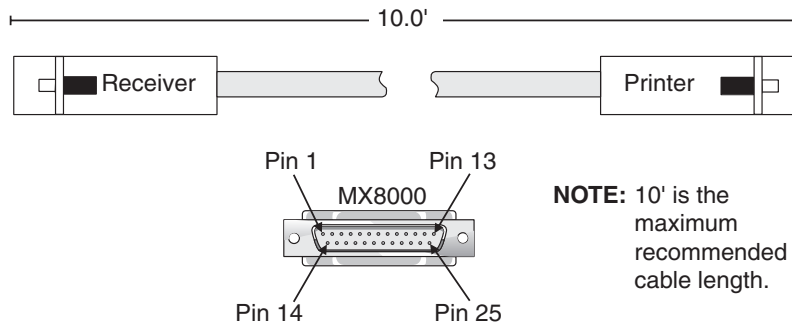

Figure 3–9: Wiring Sequence For Parallel Printer Port Interface

3.10.2 Com Ports 1 and 2

Com Ports 1 and 2 are serial communication ports that (through a null modem cable) can be used to communicate to other serial communication devices. Com Port 1 is the only serial communications port that can be used with the automation computer (see Section 3.13). A standard null modem cable can be used to connect Com Port 1 or 2 to another serial device such as a printer or a PC. Figure 3–15 and Figure 3–16 show the pin-outs for a null modem cable. See Section 5.3.2.8 to configure the Com Port 1 and Com Port 2.

Note: Com Port 1 and 2 are for ancillary use only. For UL applications, device(s) connected to either of these ports must be installed in the same room as the receiver.

3.10.3 Remote Alert Output

1. Plug the Battery/Relay wiring harness onto the connector on the back of the MX8000 receiver. (See Figure 3–10.)

Note: The remote alert output is a form C relay with a normally open or a normally closed wire.

2. Connect the white wire to common.

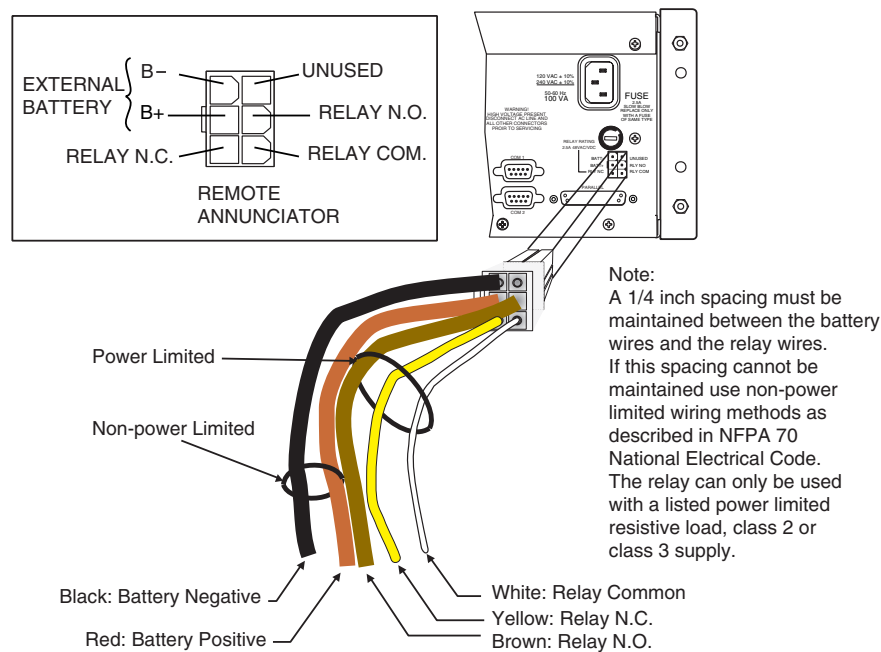

Figure 3–10: MX8000 Remote Alert Output/Backup Battery Connection

3. Use the Yellow wire for a normally closed circuit
Or
Use the Brown wire for a normally open circuit.

3.11 AC Power Cord Connection

1. Connect the appropriate end of the power cord into its receptacle on the back of the MX8000.
2. Plug the three-pronged end of the power cord into a 120 VAC 60 Hz outlet (three-prong type only). The outlet should be unswitched, so that power remains on 24 hours a day. The outlet must also be earth grounded. Follow the directions in Section 3.11.2 if you need to measure for proper earth grounding.

3.11.1 Switching to a 240 VAC Power Supply

1. Remove the front plate by unscrewing the front plate retaining screws. (See Figure 3–1 for locations of front plate retaining screws.)
2. Disconnect AC power cable.

3. Disconnect the backup battery. (See Figure 3–14.)
4. On the back of the receiver remove the four screws that hold the CPU, PS, User Interface Assembly to the chassis. (See Figure 3–11 for screw locations.)

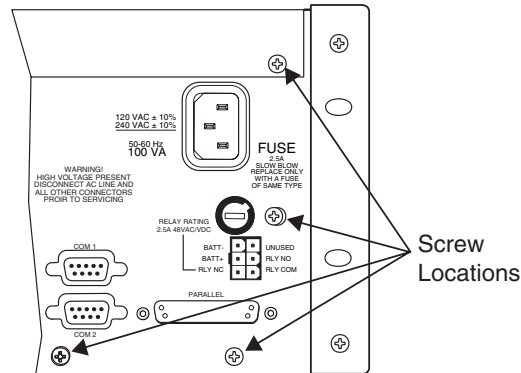

Figure 3–11: CPU, PS, User Interface Assembly Retaining Screw Locations

5. From the front of the receiver, pull the CPU, PS, User Interface Assembly out of the receiver chassis
6. Switch the power supply select switch to the up position. (See Figure 3–12.)
7. Slide the CPU, PS, User Interface Assembly back into the receiver chassis.
8. On the back of the receiver replace the four screws that hold the CPU, PS, User Interface Assembly in place. (See Figure 3–11.)

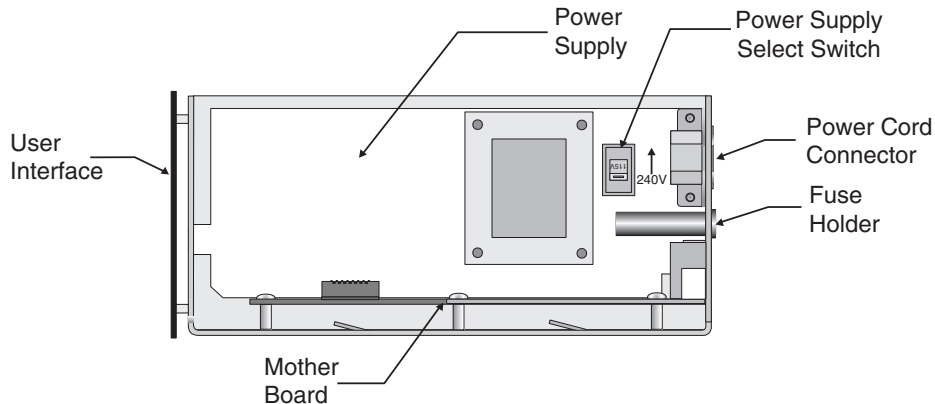

Figure 3–12: Side View of CPU, PS, User Interface Assembly

9. Reconnect the AC power cable.
10. Reconnect the back-up battery. (See Figure 3–14.)
11. Replace the front plate by screwing in the front plate retaining screws. (See Figure 3–1.)

3.11.2 How to Verify Earth Ground

To verify earth ground at the AC outlet the MX8000 receiver is powered from, use the following steps:

1. Measure the AC voltage between the center ground post and each side of the outlet (see A & B in Figure 3–13). You should read approximately 120 VAC at measurement point B and nominal VAC at measurement point A.
2. Measure the voltage between the two slotted holes. It should be equal to the voltage reading at measurement point B. (See Figure 3–13.)

If these voltages are not equal, the outlet does not have a proper earth ground.

3. Ground the outlet by running a wire (18 gauge or higher) to a good earth ground.

The wire should be of equal or greater diameter to the wires used to feed the outlet. It may be necessary to have a licensed electrician ground the outlet.

3.13 Automation Computer Connection

An automation computer can be connected to Com Port 1 on the MX8000 receiver. Com Port 1 is a 9-pin DTE port. Refer to Section 8 for details on automation communication protocols. The diagrams below describe some of the cable options.

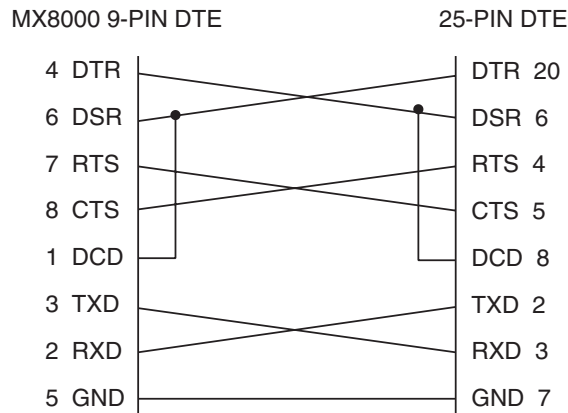

Figure 3–15: 25-Pin Null Modem Cable Connection

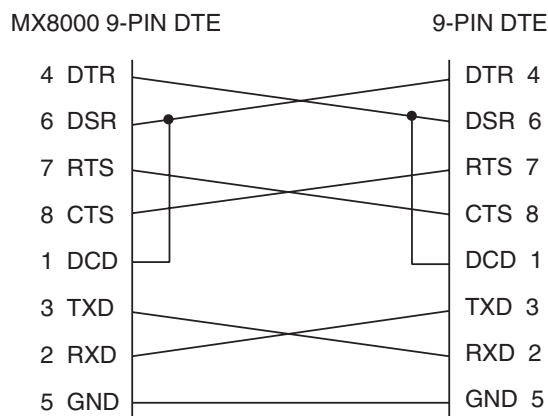

Figure 3–16: 9-Pin Null Modem Cable Connection

3.13.1 Computer Port Baud Rate Selection

The computer port baud rate is selectable from 110 to 38400 (See Section 5 – *Programming*)

3.14 Master/Slave Receiver Linking

The SBUS connector on the receiver can be used to link up to 3 receivers outputting to one automation computer and/or printer depending on the Master/Slave configuration. When this configuration is used, 1 receiver is set up as a master and remaining receivers are set up as slaves. The linking feature can decrease the number of serial ports required on the automation computer and/or the quantity of dot matrix printers used for automation backup. When using this feature, if the automation computer goes down, the information normally sent to the automation computer is output to the automation backup printer preceded by the receiver number that the information is coming from.

3.14.1 Receiver Linking Cabling Connections

To use master/slave receiver linking, connect the receivers as shown in Figure 3–17 for linking to a printer or to both a printer and automation computer. If linking to only one slave receiver, simply omit the cable

that is not required. The cabling used is standard 4-wire RJ-11 cables (see Figure 3–18) for the interconnection of the receivers, a standard 25 pin printer cable as described in Section 3.10 and 3.10.1, and a DTE cable for the automation computer connection as described in Section 3.13. See Section 3.14.2 for Master/Slave Linking Programming Procedures.

Notes:

- For FM installations, the printer or any automation system connection must be within 20 ft. (6m) of the MX8000 and in the same room as the MX8000. The Okidata Microline 320 is the only FM approved printer for use with the MX8000.
- If necessary (in non-FM installations), a serial printer can be used as the automation backup printer. In that situation, connect the serial cable from the COM2 port of the Master Receiver to the printer and omit the parallel printer connection.

3.14.2 Master/Slave Linking Programming

The receivers may be programmed for master/slave linking to report to an automation computer and/or printer. The receivers must be programmed for master/slave linking on power-up when this feature is used. To perform linking programming, see 3.14.2.1 Master Printer/Slave Printer Linking Programming or 3.14.2.2 Master Automation/Slave Automation Linking Programming below.

Note: If it is desired to use linking for both the automation computer and printer, perform the procedures in 3.14.2.2 Master Automation/Slave Automation Linking Programming below. Printer linking will automatically be in effect when these procedures are performed.

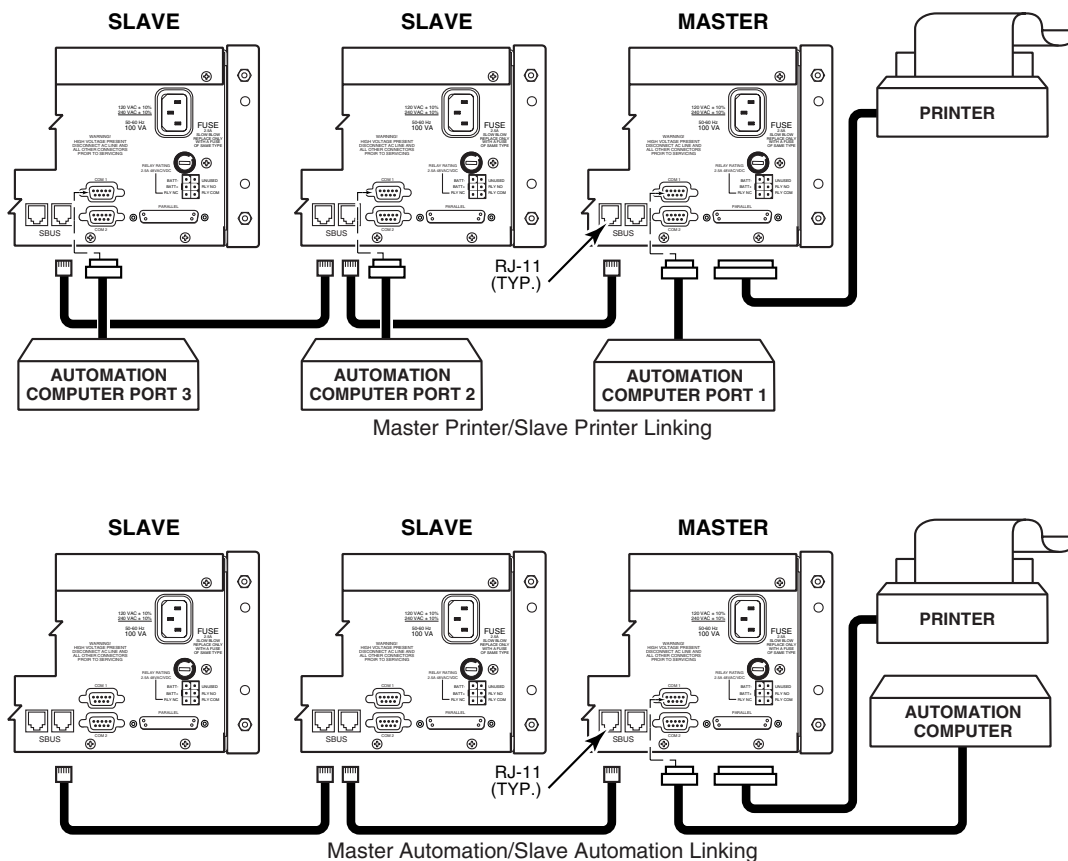

NOTE
LIMIT TO ONE MASTER AND TWO SLAVES.

Figure 3–17: MX8000 Master/Slave Receiver Linking Cabling Connections

09-1008000-004-V0

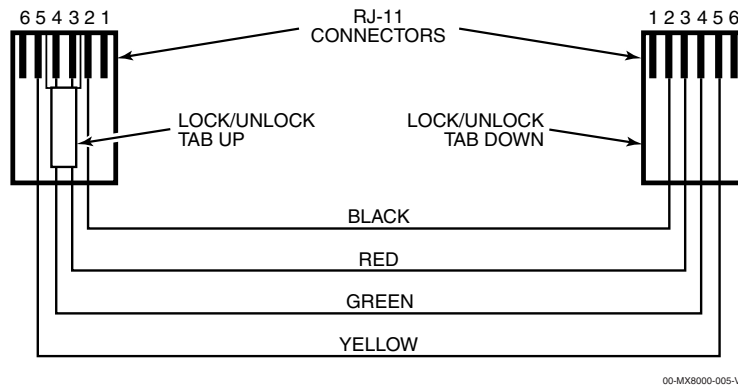

Figure 3–18: SBUS Receiver Linking Cable

3.14.2.1 Master Printer/Slave Printer Linking Programming

To perform MasterPrn/SlavePrn Linking Programming, follow these steps:

1. Verify that all SBUS connections have been made as described in Section 3.14.1 and shown in Figure 3–17.
2. Program the Master (MstrPrn) Receiver as follows:
 - a. Power up the Master Receiver and allow the Line Cards to be initialized.
 - b. From the “Installer/Program Menu/General Options” display, select “1 Operation Mode” and configure for “Automatic.”
 - c. From the “3 Communications” display, select “1 Port Functions” and configure COM1 for “Automation” and parallel port for “Auto Bkp Prn.”
Note: If a serial printer is being used as a automation backup printer, configure COM2 as the “Auto Bkp Prn” instead of the parallel port.
 - d. From “4 System Options” select “MstrPrn” and set appropriate “Rcvr ID.”
 - e. From “6 Slave List” enter a unique Slave number for each slave receiver.
 - f. Exit the programming mode and cycle power on the Master Receiver for the new settings to take effect.
3. Program the Slave (SlvPrn) Receiver as follows:
 - a. Power up the Slave Receiver and allow the Line Cards to be initialized.
 - b. From the “Installer/Program Menu/General Options” display, select “1 Operation Mode” and configure for “Automatic.”
 - c. From the “3 Communications” display, select “1 Port Functions” and configure COM1 for “Automation.”
 - d. From “4 System Options” select verify “SlvPrn” setting and set appropriate “Rcvr ID.” matching the number programmed in the Master Receiver.
 - e. Exit the programming mode.
 - f. Repeat a. through e. on the second Slave Receiver, if being used.

3.14.2.2 Master Automation/Slave Automation Linking Programming

To perform MasterAuto/SlaveAuto Linking Programming, follow these steps:

1. Program the Master (MstrAuto) Receiver as follows:
 - a. Power up the Master Receiver and allow the Line Cards to be initialized.
 - b. From the “Installer/Program Menu/General Options” display, select “1 Operation Mode” and configure for “Automatic.”

- c. From the “3 Communications” display, select “1 Port Functions” and configure COM1 for “Automation” and parallel port for “Auto Bkp Prn.”
Note: If a serial printer is being used as a automation backup printer, congigure COM2 as the “Auto Bkp Prn” instead of the parallel port.
 - d. From “4 System Options” select “MstrAuto” and set appropriate “Rcvr ID.”
 - e. From “6 Slave List” enter a unique Slave number for each slave receiver.
 - f. Exit the programming mode and cycle power on the Master Receiver for the new settings to take effect.
2. Program the Slave (SlvAuto) Receiver as follows:
 - a. Power up the Slave Receiver and allow the Line Cards to be initialized.
 - b. From the “Installer/Program Menu/General Options” display, select “1 Operation Mode” and configure for “Automatic.”
 - c. From “4 System Options” select verify “SlvAuto” setting and set appropriate “Rcvr ID.” matching the number programmed in the Master Receiver.
 - d. Exit the programming mode.
 - e. Repeat a. through d. on the second Slave Receiver, if being used.
 3. Using 4-pin RJ-11 cables, connect a cable from the Master Receiver to the first Slave Receiver and then connect a second cable from the first Slave Receiver to the second Slave Receiver.

Section 4 Operation

This section covers information on how to operate the MX8000 Receiver.

4.1 Touchpad Function Buttons

The front panel of the MX8000 is made up of; a touchpad, containing numbers, arrows and buttons; a VFD display; and an array of LED indicators. (See Figure 4–1.)

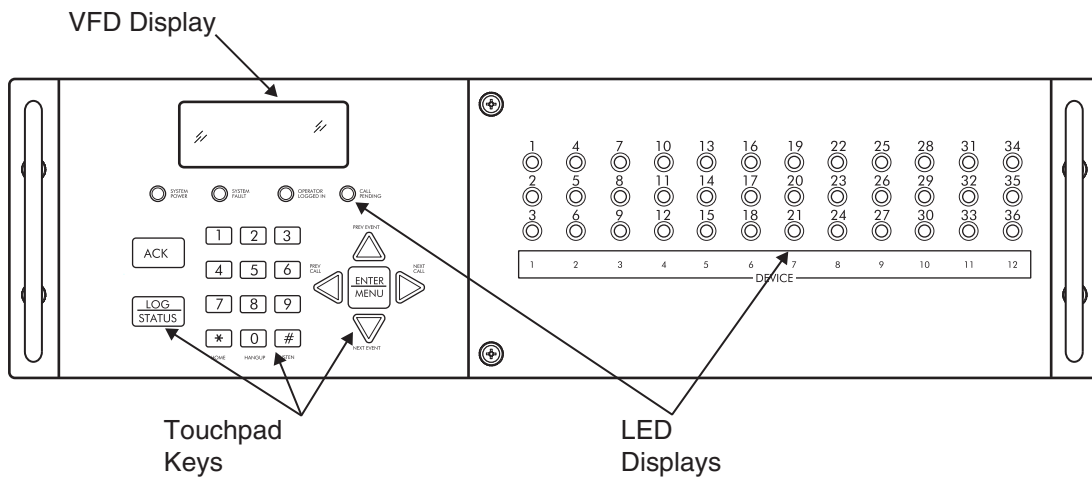

Figure 4–1: MX8000 Front Panel

The touchpad on the MX8000 Receiver is used in all operating modes (normal and programming mode).

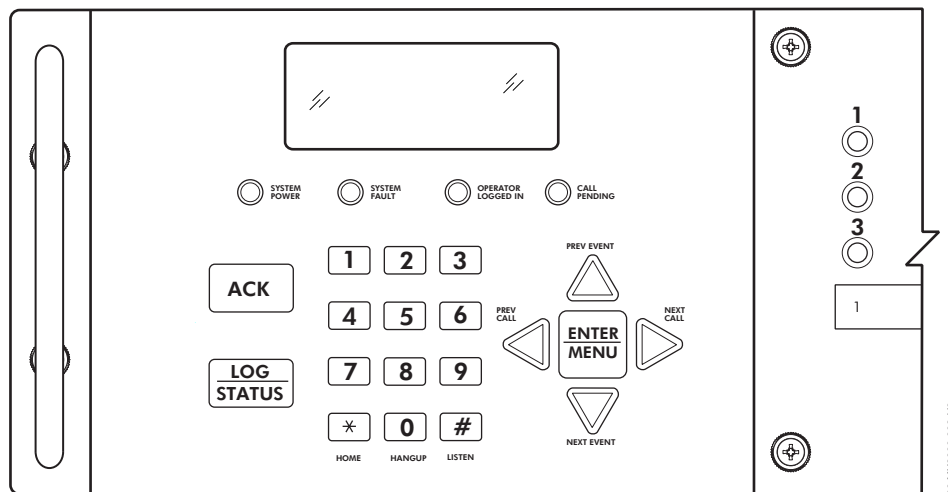



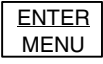

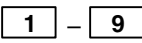





Figure 4–2: Touchpad Layout

Table 4–1 displays each individual touchpad key and describes its function in each operating mode.

Table 4–1: Touchpad Buttons Description

Key	Name	Operating Mode	
		Normal	Programming
	Up Arrow	Display previous item in the Call History or System History.	Go back to previous choice or character.
	Down Arrow	Display next item in the Call History or System History.	Move to next choice or character.
	Left Arrow	Display previous item in the Call History. Exits System History.	Exit the current menu. Move to previous programming field.
	Right Arrow	Display next item in the Call History. Not used in System History	Select menu item indicated by equal sign (see Figure 4–5). Move to next programming field.
	Enter/Menu Button	Bring up Main Menu.	Select menu item indicated by equal sign (see Figure 4–5). Enter chosen parameter.
	Acknowledge Button	Manually Acknowledge a call or event. (Used only if receiver is in manual mode.)	Used in log mode to acknowledge and silence system troubles.
	Log Button	Pressed to log on or off the system. Pressed to view system status messages.	N/A
	Digit Keys	Used to enter numeric inputs.	Numeric input, option selection.
HOME 	Star or Home Key	Will return display to the oldest unacknowledged event.	Enters a * Character when programming in an “Edit” field. See Table 5–1 for <i>Types of Programming Fields</i> , descriptions.
HANGUP 	0 or Hangup key	In manual mode the 0/ hangup key is used to hangup line card when the listen feature was activated, or to end a runaway call from a panel.	Used to enter numeric inputs.
LISTEN 	Pound Key or Listen Key	In manual mode this key is used to initiate the listen in feature.	Enters a # Character when programming in an “Edit” field. See Table 5–1 for <i>Types of Programming Fields</i> , descriptions.

4.2 Displays

This section describes the two types of displays that the MX8000 receiver uses.

4.2.1 LED Displays

Table 4–2: LED Description

LED		Meaning		
		On	Off	Flashing
Touchpad LEDs	System Power	System power is on.	No AC or DC power to the Receiver	No AC power and the system is operating on the backup battery.
	System Fault	A fault condition exists that has been acknowledged but not cleared.	The system is operating normally.	A fault condition exists that has not been acknowledged.
	Operator Logged In	An operator is logged on.	No operator is logged on.	
	Call Pending	The acknowledge key was pressed at least once, but not all the events in a call were acknowledged.	No calls pending or all calls have been acknowledged.	Calls pending.
Line Port LED (MX8000-LC3 and MX8000-LRR)	Off		The line card is operating normally.	
	Red			Slow Flash – Uninitialized. Fast Flash – Trouble (Specifics available on VFD).
	Green	Off Hook		Ring Detection – Flash follows ring. Listen-in – 1 sec. on, 1 sec off.
Line Port LEDs (MX8000-LC1)	Red (Fault)	N/A	The line card is operating normally.	Slow Flash – Uninitialized. Fast Flash – Trouble (Specifics available on VFD).
	Green (Active)	Off Hook	No activity.	Ring Detection – Flash follows ring.
	Yellow (Listen-in)	Comes on when operator acknowledges the listen-in call.	No listen-in occurring.	N/A

4.2.2 VFD Status Display

The status display is a 4-line 20 character (each line) backlit VFD that shows the various alarm and function messages. It functions in all modes of operation (normal and programming mode). As the MX8000 acknowledges calls and messages, it updates the calls on the VFD and silences the alert tone.

```

MX8000 Receiver
  Ademco
Man: Active
01/01/01 08:32:44

```

Figure 4–3: VFD Display

4.2.2.1 VFD Abbreviations

Many of the words used on the VFD are abbreviated to accommodate 20 characters per line. Table 4–3 compares the event that is reported to how it is output to the VFD and printer.

Table 4-3: VFD and Printer Abbreviations

Event	VFD	Printer
Alarm	Alrm	Alarm
Trouble	Trbl	Trouble
Restore	Rstr	Restore
Supervisory	Sprv	Superv
Opening	Open	Opening
Closing	Clos	Close
Remote	Rmot	Remote
Disable	Dsbl	Disable
Bypass	Byps	Bypass
Unbypass	Ubyb	Unbypass
Test	Test	Test
Listen-in	Lstn	Listen
System	Sytm	System
Access	Accs	Access
Report	Rprt	Report
Cancel	Cncl	Cancel
Zone Number	Z#	Zone
Door Number	D#	Door
User Number	Us#	User
Area Number	A#	Area

4.3 Initial System Power Up

Apply power to the MX8000 by plugging in the AC power cable. (See Figure 3-3.) When the MX8000 powers up, the display will go through the routine shown in Figure 4-4.

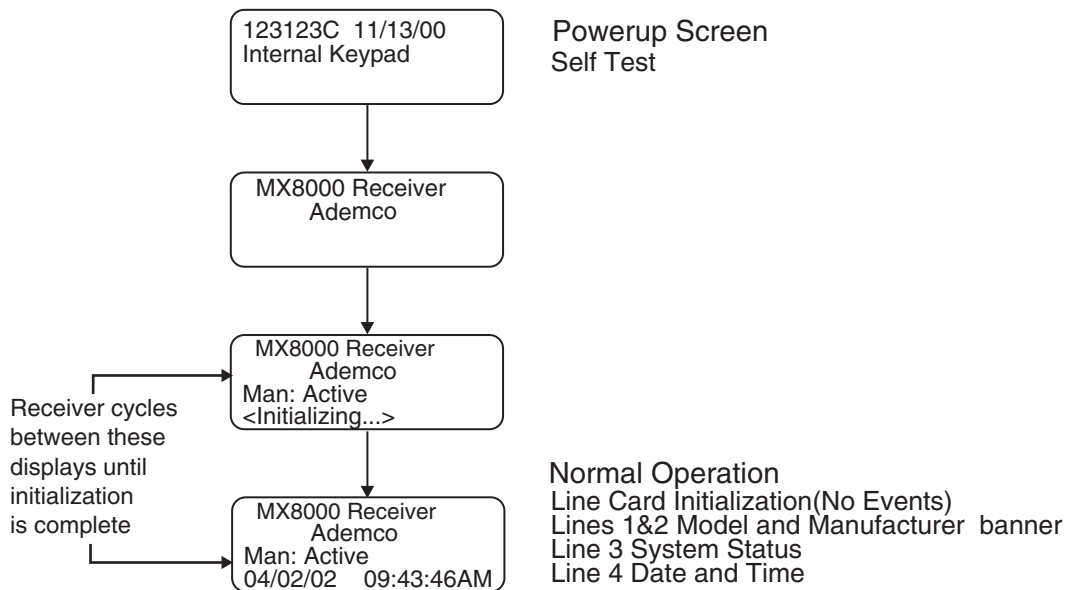

Figure 4-4: Power-up Routine

The system defaults in the manual operation. To select automatic operation see Section 5.3.1.1.

Note: Any time the power is removed from the receiver (line and battery), the time and date will have to be reprogrammed on power-up.

4.4 Log On / Log Off

Persons operating the MX8000 must log on and off the system. This is a way of keeping track of who is operating the system at any given time. You can program a total of 40 codes. Each code will be assigned to one of two user profiles (Installer profile or Operator profile). (See Section 4.4.3 for default user codes.)

4.4.1 Installer Profile

The Installer profile will have access to all options on the main menu (see Table 4–4 for “Main Menu” options).

4.4.2 Operator Profile

The Operator profile has access to fewer main menu options than the Installer profile (see Table 4–4). These options allow the operator to perform basic operation of the MX8000. Both profiles can acknowledge all calls and events.

Table 4–4: Main Menu Option Items by Profile

Installer Profile	Operator Profile	Menu Options
✓	✓	Call History
✓	✓	System History
✓	✓	System Info
✓	✓	Set Time & Date
✓	✓	System Restart
✓		Printer Menu
✓		Program Menu
✓		Diagnostics

Note: See Section 4.6 for detailed information on the main menu options.

You must have at least one Installer Profile Code programmed in the system at all times.

4.4.3 Default User Codes

At initial power up, the system provides two default user codes. User code 1 defaults with an Installer profile and user code 2 defaults with an Operator profile. Table 4–5 shows the default codes and their profiles.

Table 4–5: Default User Codes

User Number	Default Code (PIN)	Default Profile
*1	8000	Installer
2	1111	Operator

**Note:* User code 1 can be changed but not deleted. User code 1’s profile will always remain as “installer”.

4.4.4 How to log on the system.

Follows these steps to properly log on to the system:

1. Press the

LOG STATUS

 button.

The VFD will display

Enter Log In Code: []

2. Enter your PIN code. (See Table 4–5 for default codes.)

Note: This screen will time out after 15 seconds.

3. Press the button.

If the correct PIN is entered the VFD will display

Logged in as
Installer # XX
User Name.

The “Operator Logged In” LED will also turn on.

If an invalid code is entered the VFD will display .

Note: If the previous user has not logged off, a new user can still log on by entering a PIN code. This will automatically log off the previous user and log in the new user.

4.4.5 How to log off the system.

Follows these steps to properly log off the system:

1. Press the button.

The VFD will display

#nn User Name
Log Out
[]

Note: This screen will time out after 15 seconds.

2. Enter your PIN code. (See Table 4–5 for default codes.)
3. Press the button.

If the correct PIN is entered the VFD will display . The “Operator Logged In” LED will also turn off.

If an invalid code is entered the VFD will display .

4.5 Modes of Operation

This section describes the different modes of operation for the MX8000 Receiver (normal mode and programming mode) and the options available in them.

4.5.1 Normal Mode

Normal mode consists of three options, one if the receiver is intended to be used with an automation system, one for manual operation, and one to just log the events without manual acknowledgments or automation communication.

4.5.1.1 Manual Operation

Requires a manual acknowledgment of each call or event from an operator.

How to Manually Acknowledge Calls:

When the call pending LED is flashing and the on-board annunciator is beeping:

1. Press the button to acknowledge the call.
2. Repeat step 1 until all calls are acknowledged and the display shows No More Data.

4.5.1.2 Automatic Operation

Event information is sent directly to the automation computer.

Note: If the automation system fails, the receiver will automatically switch to manual mode in less than 30 seconds. The switching time is twice the value set in Ack Timeout (See Table 5–5). The receiver will return to automatic mode after communication to the automation computer is restored.

4.5.1.3 Log Only

Log only mode will log event data without manual acknowledgments or communications with the automation computer. All event information is intended for printer output.

Notes:

- On initial power-up the receiver will default in manual operation. The receiver can be set to automatic or log only operation in program mode (see Section 5.3.1).
- The log only mode must not be used for UL installations.

4.5.2 Program Mode

In program mode all general, line card, and user profile options can be changed. See Section 5 – Programming for more detailed information on programming the receiver or refer to the Quick Chart, (Table A-1) for programming overview.

Note: The receiver will process calls while in the program mode.

4.6 Main Menu

This section gives detailed information about the items available in the Installer/operator menu options, which this manual will refer to as the main menu. The menu items available to each logged on user is dependent on the profile assigned to that user (see Table 4-4 for menu items for each profile). The user profile is assigned to each user through programming (see Section 5.5 for programming user profiles).

4.6.1 How to Display the Main Menu

Once a user has logged on to the system (see Section 4.4.4), follow these steps to view the main menu options:

1. Press the  button.

The VFD display will show the main menu options.

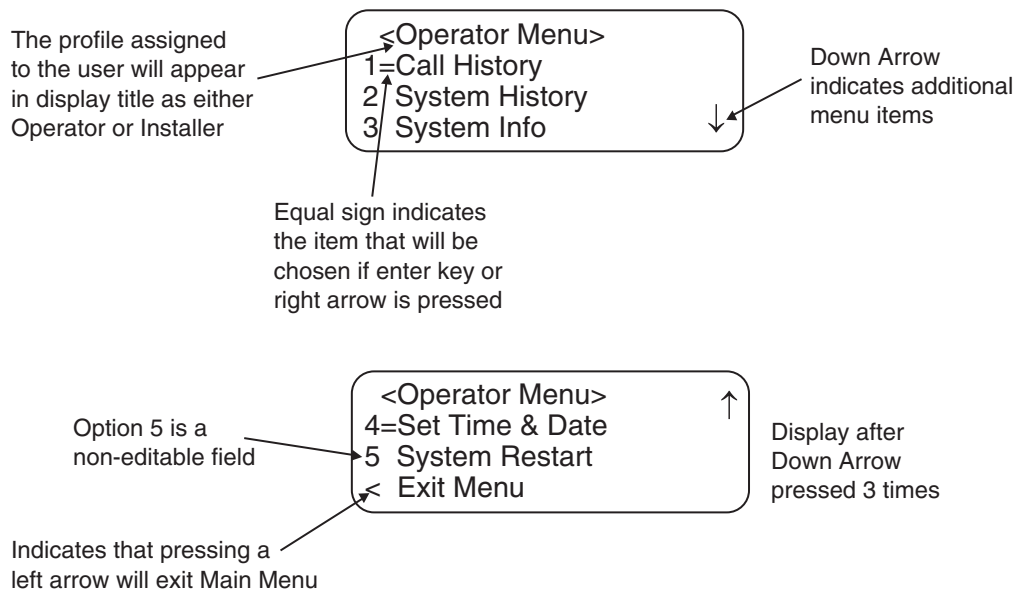

Figure 4-5: Main Menu Display

Note: The main menu display will remain visible for 15 minutes of idle time after which it will revert back to the manual or automatic display window. See Figure 4-3.

2. Choose the desired menu item. (See Figure 4-6.)

4.6.2 How to Maneuver Through Main Menu

Figure 4–6 indicates what keys on the touchpad are used to maneuver through the Main Menu.

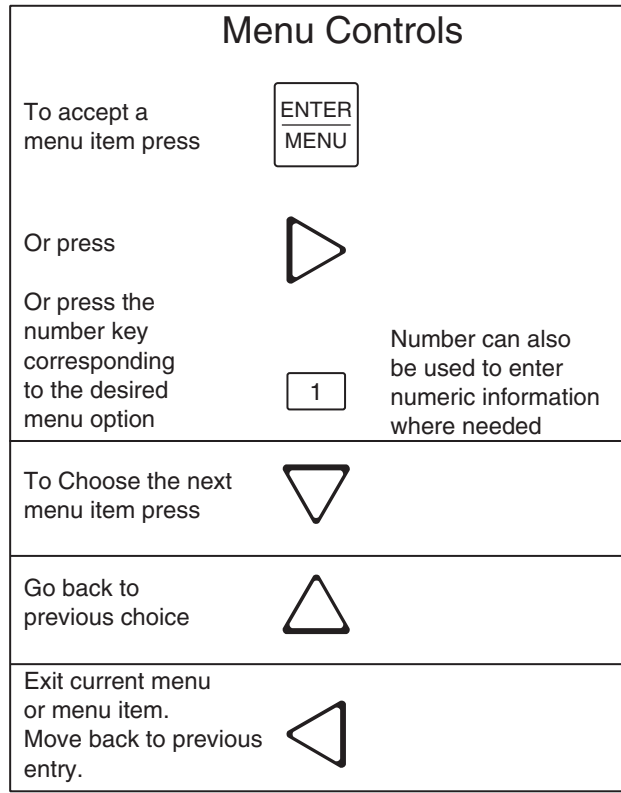

Figure 4–6: Main Menu Controls

4.6.3 Call History

Call history displays the calls that are in the history buffer.

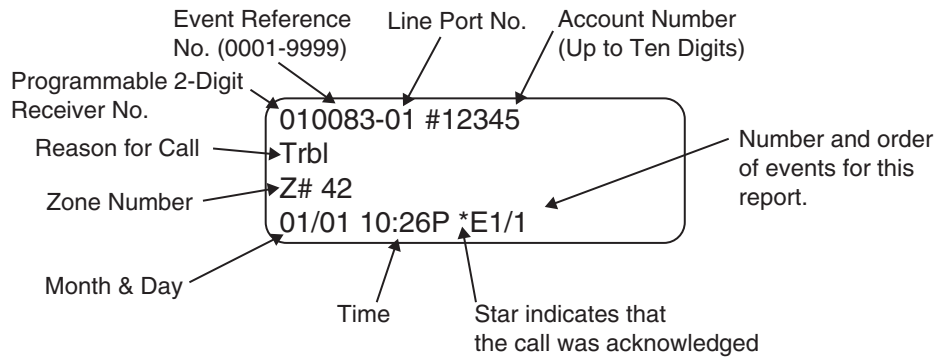



Figure 4–7: View of a Call History Screen

To display a specific event enter the reference number then press the . Press the  to go to most recent call. See Table 4–3 for display abbreviations.

4.6.4 System History

System history displays any events that are stored in the history buffer. System events are any events related to the receiver operation such as line card faults, low backup battery, AC power loss, log in, log out, system program change, communication failure to a printer or automation system, etc.

Note: Up arrow moves back to the previous event that occurred.

To display a specific event enter the event number (see Figure 4–8) then press the **ENTER MENU**. Press the ***** to go to most recent call.

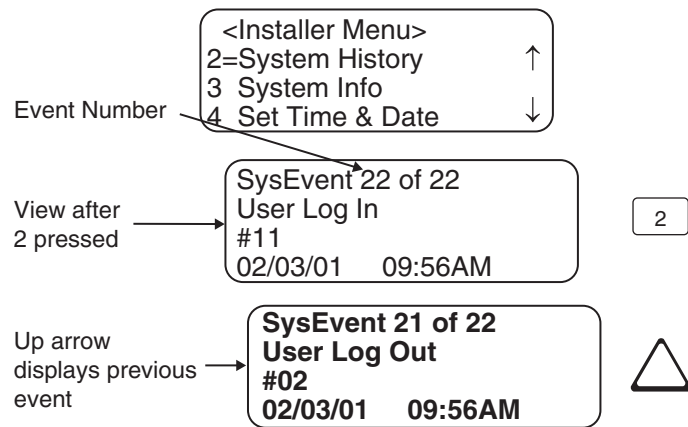

Figure 4–8: System History Display Sequence

4.6.5 System Info

System Info is a non-editable screen that displays the model number, the software revision, software date code, and receiver ID number. If a down arrow is pressed, the display will sequentially show the line card firmware information, which includes the firmware part number, the software date, and letter revision. The first line card firmware information display is for a MX8000–LC1 card, the second display is for a MX8000–LC3 card, and the third display is for a MX8000–LRR card.

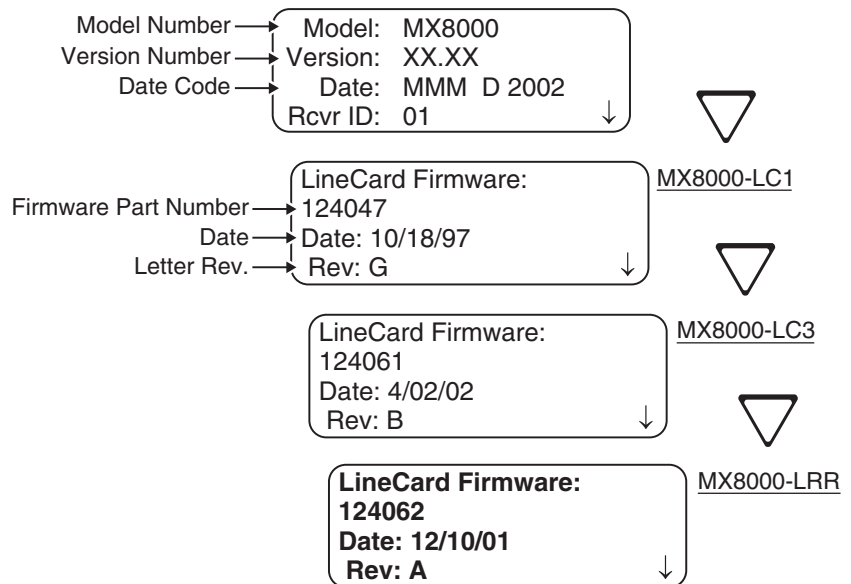



Figure 4–9: System Information Display

4.6.6 Set Time & Date

If Set Time & Date, is selected the operator can change the time and date currently displayed on the receiver. (See Figure 4–10 for setting time and date procedure.)

Note: If you make an error while setting the time and/or date, press  and re-enter the correct value.

Set Time and Date

1. Press the Menu button.
2. Press the 4 button.
3. Set the Hour (1 to 12). The field to be changed flashes. Press the Enter or > button to advance.
4. Set the Minutes. The field to be changed flashes. Press the Enter or > button to advance.
5. Set time to AM or PM. The field to be changed flashes. Press the Enter or > button to advance.
6. Set the Month. The field to be changed flashes. Press the Enter or > button to advance.

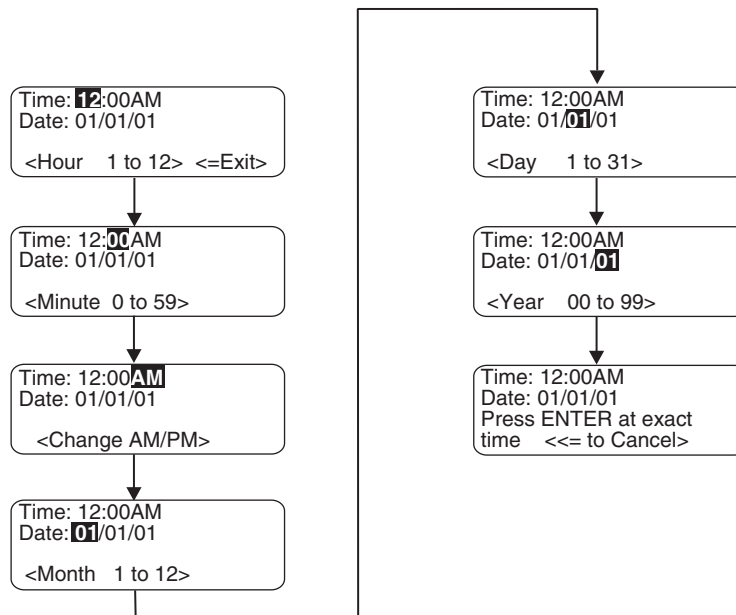

7. Set the Day. The field to be changed flashes. Press the Enter or > button to advance.
8. Set the Year (0 to 99). The field to be changed flashes. Press the Enter or > button to advance.
9. Press Enter button at the correct time to synchronize with.

Figure 4–10: Setting Time and Date Program Sequence



4.6.7 System Restart

System restart allows the operator or installer to restart the receiver. An installer has the option to set the receiver back to factory default settings, while an operator can only restart the receiver.

Note: The time and date set in the receiver will be saved. However, all of the call history will be lost.

Follow These Steps to restart the receiver:

Note: All messages must be acknowledged before a system restart procedure can be performed. If all messages are not acknowledged, cycle the receiver’s power to restart the system. If the power is cycled all unacknowledged messages will be lost.

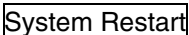
1. Log on to the receiver (see Section 4.4.4 for log on procedure).
2. Press the  button to view the main menu items.
3. Press  for .

The display reads

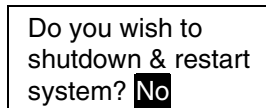

4. Press the  or  button to toggle  to .

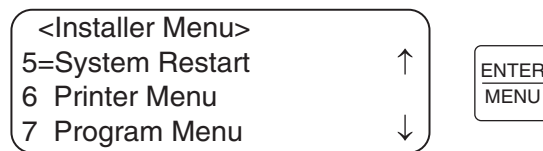

Figure 4–11: System Restart Display

5. Press . Users with an operator profile are done at this point.

The display reads

Do you wish to set to factory default settings?

Note: This display will only appear if the logged on User has an Installer Profile (see section 4.4.1).

6. Press the or button to toggle to .

Note: If you choose **Yes** all line card and user custom programming will be lost.

4.6.8 Printer Menu

In the print menu you can print customized reports by the type of alarm, edit the desired print output, and configure output for your printer.

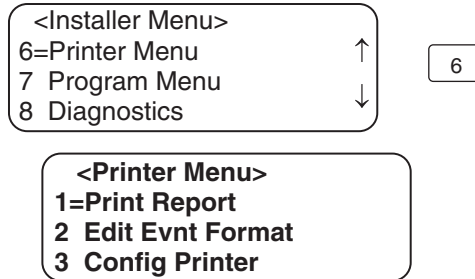

Figure 4–12: Print Menu Items

Table 4–6: Printer Menu Choices

Printer Menu	Choice 1	Choice 2	Comments	
Print Report	Call History	Priority 1 (Life safety signals-Fire, Duress)	Y Indicates that this item will print on this report. N Indicates that this item will not print on this report. The call History print will execute once you exit from "Choice 2". Note: Choice 2 settings are not retained in flash memory and have to be chosen for each call history printing.	
		Priority 2 (Property safety signals-Burg.)		
		Priority 3 (Supervisory signals)		
		Priority 4 (Trouble signals)		
		Priority 5 (All other signals)		
	System History		This option prints all the system events in the event history buffer.	
	System Config	Print All		Print all of the system and line card data described below under Program Data and Line Card #.
		Program Data		Print just the systems programmed data such as Operating Mode, Display Options, Communication Definitions, System Options, and Message Queue Options.
		Users List		Print a list of assigned MX8000 Users with their Level (Installer or Operator) and PIN Number.
		Line Card #		Print line card configurations per line card. These are the items programmed using the Line Card Menus.
Test Page			Print a test page.	
Line Card Statistics			Print line card statistics which include the device number, serial number, part number, physical line number, virtual receiver and line numbers, total calls for the line, calls today, and number of bad calls for the line.	

Table 4-6: Printer Menu Choices (cont'd)





Printer Menu	Choice 1	Choice 2	Comments
Edit Evnt Format	Date/Time	Y or N	Y Indicates that this item will print on a report. N Indicates that this item will not print on a report. Default setting is Y for all edit event format options. These settings are saved to flash memory.
	Format Type	Y or N	
	Ref Number	Y or N	
	Call Sep	Y or N	
	Device Num	Y or N	
	Prt Condensed	Y or N	
Config Printer	Line Terminator	CR or CRLF	CR = Carriage return. CRLF = Carriage return and Line feed.
	Offline Time	0 - 60 seconds	Offline time is how long the receiver will wait before giving a trouble indication after communication is lost with the printer. The default setting is 2 seconds. (30 second maximum for UL applications.)
	Switch Delay Time	0 - 60 seconds	Switch delay time is the duration the receiver will wait before switching to the backup printer after communication is lost with the primary printer. The default setting is 20 seconds.

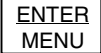

4.6.8.1 Print Report

Through the print report option you can choose to print the call history, system history, system configuration information, or just print a test page.

How to Print Call History

Follow these steps to print the call history:

1. Log on to the receiver (see Section 4.4.4 for log on procedure).
2. Press the  button to view the main menu items.
3. Press  for the printer menu. (See Figure 4-12.)
4. Press  for print report menu. (See Figure 4-13.)
5. Press  for call history options.

6. Press the  or  button to move through the call history menu choices. See Figure 4-14.

7. When the equal sign highlights the call history items you desire to print for this report press  or

 to toggle the setting between Y (yes print) or N (don't print).

8. Press  to exit menu.

How to Print System History

Follow these steps to print the system history:

1. Log on to the receiver (see Section 4.4.4 for log on procedure).

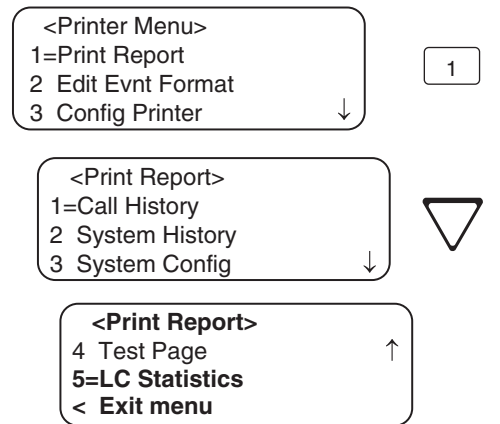

Figure 4-13: Print Report Menu Items

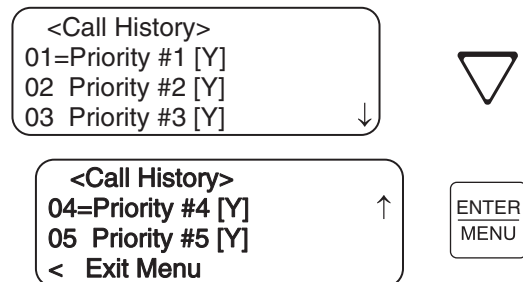













Figure 4-14: Call History Options

2. Press the  button to view the main menu items.
3. Press  for the printer menu. (See Figure 4–12.)
4. Press  for print report menu. (See Figure 4–13.)
5. Press  to print the system history.
6. Press  to exit menu.

How to Print System Configuration

Follow these steps to print the system configuration:

1. Log on to the receiver (see Section 4.4.4 for log on procedure).
2. Press the  button to view the main menu items.
3. Press  for the printer menu. (See Figure 4–12.)
4. Press  for print report menu. (See Figure 4–13.)
5. Press  to view system configuration options. See Figure 4–15.
6. Press the  or  button to move through the system configuration print choices.

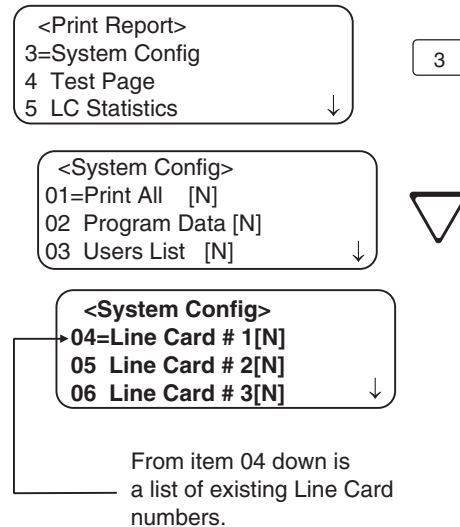
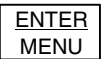









Figure 4–15: System Configuration Print Items

7. When the equal sign highlights an option press  or  to toggle the setting between Y (yes print) or N (don't print).
8. Press  to print the data and exit menu.

Note: These choices are not saved to flash memory and will have to be chosen each time that print system configuration is entered.





How to Print a Test Page

Follow these steps to print a test page:

1. Log on to the receiver (see Section 4.4.4 for log on procedure).
2. Press the  button to view the main menu items.
3. Press  for the printer menu. (See Figure 4–12.)
4. Press  for print report menu. (See Figure 4–13.)
5. Press  to print a test page.
6. Press  to exit menu.

How to Print Line Card Statistics





Follow these steps to print line card statistics:

1. Log on to the receiver (see Section 4.4.4 for log on procedure).
2. Press the  button to view the main menu items.
3. Press  for the printer menu. (See Figure 4–12.)
4. Press  for print report menu. (See Figure 4–13.)
5. Press  to print the statistics for all line cards.
6. Press  to exit menu.

4.6.8.2 Edit Event Format

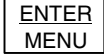
Edit event format allows you to configure what information will print on reports to the receiver.

Follow these steps to configure the report format:

1. Log on to the receiver (see Section 4.4.4 for log on procedure).
2. Press the  button to view the main menu items.
3. Press  for the printer menu. (See Figure 4–12.)
4. Press  for event format menu items. (See Figure 4–16.)
5. Press the  or  button to move through the event format choices. (See Table 4–7 for choice definitions.)

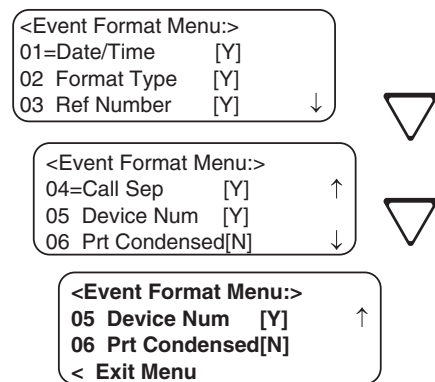

Figure 4–16: Event Format Menu Items

Table 4–7: Event Format Choices and Meaning

Event Format Options	Choices	Meaning
Date/Time	Y (Yes)	Y = Date and time will print for each report message to the printer.
	N (No)	N = Date and time will not print for each report message to the printer.
Format Type	Y (Yes)	Y = The reporting format type of the calling control panel will print for each report message to the printer.
	N (No)	N = The reporting format type of the calling control panel will not print for each report message to the printer. Note: The Format Type will be listed as a number, which represents the format used for that communication.
Reference Number	Y (Yes)	Y = The reference number will print for each report message to the printer.
	N (No)	N = The reference number will not print for each report message to the printer. (See Figure 4–7)
Call Separator	Y (Yes)	Y = Print a dashed-line between each message report to the printer.
	N (No)	N = Do not print a dashed-line between each message report to the printer.
Device Number	Y (Yes)	Y = Print the device number of the reporting message to the printer. N = Do not print the device number of the reporting message to the printer.
Print Condensed	N (No)	N = Printer output in normal mode.
	Y (Yes)	Y = All print data on a single line.

EXAMPLE OF THE EVENT PRINTOUT

For this example example, a yes answer was entered in the event format options for Date/Time, Format Type, Reference Number, Call Separator, and Device Number.

Example of Print in Normal Mode

```
05/25/2004 02:53:37PM
Device #: 1-34 Format #: 50 Reference #: 62
Account #: 1000
[New] Restore-Fire Alarm ID# 001 Group# 01 R110
-----
05/25/2004 02:54:03PM
Device #: 1-34 Format #: 50 Reference #: 64
Account #: 1000
[New] Restore-Fire Alarm ID# 001 Group# 01 R110
-----
```

Example of Print in Condensed Mode

```
05/25/2004 02:53:37PM D#:1-34 F#:50 Ref#:62 A#: 1000 [New] Restore-Fire Alarm ID# 001
Group# 01 R110
-----
05/25/2004 02:54:03PM D#:1-34 F#:50 Ref#:64 A#: 1000 [New] Restore-Fire Alarm ID# 001
Group# 01 R110
-----
← .....Printer Margins ..... →
```

In the above Condensed Print example: D# = Device Number, F# = Format Type Number, Ref# = Reference Number, A# = Account Number,

7. When the equal sign highlights each option press  or  to toggle the setting between Y (yes print) or N (don't print).



Note: *These settings are saved to flash memory.*

8. Press  to exit menu.



4.6.8.3 Configure Printer

Depending on the printer you are using it may require that this be set to either carriage return or carriage return with a line feed.

Follow these steps to configure the printer:

1. Log on to the receiver (see Section 4.4.4 for log on procedure).
2. Press the  button to view the main menu items.
3. Press  for the printer menu. (See Figure 4–12.)
4. Press  for configure printer menu items.



The display will be flashing on the line terminator field.

5. Press the  or  button to toggle between CR or CRLF. (See Table 4–6.)
6. When the desired setting is flashing press .

The display will now flash on the offline time field.

7. Enter the desired time (from 01-99 seconds), 30-second maximum in UL applications.
8. Press .

The display will now flash on the switch delay time field.

9. Enter the desired time (from 01-99 seconds).
10. Press .
11. Press  to exit menu.

4.6.9 Program Menu

If program is selected from the main menu the system will enter into “Program Mode”. (See Section 4.5 for information on modes of operation.) In program mode you can program all the general options, line card options, and user list. (See Appendix A, Table A–1 for *Programming Quick Chart*.)

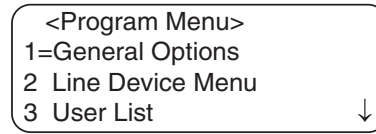

Figure 4–17: Program Menu Items

4.6.10 Diagnostics Menu

The diagnostics menu items can be used while testing and troubleshooting the system.

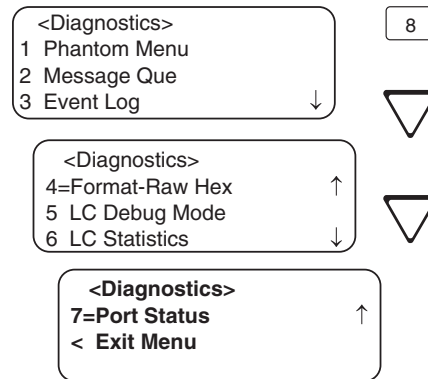

Figure 4–18: Diagnostics Menu Items

4.6.10.1 Phantom Menu

The phantom menu contains list of various communication format phantom signals (see Table 4–8) that can be used to test the receiver or automation software configurations. For example, you set a line cards parameters for a particular communications format and would now like to verify that this new configuration will communicate with other communication formats, you can send phantom signals in the formats you wish to test that line card with. To use the phantom menu to test a format:

1. Select Phantom Menu in the Diagnostics Menu.
2. Scroll through the list of formats and select the format to be tested.
3. Exit the Phantom Menu. Messages will be sent to the printer in the format selected.

Table 4–8: Phantom Signals Formats List

Choice	Format	Choice	Format
01 DCS	DCS	12 SIA D1	ADEMCO High Speed (SIA D1)
02 CID	Contact ID®	13 ADM42 Cksum	ADEMCO 4/2 format w/ checksum
03 ITI	ITI format	14 SIA D1 Cksum	ADEMCO High Speed w/ checksum (SIA D1 w/checksum)
04 BFSK	BFSK	15 ACRON TOUCH TONE	Acron TouchTone
05 3/1	3/1 format	16 ADM41 Cksum	ADEMCO 4/1 format w/ checksum
06 3/2	3/1 format w/checksum	17 FBII 4+3+1	FBII 4+3+1
07 4/1	4/1 format	18 Modem IIE	Modem IIE format
08 4/2	4/2 format	19 SIA 2000 (see note)	SIA 2000 format
09 FSK0	FSK0		
10 FSK1	FSK1		
11 FSK2	FSK2		

Note: This format is not currently supported by the MX8000.

4.6.10.2 Message Que

Message Que gives a visual indication of how full the message queue is. It does this with both a percentage indication and a bar graph (made of *'s). Each * is approximately 5%.

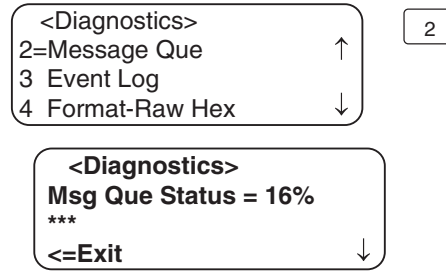

Figure 4–19: Message Queue Level

4.6.10.3 Event Log

Event Log allows you to print out a range of reference numbers to the port designated for diagnostic use. This can be used as a troubleshooting tool while correlating alarm messages from the receiver to the automation computer.

For example, if the automation computer indicated a report that you are not familiar with, you would enter the reference number for that report in the event log and the raw data would be output to the diagnostic port. From the raw data you could determine what the signal was and make adjustments to the automation computer for future signals like that one.

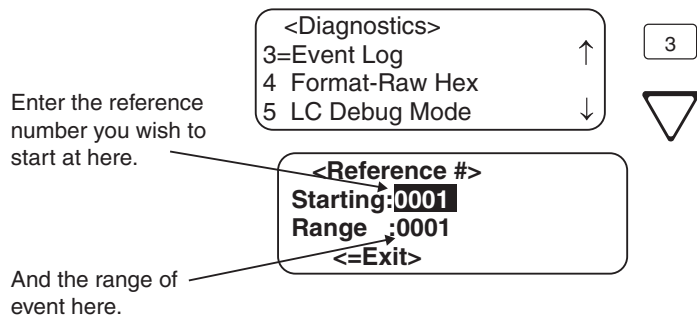

Figure 4–20: Event Log Display

4.6.10.4 Format

Format designates the type of output you wish for the Event Log report. The output format can be in raw ASCII, a printer format, or one of the receivers' automation communication formats (see Section 8 for automation protocols).

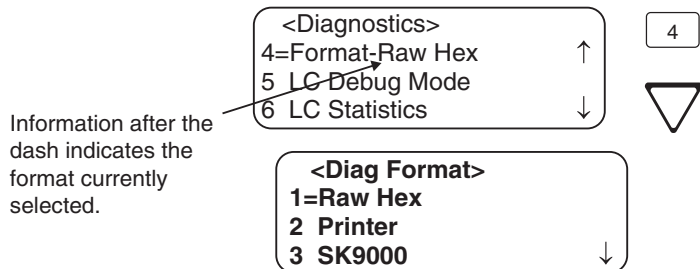



Figure 4–21: Diagnostic Formats

4.6.10.5 LC (Line Card) Debug Mode

LC debug enables the receiver to generate detailed history of handshake sequences to the call buffer. This information can be used for troubleshooting.

Use the  right arrow or to toggle the line card selection between “Yes” or “No”. Press  to exit and “Yes” to save changes.

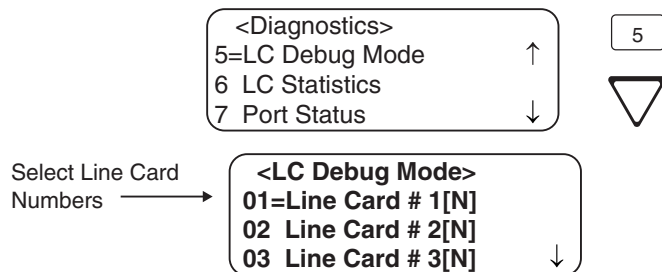



Figure 4–22: Select LC Debug Mode by Line Card

4.6.10.6 LC (Line Card) Statistics

LC (Line) statistics allows you to view the call statistics of a specific Line in comparison to the total number of calls received.

To view a line cards call statistics, follow these steps:

1. From the installer menu (See Section 4.4) press **8** for Diagnostic menu.
2. Select **6** for LC Statistics. See Figure 4-23.
3. Select the number corresponding to the Device type you want to view. See Figure 4-23.
4. Select the number of the line you wish to view. See Figure 4-23.
5. Press  left arrow to exit.

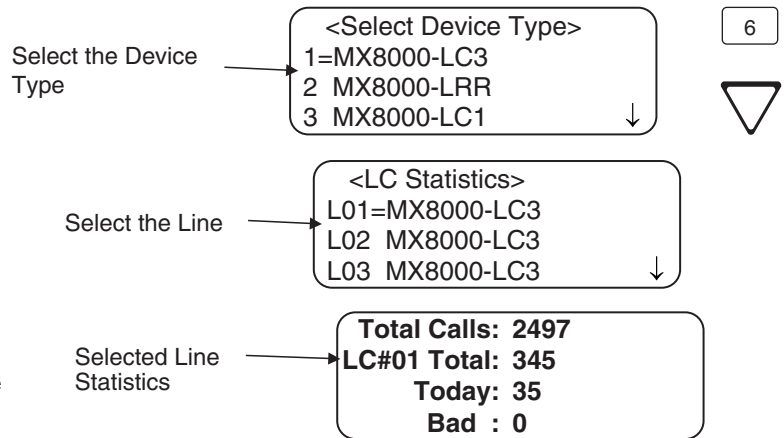



Figure 4-23: Line Statistics Display

4.6.10.7 Port Status

Port status allows you to view the current status of any of the communication ports.

To view the status of one of the communication ports, follow these steps:

1. From the installer menu (See Section 4.4) press **8** for Diagnostic menu.
2. Select **7** for Port Status.
3. Select the communication port you wish to view. See Figure 4-24 and Figure 4-25. Table 4-9 provides the meaning of the arrows shown on the display.
4. Press  left arrow to exit.

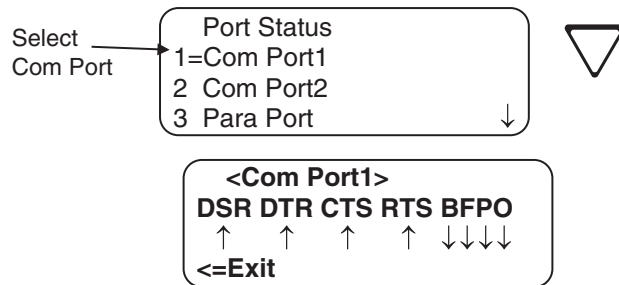

Figure 4-24: Port Status View of Serial Port

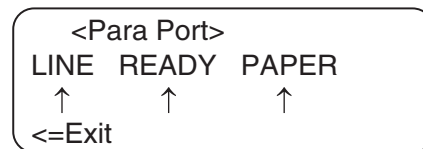

Figure 4-25: Parallel Port Status View

Table 4–9: Abbreviation Display Character Meanings/High Low Status

Abbreviated Character	Meaning	↑ (Bit High)	↓ (Bit Low)
Serial Port (Com 1 & Com 2)			
DSR	Data Set Ready	Ready	Not Ready
DTR	Data Terminal Ready	Ready	Not Ready
CTS	Clear to Send	Ready	Not Ready
RTS	Request to Send	Ready	Not Ready
B	Receive Break	Received Break	Ready
F	Framing Error	Framing Error	Ready
P	Parity Error	Parity Error	Ready
O	Overrun Error	Overrun Error	Ready
Parallel Port			
LINE	printer on-line status.	Printer On-line	Printer Off-line
READY	Printer ready status	Printer ready	Printer not ready
PAPER	Paper status	Paper status OK	Out of paper

4.7 Listen-In and Hang Up

This section explains how to operate the receiver for listen-in calls. Some panels that perform listen-in send a listen-in indicator (Contact ID® E606 1 and 3 or SIA LF and LE) included in the reported message to the receiver. Any panel that does not send this message must be added to the Listen-In Account List (see Section 5.4.2.4 for the MX8000–LC3 or 5.4.4.4 for the MX8000–LC1).

When a listen-in call is received by the MX8000, the VFD display will indicate the account number and (depending on the panel) the listen-in timeout period. The listen-in LED on the line card will be illuminated to confirm the line card indication.

Listen-In has two modes of operation called common and PBX. When operating in the common mode, the line is available to be monitored locally for a period of time that is programmed into the MX8000 and the line card continues to monitor the call. When operating in the PBX mode, a listen-in call is transferred to a phone number that is programmed into the MX8000 and the line card will release the call.

4.7.1 Extend Manual (Common) Listen-In Operation

Follow these steps to extend common listen-in time period:

1. Press LISTEN .
2. Enter the Line number.
3. Pick up the telephone the listen-in call is on. See Figure 4–26 for a diagram of how the listen-in phone should be connected (in parallel) with the phone line of the Line.

Note: Figure 4–26 shows an MX8000-LC3 3-line card. The phone connection is the same when using an MX8000-LC1 1-line card.

4. Perform the listen-in procedures for that panel (refer to panel operation manual).

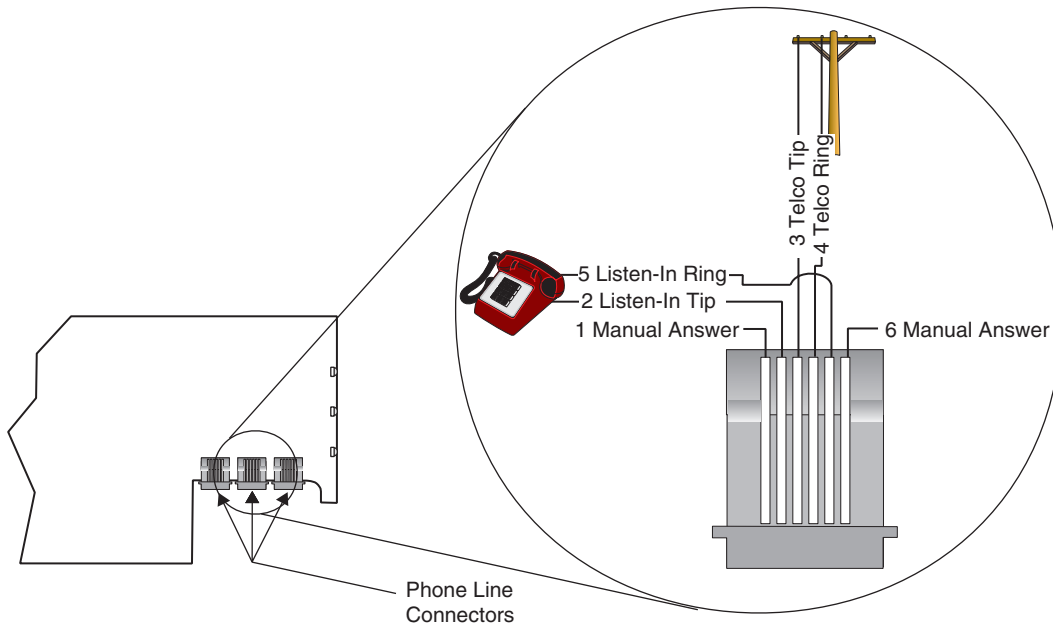

Figure 4-26: Phone Connector Pin-Out and Listen-in Wiring Diagram

4.7.2 PBX Operation

Prior to performing listen-in functions on a PBX phone line system the receiver must be set up with the proper listen-in mode and PBX string. Refer to Sections 5.1 and 5.4.2.4 (MX8000-LC3) or 5.4.4.4 (MX8000-LC1) to properly program the receiver to handle PBX listen-in calls.

4.8 Testing the System

IMPORTANT:

The MX8000 should be tested regularly to ensure complete and proper operation.

Because there are so many variations in dialer parameters and phone line conditions, the only way to be absolutely certain that all subscribers can communicate with the MX8000 is to test every subscriber's dialer individually. Subscribers must test their communicators every 30 days to make sure the MX8000 receives the information.

When you install a new MX8000, test every manufacturers' panels for each format. This is necessary because different manufacturers' panels may operate differently even if all panels use the same format.

Section 5 Programming



This section lists the programmable features in programming mode and the procedures for each of them. The options available are general options, line card options, and user options.

NOTE

After you complete your programming of the receiver, it is recommended that you make a printout of the programmed values for reference. To make a printout of the programmed values, see “How to Print System Configuration” on page 4–13 and perform a Print All operation.

5.1 How to Enter Program Mode











Follow these steps to enter into program mode:

1. Log on to the receiver (see Section 4.4.4 for log on procedure).
2. Press the  button.
3. Press the  button.
4. Select the option you wish to program. (See Section 5.2 for options.)

5.1.1 Programming Fields

In program mode there are three types of programming fields that data can be entered into. Table 5–1 list the three types of fields and the various parameters associated with them.

Table 5–1: Types of Programming Fields

Type of Field	Control Keys	Comments
Numeric	 through  or   keys	These fields require a numeric entry only.
List	  keys	Predefined choices are put in a list and can be selected by pressing the up or down arrow keys.
Edit	 through  or   keys	Enter a number from the numeric keypad or enter any special characters by pressing the up or down arrow keys.

5.1.2 How to Maneuver Around in Program Mode

Figure 5–1 shows what keys on the touchpad are used to maneuver in program mode.







Menu Controls	
To accept a menu item, press	
Or press	
Or press the number key corresponding to the desired menu option	 Number can also be used to enter numeric information where needed
To Choose the next menu item, press	
Go back to the previous choice	
Exit current menu or menu item. Move back to previous entry.	

Figure 5-1: Programming Controls

5.2 Programming Choices

In programming mode your first set of choices are general options, line devices, and user list. (Each of these choices will be described in greater detail in the following sections.) Figure 5-2 shows what the display will look like before and after the down arrow is pressed.

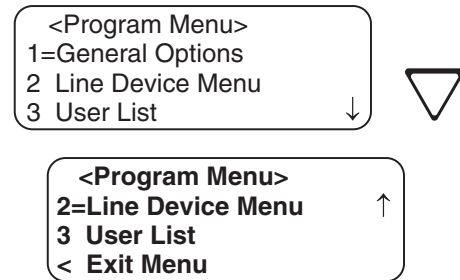

Figure 5-2: Program Menu Choices

5.3 General Options

The features available for programming under general options are operation mode, display options, communications, system options, message queue options, slave list, and virtual receiver/line numbers.

Table 5-2 lists the available choices under General Options and gives a description of those choices.

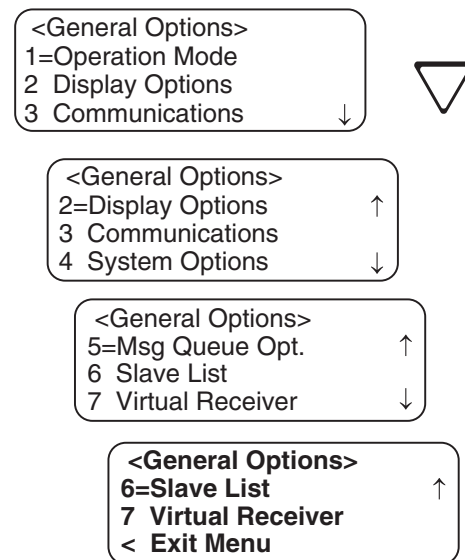

Figure 5-3: General Options Display

Table 5–2: General Options Items and Description

The below table is organized into the order that menu items are displayed when General Options has been selected from the Program Menu. The first column reflects the first menu displayed, followed by the subsequent menu displays based on the item selected. For example, if on the General Options screen you select Operation Mode, the next screen will allow the selection of Manual, Automatic, or Log Only.

General Options Items	Level 1 Choices	Level 2 Choices	Level 3 Choices	Comments
Operation Mode	Manual			See Section 5.3.1 for additional information on Operation Modes.
	Automatic			
	Log Only			
Display Options	Language	English		See 5.3.2.1.
		Español		Not available at this time
	Time Display	AM/PM		AM/PM is used for 12-hour time clock displays. See 5.3.2.2.
		24 Hour		
	Date Format	M/D/Y		M = month, D = day, and Y = year. See 5.3.2.3.
		D-M-Y		
		Y-M-D		
	Daylight Savings	Yes		See 5.3.2.4.
		No		
	ITI (Edit Options)	Attempts	Yes	Affects printer output for ITI calls only.
			No	
		CPU Time	Yes	
			No	
		CPU Type	Yes	
			No	
		Panel Rev	Yes	
	No			
	Arming Level	Yes		
	FMT (Edit Format options)	FSK1	Code	If “English” is selected then the printer and VFD output for calls of these formats will be text descriptions. If “Code” is selected then the printer and VFD output for calls of these formats will be the Code and Zone numbers.
			English (default)	
		BFSK	Code (default)	
English				
SIA		Code	If “English” is selected, the printer and VFD output will be text. If “Code” is selected then the printer and VFD will display the SIA codes followed by zone or other information.	
		English (default)		
CID		Code (default)	This option only affects the ADEMCO 8000 automation protocol output. If “English” is selected each event will be sent to the automation as two SIA events; the first with the two digit Group number and the second with the three digit ID number. If “Code” is selected, each event is sent as eleven digits; two digits Message type, one-digit Event Qualifier, three-digit Event Code, two-digit Group Number, and three-digit ID number.	
		English		
PULSE		0 .. 9	Digits 0 through 9.	
	0 .. F (default)	Digits 0 through 9 and A through F.		

Table 5-2: General Options Items and Description (cont'd)

General Options Items	Level 1 Choices	Level 2 Choices	Level 3 Choices	Comments
Display Options (continued)	FMT (Edit Format options continued)	SK9000	Packed (default)	Each data packet to the automation computer contains multiple events.
			Unpacked	Each data packet to the automation computer contains a single event.
		ACRON	Zero (default) Space	Defines leading character in a 3-digit account number as a zero or space.
		HISPEED	SIA (default) Hispeed	Printer output will be in SIA format or in a raw data high speed format.
	Hold Last Event	Yes		VFD will display the last or oldest unacknowledged event instead of the date/time display. See 5.3.2.7.
		No (default)		
	VFD Brightness	Off		Affects main menu display only. All other displays are always at maximum. See Section 5.3.2.8.
		25% (default)		
		50%		
		75%		
MAX				
Communication	Port Functions	Com1	Unused/Automation/ Printer/	Rules for Port Configuration: 1. Functions in Brackets [] will not appear unless "Automation" is selected for Com1 function. 2. Functions in { } will not appear unless "Printer" is selected in Com1 or Par. 3. A function may be selected only once in the 3 ports (only one printer, only one Diag, and so on). 4. All ports may be configured "Unused". See Section 5.3.3 for additional information.
		Com2	Unused/[Auto Bkp]/ [Auto Bkp Prn]/ {Print Bkp}/Diag/ Printer	
		Par (Parallel)	Unused/[Auto Bkp]/ Printer/Diag	
	Com Port 1	Baud Rate	38400/19200/9600/ 7200/4800/2400/ 1200/ 600/300/110	See Section 5.3.3.2.
		D (# Data Bits)	7, 8	
		S (# Stop Bits)	1, 2	
		P (Parity)	Even, Odd, No	
		PortMon (Port Monitor)	Yes No	When set to Yes (recommended) the computer ready line is monitored. None = no supervision
		F (Flow Control)	Hdwr, None Sfwr	
		Init String		See Section 5.3.3.4.
	Com Port 2	Same as Com Port 1		See Section 5.3.3.3.
	Par Port	Edit Init String		See Section 5.3.3.4.
	Automation Config	Format	SK9000, ADEM 8000, ADEM 685, FBII 220, CAPS, ITI Gen, ITIComp	See 5.3.3.5.
		Hex	Y = Enabled N = Disabled	Only visible if ADEM 8000 or SK9000 format is selected.
		Heart Beat	Y = Enabled N = Disabled	
		Time (of Heartbeat)	10-600 Seconds	
		Ack timeout	1-120 Seconds	

Table 5–2: General Options Items and Description (cont'd)

General Options Items	Level 1 Choices	Level 2 Choices	Level 3 Choices	Comments	
Communication (continued)	Automation Config (continued)	<Cfg>		Term = 013, Head = 010, ACK = 006, NACK = 021, TR = 005, TH = 084, TT = 020	Only visible if ADEMCO 685, FBI1220, or CAPS ONLY format is selected. Note: Setting ACK and NACK to 0 disables the ACK and NACK.
		<ITI>	Log Records	Y = Enabled N = Disabled	Only visible if ITI Gen or ITIComp format is selected.
			Enable External ID	Y = Enabled N = Disabled	
			Supervisory Character		
			No Data Character		
			Generic Revision	6.1 6.2	
		Annunciator Configuration	Printer	Yes or No	See Section 5.3.3.6.
	Bkp Printer		Yes or No		
	Auto Comp		Yes or No		
	Bkp Auto Comp		Yes or No		
	Battery		Yes or No		
	Device		Yes or No	Device corresponds to loss of communication with slave or line card.	
	Line Fault		Yes or No		
	AC Power		Yes or No		
	Buffer Full		Yes or No		
	Listen In		Yes or No	Listen in must be set to No for UL installations.	
	Call Pending		Yes or No		
	Aux Relay Cfg	Printer	Yes or No	See Section 5.3.3.7.	
		Bkp Printer	Yes or No		
		Auto Comp	Yes or No		
		Bkp Auto Comp	Yes or No		
		Battery	Yes or No		
		Device	Yes or No		Device corresponds to loss of communication with slave or line card.
		Line Fault	Yes or No		
		AC Power	Yes or No		
		Buffer Full	Yes or No		
		Listen In	Yes or No		Listen in must be set to No for UL installations.
Call Pending		Yes or No			
System Options	Battery Backup Cfg	No Battery Bkp		See Section 5.3.4.	
		Battery Bkp			
		DC Bkp			
	Receiver Mode	MstrAuto, MstrPrn, SlvAuto, SlvPrn, or Single			
Receiver ID No.	01-99				

Table 5–2: General Options Items and Description (cont'd)

General Options Items	Level 1 Choices	Level 2 Choices	Level 3 Choices	Comments
System Options (continued)	Bad Data Blocks	Strip Bad		If this is selected an indicator will be sent to the automation computer that indicates a bad data block was received.
		Send Bad		Same as Strip Data except the bad data block is sent with the indicator.
	Auxiliary Relay Normal State	Off		See Section 5.3.4.
		On		See Section 5.3.4.
	Clock Source	60 Hz		
		50 Hz		
Internal				
Message Queue Options	% Warning Lvl On	10 to 99 %	(Default = 75%)	The percentage of how full the message queue can get before a trouble indication occurs.
	% Warning Lvl Off	01 to 90%	(Default = 50%)	What percentage the message queue must go back down to in order to clear a trouble indication.
	Event Release	1, 20 to 120 sec.	(Default = 060 sec.)	Time from call beginning until events released to system.
Slave List (Shown on Master Receiver Only)	Add Slave	2-digit Slave No.		Enter 8000 receiver number as a 2-digit entry. See Section 5.3.6.
	View Slave	S01 = 8000 Slave S02 = 8000 Slave		View 8000 receiver slave numbers. See Section 5.3.6.
	Delete Slave	S01 = 8000 Slave S02 = 8000 Slave		Delete 8000 receiver slave numbers. See Section 5.3.6.
Virtual Receiver/ Line Numbers	Receiver Number	2-digit Virtual Receiver #		See Section 5.3.7.
	Line Number	3-digit Virtual Line #		See Section 5.3.7.

5.3.1 Operation Mode

Operation mode chooses how the receiver will operate in normal mode (manual, automatic or log only operation). Table 5–3 breaks down the choices available under operation mode menu item.

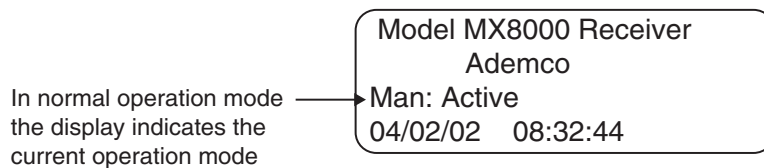

Figure 5–4: Normal Operating Mode Display Indicating Manual Operation





Table 5–3: Operation Mode Choices and Descriptions

Choices	Description	Default
Manual	Requires manual acknowledgments of each call or event from an operator.	✓
Automatic	All event information is sent directly to the automation computer and must be acknowledged by the automation software.	
Log Only	All event information is internally acknowledged and put into event history buffer.	



Note: Defaults refer to settings from the factory. Once the receiver is programmed, the system will power up in the programmed operation mode.

5.3.1.1 How to change the operation mode

Follow these steps to change the operation mode of the receiver:

1. Log on to the receiver. (See Section 4.4.4 for log on procedure.)
2. Press  button.
3. Press  for program menu.
4. Press  to choose general options.
5. Press  to choose operation mode.

The current operation mode will flash in the display.

6. Press the  or  button to move through the operation mode choices.

Note: Each additional press of the up or down arrow key will toggle the operation mode setting to the next choice.

7. When the display flashes on the desired operation mode press .

5.3.2 Display Options

Display options let you customize the visual outputs of the receiver. These items include language formats, the time display, how events are sorted to the VFD display, or whether or not to hold unacknowledged events. Table 5–4 lists the available choices and gives a description of those choices.

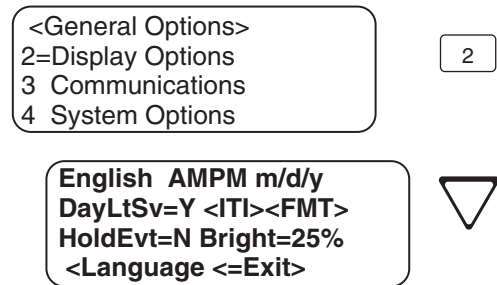

Figure 5–5: View of Display Options



Table 5–4: Display Options and Descriptions

Display Menu Items	Choices	Default	Comments
Language	English	✓	See Section 5.3.2.1 for step-by-step instructions.
	Español		Not available at this time.
Time Display	AM/PM	✓	AM/PM is used for 12-hour time clock displays. See Section 5.3.2.2 for step-by-step instructions.
	24 hour		Military time standard. See Section 5.3.2.2 for step-by-step instructions.
Date Display	m/d/y	✓	m = month, d = day, and y = year.
	d-m-y		See Section 5.3.2.3 for step-by-step instructions.
	y-m-d		
Daylight Savings	Yes	✓	See Section 5.3.2.4 for step-by-step instructions.
	No		





Table 5-4: Display Options and Descriptions (cont'd)

Display Menu Items	Choices	Default	Comments
ITI (Edit Options)	Attempts	No	See Section 5.3.2.5 for step-by-step instructions.
	CPU Time	No	
	CPU Type	No	
	Panel Rev	No	
	Arming Level	No	
FMT (Edit Format Options)	FSK1	English	If "English" is selected then the printer and VFD output for calls of these formats will be text descriptions. If "Code" is selected then the printer and VFD output for calls of these formats will be the Code and Zone numbers. See Section 5.3.2.6 for step-by-step instructions.
	BFSK	Code	
	SIA	English	If "English" is selected, the printer and VFD output will be text. If "Code" is selected then the printer and VFD will display the SIA codes followed by zone or other information. See Section 5.3.2.6 for step-by-step instructions.
	CID	Code	This option only affects the ADEMCO 8000 automation protocol output. If "English" is selected each event will be sent to the automation as two SIA events; the first with the two digit Group number and the second with the three digit ID number. If "Code" is selected, each event is sent as eleven digits; two digits Message type, one-digit Event Qualifier, three-digit Event Code, two-digit Group Number, and three-digit ID number. See Section 5.3.2.6 for step-by-step instructions.
	PULSE	0 .. 9	If "0 .. 9" is selected hexadecimal digits B through F are forced to 0 as in the way the SK9000 receiver does it, or if "0 .. F" is selected digits are sent as is.
	SK9000	Packed	Each data packet to the automation contains a single (unpacked) or multiple (packed) events.
	ACRON	Zero	Defines leading character in a 3-digit account number as a zero or space.
	HISPEED	SIA	Printer output will be in SIA format or in a raw data high speed format.
Hold Last Event	Yes		VFD will display the last acknowledged event instead of the date/time display in the auto mode. In manual mode the display will show the oldest unacknowledged event.
	No	✓	
Bright	Off		Set the brightness of the Normal Operating Mode Display screen. All other screens will be displayed at Maximum. See Section 5.3.2.8 for step-by-step instructions.
	25%	✓	
	50%		
	75%		
	Max		





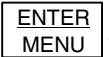

5.3.2.1 How to Change Language Display

1. Enter program mode. (See Section 5.1.)
2. Press for general options.
3. Press for display options.
4. Press  until the display flashes on the language format field.
5. Press the  or  button until the display flashes on the desired setting.
Note: Only English format is available at this time.
6. Press .







5.3.2.2 How to Change Time Format Display

1. Enter program mode. (See Section 5.1.)
2. Press  for general options.
3. Press  for display options.
4. Press  until the display flashes on the time format field.
5. Press the  or  button until the display flashes on the desired setting.
6. Press .

5.3.2.3 How to Change Date Format Display

1. Enter program mode. (See Section 5.1.)
2. Press  for general options.
3. Press  for display options.
4. Press  until the display flashes on the date format field.
5. Press the  or  button until the display flashes on the desired setting.
6. Press .

5.3.2.4 How to Turn “On” or “Off” Daylight Savings.

1. Enter program mode. (See Section 5.1.)
2. Press  for general options.
3. Press  for display options.
4. Press  until the display flashes on the daylight savings field.
5. Press the  or  button until the display flashes on the desired setting.
6. Press .







5.3.2.5 How to Edit ITI Options

If one of the following ITI options is turned on (set to Yes) then the VFD and printer outputs will include that information.

- Attempts
- CPU Time
- CPU Type
- Panel Rev
- Arming Level

To set these display options follow these steps:

1. Enter program mode. (See Section 5.1.)
2. Press  for general options.







3. Press  for display options.
4. Press  until the display flashes on the <ITI> savings field.
5. Press .
6. Press the  or  button until the equal sign is on the desired option.
7. Press  to change the setting of that option.

Note: Additional presses of the enter button will toggle the setting between Yes and No.

8. Repeat steps 6 and 7 for any other ITI display options you wish to edit.

5.3.2.6 How to Edit Format Options

To set these display options follow these steps:

1. Enter program mode. (See Section 5.1.)
2. Press  for general options.
3. Press  for display options.
4. Press  until the display flashes on the <FMT> savings field.
5. Press .
6. Press the  or  button until the equal sign is on the desired option.
7. Press  to change the setting of that option from “English” to “Code”.







For Pulse Format “0 to 9” or “0 to F” can be selected. For SK9000 “Packed or Unpacked” can be selected.

Note: Additional presses of the enter button will toggle the setting between English and Code.

8. Repeat steps 6 and 7 for any other FMT options you wish to edit.

5.3.2.7 How to Set Hold Last Event



Hold last event will cause the VFD to display the last acknowledged event instead of the date/time display in the auto mode. In manual mode the display will show the oldest unacknowledged event. To set the hold last event function, proceed as follows:

1. Enter program mode. (See Section 5.1.)
2. Press  for general options.
3. Press  for display options.
4. Press  until the display flashes on the hold last event field.
5. Press the  or  button until the display flashes on the desired setting.
6. Press .

5.3.2.8 How to Set VFD Brightness

Note: This field affects the Normal Operating Display screen ONLY. All other displays will be shown at maximum.

1. Enter program mode. (See Section 5.1.)

2. Press **1** for general options.
3. Press **2** for display options.
4. Press  until the display flashes on the bright field.
5. Press the  or  button until the display flashes on the desired setting.
6. Press **ENTER MENU**.

5.3.3 Communications

In the communication option the installer can configure the communication ports, automation configuration, annunciator configurations, and the auxiliary relay configurations.

Table 5–5 lists the available choices and gives a description of those choices.

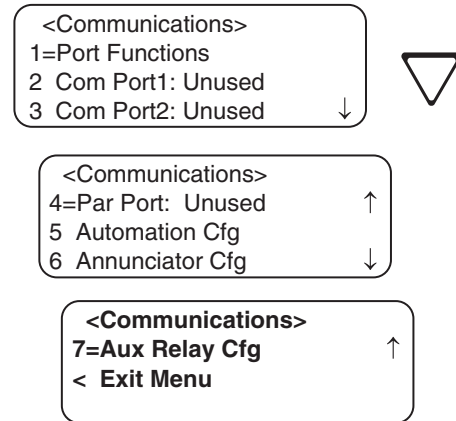

Figure 5–6: Communications Options Menu

Table 5–5: Communications Options and Description

Communications Menu	Choices	Options	Default	Comments		
Communications Port Functions	Com1	Unused	✓	Rules for Port Functions: 1. Functions in Brackets [] will not appear unless “Automation” is selected for Com1 function. 2. Functions in { } will not appear unless “Printer” is selected in Com1 or Par. 3. A function may be selected only once in the 3 ports (only one printer, only one Diag, and so on). 4. All ports may be configured “Unused”. 5. Only Com Port 1 can be set as the primary automation port.		
		Automation				
		Printer				
	Com2	Unused	✓			
		Diagnostics			Would output raw Hex-ASCII code.	
		Printer			English output to a printer.	
		[Auto Bkp]			Would act as a backup automation port if a fault occurred with the primary automation port.	
		[Auto Bkp Prn]			Would act as a backup print output port if a fault occurred with the automation port.	
		[Print Bkp]			Would act as a backup printer port if a fault occurred with the primary printer port.	
	Par	Unused	✓		Note: The receiver printer port is enabled at the factory. You will receive a trouble condition when a printer is not attached.	
		Diagnostics				Would output raw Hex-ASCII code.
		Printer				English output to a printer.
		[Auto Bkp Prn]				Would act as a backup print output port if a fault occurred with the automation port.

Table 5-5: Communications Options and Description (cont'd)

Communications Menu	Choices	Options	Default	Comments
Com Port 1	Baud	38400	✓	
		19200		
		9600		
		7200		
		4800		
		2400		
		1200		
		600		
		300		
		110		
	D (# Data Bits)	7		
		8	✓	
	S (# Stop Bits)	1	✓	
		2		
P (Parity)	Even			
	Odd			
	No	✓		
PortMon (Port Monitor)	Yes	✓	When set to Yes (recommended) the computer ready line is monitored.	
	No			
F (Flow)	Hdwr	✓	Unidirectional communication	
	Sfwr			
	None		No supervision	
Init Str (Initialization String)			Two 20-character ESC command sequences. See Section 5.3.3.4 for step-by-step instructions.	
Com Port 2				Same as Com Port 1
Par Port (Parallel Port)	Edit Init Str (Initialization String)			Two 20-character ESC command sequences. See Section 5.3.3.4 for step-by-step instructions.
Automation Cfg	Format	SK9000		See Section 5.3.3.5 for programming steps. See Section 8 for more information on automation formats.
		ADEM 8000	✓	
		ITI Gen		
		ITIComp		
		ADEM 685		
		FBII 220		
		CAPS		
	Hex	Y = Enabled		When Hex Mode is enabled, any call data that is determined to be bad data will be output in Hex format. Only visible if ADEM 8000 or SK9000 format is selected.
		N = Disabled	✓	
	Heartbeat	Y = Enabled		See Section 5.3.3.5 for programming steps.
N = Disabled		✓		
Time (of Heartbeat)	10-600 seconds	45 sec	How often a supervisory signal (a heartbeat) is sent to the automation computer. See Section 5.3.3.5 for programming steps.	

Table 5–5: Communications Options and Description (cont'd)





Communications Menu	Choices	Options	Default	Comments		
Automation Cfg (continued)	Ack Timeout	1-120 seconds	4 sec	15 seconds or less in UL applications. See Section 5.3.3.5 for programming steps.		
	<Cfg>		Term=013 Head=010 Ack=006 Nack=021 Time Req=005 Time Head=084 Time Term=020	Only visible if ADEMCO 685, FBII220 or CAPS ONLY format is selected. Note: Setting Ack and Nack to 0 disables Ack and Nack.		
	Sep	Y = Enabled			Only visible if SK9000 format is selected. When enabled, a hex 05 is output for an account separator. When not selected, a hex 2E is output for an account separator.	
		N = Disabled		✓		
	<ITI>	Log Records			Only visible if ITI Gen or ITIComp format is selected.	
			✓			
		Enable External ID	Y = Enabled			
			N = Disabled			✓
		Super Char		s		
		No Data Char		0		
Generic Revision	6.1		✓			
	6.2					
Annunciator Cfg	Printer	Yes	✓	Yes = will annunciate on the receiver sounder if an event, trouble or fault condition occurs. No = no annunciation if an event, trouble or fault condition occurs. See Section 5.3.3.6 for programming steps. Device corresponds to loss of communication with slave or line card. Listen in must be set to No for UL installations.		
		No				
	Bkp Printer	Yes	✓			
		No				
	Auto Comp	Yes	✓			
		No				
	Bkp Auto Comp	Yes	✓			
		No				
	Battery	Yes	✓			
		No				
	Device	Yes	✓			
		No				
	Line Fault	Yes	✓			
		No				
	AC Power	Yes	✓			
		No				
	Buffer Full	Yes	✓			
		No				
Listen In	Yes	✓				
	No					
Call Pending	Yes	✓				
	No					

Table 5–5: Communications Options and Description (cont'd)

Communications Menu	Choices	Options	Default	Comments
Aux Relay Cfg	Printer	Yes	✓	Yes = will annunciate if an event, trouble or fault condition occurs.
		No		
	Bkp Printer	Yes	✓	
		No		
	Auto Comp	Yes	✓	Device corresponds to loss of communication with slave or line card.
		No		
	Bkp Auto Comp	Yes	✓	
		No		
	Battery	Yes	✓	
		No		
	Device	Yes	✓	
		No		
	Line Fault	Yes	✓	
		No		
	AC Power	Yes	✓	
		No		
	Buffer Full	Yes	✓	
		No		
Listen In	Yes	✓	Listen in must be set to No for UL installations.	
	No			
Call Pending	Yes	✓		
	No			

5.3.3.1 How to Set Up Port Function





Port functions set up how each of the communication ports will be used. Before you start to set up the port functions review the rules for port functions in Table 5–5.

1. Enter program mode. (See Section 5.1.)
2. Press **1** for general options.
3. Press **3** for communications.
4. Press **1** to set port functions.
5. Press the  or  button until the display flashes on the desired port setting.
6. Press .
7. Repeat steps 5 through 6 until all port functions are set.
8. Press  to exit menu.

5.3.3.2 How to set Com Port 1 Parameters





Set the baud rate, the number of data bits, number of stop bits, the parity, and the flow control (see Table 5–5 for choice details).

1. Enter program mode. (See Section 5.1.)
2. Press **1** for general options.
3. Press **3** for communications.

4. Press **2** to set Com Port1 parameters.
 5. Press the  or  button until the display flashes on the desired port setting.
 6. Press .
- Note:** See “How to Edit Init String (Com 1, Com 2, and Parallel Port)” in Section 5.3.3.4.
7. Repeat steps 5 through 6 until all parameters are set.
 8. Press  to exit menu.

5.3.3.3 How to Set Com Port 2 Parameters

Set the baud rate, the number of data bits, number of stop bits, the parity, and the flow control (see Table 5–5 for choice details).

1. Enter program mode. (See Section 5.1.)
 2. Press **1** for general options.
 3. Press **3** for communications.
 4. Press **3** to set Com Port 2 parameters.
 5. Press the  or  button until the display flashes on the desired port setting.
 6. Press .
- Note:** See “How to Edit Init String (Com 1, Com 2, and Parallel Port)” in Section 5.3.3.4.
7. Repeat steps 5 through 6 until all parameters are set.
 8. Press  to exit menu.

5.3.3.4 How to Edit Init String (Com 1, Com 2, and Parallel Port)

An initialization string can be used to customize the output to the device connected to a port on the receiver. For example, you can skip over perforations, set proportional spacing, or condense the print output to a printer. The display format for the init string is shown in Figure 5–7 and Table 5–6 lists the characters that can be entered into the string.

Note: Refer to the user manual of the device connected to the receiver for special command sequences.

Follow these steps to insert an initialization string:

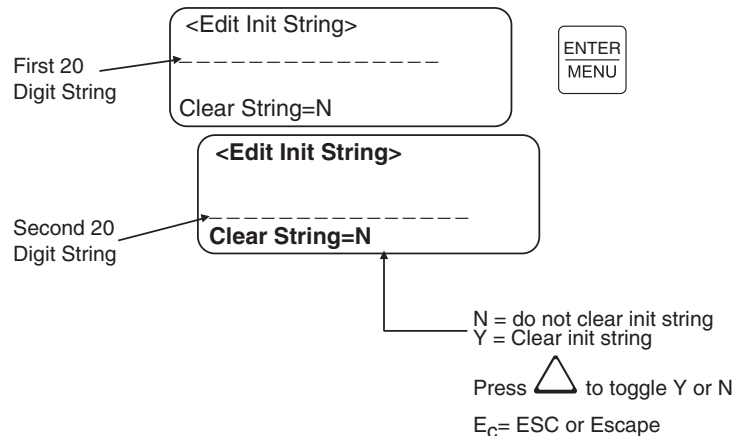

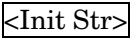





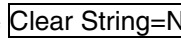



Figure 5–7: Initialization String Display

Table 5–6: Initialization String Characters

Character	Description
0-9	Numeric characters, which can be entered from the touchpad or up/down arrows.
a-z and A-Z	Alpha characters entered with the up/down arrows.
: _ - . , & * # ? ^E C and space bar.	Special Characters entered with the up/down arrows.

1. Press  at the flashing  field.
2. Press the  or  button until the desired character flashes.
3. Press , the next character position will flash.
4. Repeat steps 2 and 3 until the desired sequence is complete.
5. Press .
6. Repeat steps 2 through 5 for the second string.

To clear an init string:

1. At the  field, press  until the desired option flashes. See Figure 5–7.
2. Press .
3. Press  to exit menu.







5.3.3.5 How to Set Automation Communication

Through this option the automation communication format and parameters can be set up. (See Table 5–5 for format choices.)

Note: After the automation format has been defined or changed, the output may not be correct until the receiver has been reset.

How to Set the Format

Follow these steps to set the automation communication format.





1. Enter program mode. (See Section 5.1.)
2. Press  for general options.
3. Press  for communications.
4. Press  to setup automation configuration.
5. Press the  or  button until the display flashes on the desired port setting.
6. Press .
7. Press  if you wish to exit menu or continue with heartbeat.

How to Enable or Disable Hex Mode

When Hex Mode is enabled, any call data that is determined to be bad will output in a Hex format. This feature is only available if ADEM 8000 or SK9000 automation protocol is selected.

Note: This feature should be disabled if the automation software package that you are using does not recognize Hex data.





Follow these steps to enable or disable heartbeat:

1. Enter program mode. (See Section 5.1.)
2. Press for general options.
3. Press for communications.
4. Press to set up automation configuration.
5. Press  until the heartbeat field is flashing.
6. Press the  or  button until the display flashes on the desired setting.
7. Press .
8. If you wish to exit, press  until you exit this menu.

How to Enable or Disable Heartbeat

A heartbeat is a supervisory signal that continually tests the communication link between the automation computer and the receiver.

Follow these steps to enable or disable heartbeat:





1. Enter program mode. (See Section 5.1.)
2. Press for general options.
3. Press for communications.
4. Press to set up automation configuration.
5. Press  until the heartbeat field is flashing.
6. Press the  or  button until the display flashes on the desired setting.
7. Press .
8. If you wish to exit, press  until you exit this menu.

Time (Period of Heartbeat)

This option determines how often the heartbeat is sent to the automation computer. For example, if the time is set to 60 seconds (default setting) then a heartbeat will be sent every 60 seconds.

Follow these steps to set the time period or the heartbeat:





1. Enter program mode. (See Section 5.1.)
2. Press for general options.

3. Press **3** for communications.
4. Press **5** to set up automation configuration.
5. Press  until the time field is flashing.
6. From the number keypad enter the desired number or press the  or  button until the display flashes on the desired setting.
7. Press .
8. If you wish to exit, press  until you exit this menu.

Ack Time (Acknowledge Time)

The acknowledge time is the duration that the receiver will wait for a response from the automation computer after a data packet has been sent. Data packets include all reports and heartbeats.

Follow these steps to set the time period or the heartbeat:

1. Enter program mode. (See Section 5.1.)
2. Press **1** for general options.
3. Press **3** for communications.
4. Press **5** to set up automation configuration.
5. Press  until the ack time field is flashing.
6. From the number keypad enter the desired number or press the  or  button until the display flashes on the desired setting.
7. Press .
8. If you wish to exit, press  until you exit this menu.

ITI Options (Only Visible if ITI Gen or ITIComp Formats are Chosen)

These are options particular to the ITI automation format and can only be edited if one of these formats is used to communicate with the automation computer. See Sections 8.8 and 8.10.

Follow these steps to set the ITI options:







1. Enter program mode. (See Section 5.1.)
2. Press **1** for general options.
3. Press **3** for communications.
4. Press **5** to set up automation configuration.
5. Press  until the ack <ITI> field is flashing.
6. Press .

Table 5–7: ITI Automation Format Options





Option	Choices	Default	Meaning	Comments
Log Recs	Y (Yes)	N	Log records identify the time and date of an incoming report.	
	N (No)			
XID	Y (Yes)	N	Extended panel Identification code.	See 8.9.2.2.
	N (No)			
SupCh		s	Supervisory Character is sent from the automation computer. The receiver will respond with an OKAY or supervisory record. See Sections 8.9.5 and 8.10.5.	
No Data		0	Identifies the no data character in the log record.	

Note: ITI automation formats are covered in greater detail in Sections 8.8 and 8.10.



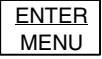

Log Recs (For ITI Formats):

1. At the flashing **Log Recs** field press the  or  button until the display flashes on the desired setting.
2. Press .
3. If you wish to exit, press  until you exit this menu.





XID (Extended ID for ITI Panels):

1. At the flashing **XID** field press the  or  button until the display flashes on the desired setting.
2. Press .
3. If you wish to exit, press  until you exit this menu.

SupCh (Supervisory Character):

1. At the flashing **SupCh [s]** field press the  or  button until the display flashes on the desired setting.
2. Press .
3. If you wish to exit, press  until you exit this menu.



NoData (No Data Character for Log Record):

1. At the flashing **NoData[0]** field enter a digit from 0-9 from the touchpad or press the  or  button until the display flashes on the desired setting.
2. Press .
3. If you wish to exit, press  until you exit this menu.

5.3.3.6 How to Configure the On-board Annunciator Outputs

Program what will give a trouble annunciation or what will not annunciate from the on-board annunciator.

1. Enter program mode. (See Section 5.1.)
2. Press  for general options.



3. Press **3** for communications.
4. Press **6** to set annunciator configuration.
A list of the annunciator output options appears.
5. Press the  or  button to move through the annunciator output options.
6. When the equal sign highlights the option you wish to change, press **ENTER MENU**.

Note: Additional presses of the enter button toggle the setting between “yes” or “no”. See Table 5–8.

7. Repeat steps 5 through 6 for all annunciator options you wish to change. See Table 5–8 for list of additional options.

5.3.3.7 How to Configure the Auxiliary Relay Outputs

Program what will give a trouble output to the auxiliary relay contact. (To program the normal state of the auxiliary relay, see Section 5.3.4.)

1. Enter program mode. (See Section 5.1.)
2. Press **1** for general options.
3. Press **3** for communications.
4. Press **7** to set relay configuration.
A list of the relay output options appears.
5. Press the  or  button to move through the relay output options.
6. When the equal sign highlights the option you wish to change, press **ENTER MENU**.

Note: Additional presses of the enter button toggle the setting between “yes” or “no”. See Table 5–8.

7. Repeat steps 5 through 6 for all relay options you wish to change. See Table 5–8 for list of additional options.

Table 5–8: On-board Annunciator and Auxiliary Relay Options

Option	Choices	Comments
Printer	Y (Yes)	Y = The on-board annunciator will beep if there is an error condition. N = No on-board annunciation if an error condition exist.
	N (No)	
Bkp Printer	Y (Yes)	
	N (No)	
Auto Comp	Y (Yes)	
	N (No)	
Bkp Auto Comp	Y (Yes)	
	N (No)	
Battery	Y (Yes)	
	N (No)	
Device	Y (Yes)	
	N (No)	
Line Fault	Y (Yes)	
	N (No)	
AC Power	Y (Yes)	
	N (No)	
Buffer Full	Y (Yes)	
	N (No)	
Listen In	Y (Yes)	
	N (No)	
Call Pending	Y (Yes)	
	N (No)	

5.3.4 System Options

In system options you can configure the backup battery configuration, the receiver ID number, and the normal state of the auxiliary relay.

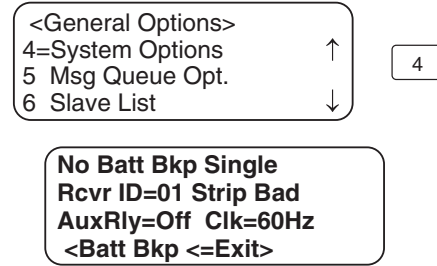

Figure 5–8: System Options Display

5.3.4.1 How to Change Backup Battery Setting

Through system options the backup battery can be configured for the type of backup battery your installation site requires.

1. Enter program mode. (See Section 5.1.)
2. Press 1 for general options.
3. Press 4 for system options.
4. Press the or button until the display flashes on the desired setting.
5. Press ENTER
MENU.

To Exit:





Press until you return to the main menu.

Table 5–9: System Options

System Options Menu	Choices	Default	Comments
Battery Backup Cfg	No Battery Bkp	✓	No charging current applied to battery circuit. Receiver will not test battery output or give trouble annunciations.
	Battery Bkp		Charging current applied to battery circuit.
	DC Bkp		No charging current applied to battery circuit. Typically used for systems that use a UPS (uninterrupted power supply) for backup battery power.
Receiver Mode	Single	✓	Receiver is operating independently.
	Slave		Receiver is a slave to a master receiver.
	Master		Receiver is a master.
Receiver ID	01-99	01	
Bad Data Blocks	Strip Bad	✓	If this is selected an indicator will be sent to the automation computer that indicates a bad data block was received.
	Send Bad		Same as Strip Bad except the bad data block is sent with the indicator.
Aux Relay Normal State	Off (De-energized)	✓	See Section 5.3.4.5 for auxiliary relay output options.
	On (Energized)		
Clock Source	60Hz	✓	Synchronize clock to 60Hz Line input.
	50Hz		Synchronize clock to 50Hz Line input.
	Int (Internal)		Synchronize clock to internal crystal.

5.3.4.2 How to Set the Receiver as a Single, Slave, or Master

In large central stations, it may be desired to set up receivers in a master/slave relationship for reporting to a printer. To set the receiver to act as a single receiver, master receiver, or slave receiver, proceed as follows:



1. Enter program mode. (See Section 5.1.)
2. Press **1** for general options.
3. Press **4** for system options.
4. Press .
The display will flash on the receiver mode: **Single**
5. Press the  or  button until the display flashes on the desired setting.
6. Press .

To Exit:

Press  until you return to the main menu.

5.3.4.3 How to Set the Receiver ID Number

In large central stations where calls may be coming in on several receivers at once, the automation software will need to identify which receiver it received a call from. This will help in troubleshooting if a problem occurred with the automation system or receiver.

1. Enter program mode. (See Section 5.1.)
 2. Press **1** for general options.
 3. Press **4** for system options.
 4. Press  .
- The display will flash on the receiver ID number: **Rcvr ID=01**
5. Enter the desired receiver ID number (a number from 01 to 99).

Note: If you are outputting to an automation computer using 685, CAPS, or CP-220 automation protocol, see Table 5-10 for valid entries for ID numbers 1-9 and A-Z.

6. Press .

To Exit:

Press  until you return to the main menu.

Table 5-10: 685, CAPS, and CP-220 1-9/A-Z Entries

Keypad Entry	Number/Letter	Keypad Entry	Number/Letter	Keypad Entry	Number/Letter	Keypad Entry	Number/Letter
01	1	65	A	74	J	83	S
02	2	66	B	75	K	84	T
03	3	67	C	76	L	85	U
04	4	68	D	77	M	86	V
05	5	69	E	78	N	87	W
06	6	70	F	79	O	88	X
07	7	71	G	80	P	89	Y
08	8	72	H	81	Q	90	Z
09	9	73	I	82	R		

5.3.4.4 How to Configure Output for Bad Data Blocks

This feature selects how bad data blocks will be sent from the receiver to the automation computer. If Strip Bad is selected then an indicator will be sent to the automation computer when a bad data block is received, but the actual bad data block will not be sent. If Send Bad is selected an indicator will be sent to the automation computer along with the bad data block.



1. Enter program mode. (See Section 5.1.)

2. Press for general options.

3. Press for system options.

4. Press    .

The display will flash on the Bad Data Blocks: **Strip_Bad**

5. Press the  or  button until the display flashes on the desired setting.

6. Press .

To Exit:

Press  until you return to the main menu.

5.3.4.5 How to Set the Normal State of the Auxiliary Relay Contact

The auxiliary relay contact is a Form C relay. This feature allows you to set the state of the auxiliary relay normally open contact when power is applied to the receiver.



1. Enter program mode. (See Section 5.1.)

2. Press for general options.

3. Press for system options.

4. Press     .

The display will flash on the auxiliary relay setting: **Aux Relay=Off**

5. Press the  or  button until the display flashes on the desired setting.

6. Press .

To Exit:

Press  until you return to the main menu.

5.3.4.6 How to Set Clock Synchronization Source

This feature allows you to set the synchronization source for the receiver's clock.



1. Enter program mode. (See Section 5.1.)

2. Press for general options.

3. Press for system options.

4. Press      .

The display will flash on the clock: **Clk=60Hz**

5. Press the  or  button until the display flashes on the desired setting.
6. Press .

To Exit:

Press  until you return to the main menu.

5.3.5 Message Queue Options

Set the percentage of how full the message queue must be before a “Message Queue Warning” and “Message Queue Warning Restore” occur. See Section 7 for trouble messages.

***Note:** The “Warning On” can be set from 10% to 99%; the “Warning Off” can be set from 1% to 90%. A minimum separation of 5% will be set between the On % and the Off %. For example, if the “Warning On” is set to 82% the “Warning Off” maximum setting can be 77%.*

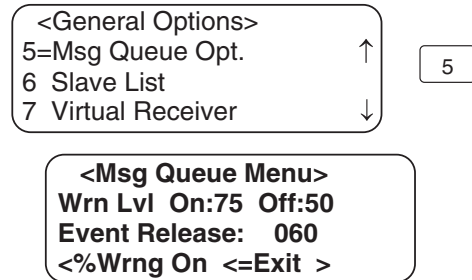





Figure 5-9: Message Queue Display

5.3.5.1 Set the Message Queue Warning On level

Set the percentage of how full the message queue can get before the receiver indicates a “Message Queue Warning” condition.





1. Enter program mode. (See Section 5.1.)
2. Press  for general options.
3. Press  for message queue options.
4. Enter the level (in %) you wish the receiver message queue to get before it will indicate a message queue warning.
5. Press .

To Exit:

Press  until you return to the main menu.

5.3.5.2 Set the Message Queue Warning Off Level

Set the percentage level where the receiver will indicate a restore condition for a “Message Queue Warning”.

1. Enter program mode. (See Section 5.1.)
2. Press  for general options.
3. Press  for message queue options.
4. Press  until the display flashes on the Off field.
5. Enter the level (in %) you wish the receiver message queue to get before it will indicate a message queue warning restore.
6. Press .

To Exit:

Press  until you return to the main menu.

5.3.5.3 Set the Event Release Time

Used to define the maximum amount of time (in seconds) that the receiver will hold an event in memory prior to sending it to automation, VFD, and printer. The time begins at the beginning of the call or on an acknowledgement.

Notes:

- If the Event Release setting is "greater" than the Call Hang-Up setting (see page5–48), the receiver will not disconnect the line (panel) until the Event Release time has expired.
- The actual amount of time before the receiver disconnects a line may at times be greater than the actual programmed value for Call Hang-Up Time. An event in progress (Event Release) has to complete before the call hang-up takes affect.

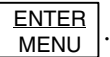
1. Enter program mode. (See Section 5.1.)
2. Press **1** for general options.
3. Press **5** for message queue options.
4. Press  until the display flashes on the Event Release field.
5. Enter the event release time (001 or 020 to 120) in seconds.
6. Press .

To Exit:

Press  until you return to the main menu.

5.3.6 Slave List



Through the slave list menu, you can add a slave receiver, view a slave, or delete a slave.

Notes:

- For this menu to be available, the receiver being programmed must be a master receiver as detailed in Section 5.3.4.2.
- The slave ID number must be different than the master receiver ID number and also must be different than any other slave receiver ID number that is reporting to the master receiver.

5.3.6.1 Add Slave

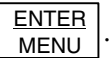
To add a slave to a master receiver:

1. Enter program mode. (See Section 5.1.)
2. Press **1** for general options.
3. Press **6** for slave list options.
4. Press **1** to select add slave.
5. The receiver will display the message: **Enter Slave #: 00**
6. Enter a 2-digit slave ID number.
7. Press .
8. To define a second slave receiver, enter second 2-digit slave ID number.
9. Press .

To Exit:

Press  until you return to the main menu.

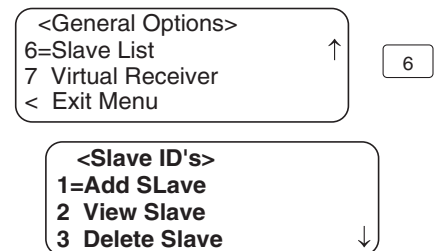



Figure 5–10: Slave List Display

5.3.6.2 View Slave

To view a slave to a master receiver:

1. Enter program mode. (See Section 5.1.)
2. Press **1** for general options.
3. Press **6** for slave list options.
4. Press **2** to select view slave.
5. The receiver will display a listing of slave receivers assigned.



To Exit:

Press  until you return to the main menu.

5.3.6.3 Delete Slave

To delete a slave from a master receiver:



1. Enter program mode. (See Section 5.1.)
2. Press **1** for general options.
3. Press **6** for slave list options.
4. Press **3** to select delete slave.
5. The receiver will display a listing of slave receivers assigned.

6. Select a receiver for deletion using the  or  keys.

7. Press **ENTER MENU**.

8. The receiver will display:

```
Snn 8000 Slave
Delete Record? No
```

9. Toggle the yes/no display using the  or  keys.

10. Press **ENTER MENU** with yes displayed to delete the receiver.

11. Repeat steps 4 through 10 to delete another receiver.

To Exit:

Press  until you return to the main menu.

5.3.7 Virtual Receiver/Line Numbers

The use of virtual receiver numbers allows multiple receiver numbers to be assigned in the same MX8000 or multiple MX8000s if operating in the master/slave configuration. Each virtual receiver number can have from 1 to 108 line(s) assigned to it.

The virtual receiver and line number(s) are used when displaying, printing, or sending data to the automation system. If desired, the same virtual line # can be assigned to more than one line in the same MX8000.

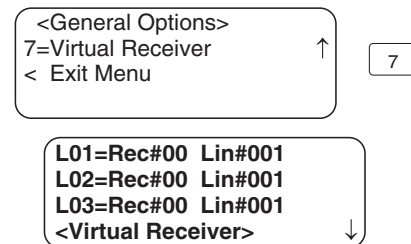

Figure 5–11: Virtual Receiver/Line Numbers Display

To assign virtual receiver and virtual line numbers:

Notes:

- If virtual receiver/line numbers are being used, DO NOT assign a hunt group number to a line. If a hunt group number is assigned, it takes precedence and the virtual number will not be used.
- Virtual receiver/line numbers will not be used when reporting an expander trouble. For an expander troubles, the actual receiver/line number will be used.

1. Enter program mode. (See Section 5.1.)
2. Press **1** for general options.
3. Press **7** for virtual receiver/line numbers.



The display will flash on the virtual receiver number of the first line in the receiver: **L01=Rec# 00**

Note: The display will list all physical lines in the receiver.

4. Enter the desired virtual receiver number (a number from 00 to 99).

Notes:

- If the virtual receiver number is programmed as zero for a given line then the system receiver number will be used for the line's receiver number and the line number will be the lines physical number.
- If you are outputting to an automation computer using 685, CAPS, or CP-220 automation protocol, see Table 5–10 on page 5–22 for valid entries for ID numbers 1–9 and A–Z.

5. Press  to advance to the virtual line number field.
6. Enter the desired virtual line number (a number from 001 to 036).
Note: For proper reporting to an automation computer, use 008 or less when using 685 or CAPS automation protocol or 015 or less if using CP-220 automation protocol.
7. Press **ENTER MENU** to accept the entry and advance to the next line or press  if the line contains an error that you need to correct.
8. Repeat steps 4 through 7 for each virtual receiver/line to be defined.

To Exit:

Press  until you return to the main menu.

5.4 Line Device Menu

Through the Line Device menu you can add a new Line Card and edit, clear, or view existing Line Devices.

Table 5–11 lists the menu options available under Line Device menu.

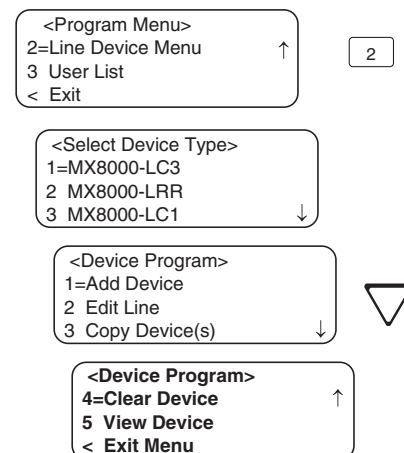

Figure 5–12: Choosing Line Device Menu and Line Device Program Menu Items

Table 5–11: Line Device Menu Options

Select Device Type	Line Device Menu	Choice	Choice	Choice	Choice	Default	Comments	
MX8000–LC3 3 Line	Add Device	Enter Device #	Use Defaults					
			Copy Existing					
	Edit Line	Line #		Handshake Sequence	Sequence Number	1	See the corresponding numbers below.	The order in which the Line will output different handshakes. For more information see page 5–38
						2		
						3		
						4		
						5		
						6		
					Format Group	1400_2300–2	1.	Number in default column indicates the default handshake sequence number. For more information see page 5–39
						1400Hz	2.	
						2300Hz	3.	
						2225Hz	4.	
						Modem II	5.	
						Modem IIE	6.	
						Westec		
						1400_2300Hz		
					Handshake Duration	0-9999 In 1ms periods	1. 100	For more information see page 5–39
							2. 1000	
							3. 1000	
							4. 0900	
5. 1000								
6. 1520								
Handshake Wait	0-9999 In 1ms periods	1. 1250	For more information see page 5–39					
		2. 3200						
		3. 3200						
		4. 3200						
		5. 3200						
		6. 3200						
Handshake Acknowledge Duration	0-9999 In 1ms periods	1. 0800	For more information see page 5–39					
		2. 1200						
		3. 1200						
		4. 0750						
		5. 0600						
		6. 0600						
Pulse Format	5-Digit Format	4/1	4/1	If a pulse comes in a 5-digit format then the data will then be treated as the selected format.				
		3/2						
	6-Digit Format	3/1CS (with checksum)	4/2					
		4/2						
	3/2CS (with checksum)	4/2	If a pulse comes in a 6-digit format then the data will then be treated as the selected format.					
	4/1CS (with checksum)							

Table 5–11: Line Device Menu Options (cont'd)

Select Device Type	Line Device Menu	Choice	Choice	Choice	Choice	Default	Comments	
MX8000–LC3 3 Line (cont'd)	Edit Line (cont'd)	Line # (cont'd)	Pulse Format (cont'd)	Inter-digit Tm (ms)	0 or 1 ms to 2 Sec.	0	This feature selects the time period between data blocks. See page 5–40 for more information.	
				Ack on Even Round	Yes or No	No	Select this option if the 1400 or 2300 Hz format requires an Ack tone on even rounds.	
				Partially Extended	Yes or No	Yes	Select this option if you have multiple extended data blocks for 3/ 1 or 4/1 formats.	
			Line Options	Direct	Y (Yes)			Y = dedicated or direct connect phone line. N = used for standard phone lines. See page 5–41 for more information.
					No (No)	✓		
				Number of Rings	0-255	002	If caller ID is turned on (see Section 5.4.2.5), rings should be set to 2. It is recommended that the number of rings is not set to a value greater than 5.	
				Country	USA CRT21	USA		
				Threshold	1-15 in 2.75 VDC steps	08 (22.0VDC)	See page 5–42 for more information.	
				Sample Time	00-99 seconds	08 (8 seconds)	See page 5–42 for more information.	
				Listen In	Listen Mode	Not Used	✓	See page 5–43 for more information. Must not be used in UL installations.
			Common					
			PBX			PBX String edit	See page 5–43 for more information.	
			Timeout		0-255	0	See page 5–44 for more information.	
			Listen In account edit		Add Account	None	See page 5–44 for more information.	
				Edit Account				
				Clear Account				
			Misc. Line Options	Echo Suppress	Y (Yes)		Outputs a 2 second 2025Hz tone to disable echo suppression equipment that may interfere with modem formats.	
					N (No)	✓		

Table 5–11: Line Device Menu Options (cont'd)

Select Device Type	Line Device Menu	Choice	Choice	Choice	Choice	Default	Comments
MX8000–LC3 3 Line (cont'd)	Edit Line (cont'd)	Line # (cont'd)	Misc. Line Options (cont'd)	Caller ID	Yes	✓	Caller ID to Automation: When enabled, Caller ID information is output to the automation system only in the event that no alarm data is received from a security system control panel. Caller ID to Printer Ports: When enabled, Caller ID information is output to the printer port(s) for every call received at the time that the Caller ID information is available from the Public Switched Telephone Network (normally between the first and second ring.) This option should only be used when connected to a parallel or serial printer or equivalent.
					No		
				Billing Delay	Y (Yes)		Initiates a 2-second delay at the start of each call before the handshake delay.
					N (No)	✓	
				Hunt Group	00-99	00	Allows multiple line cards to report under the same group number to the automation software.
				Ring Options	Min Ring (15-99)	40	See page 5–47 for more information.
					Max Ring (015-100)	060	
					Ring Off (1500-8000)	4000	
					Min Ring Off (100-800)	450	
					Ring Error (0800-4400)	2200	
Min # Ring Periods (01-20)	05						
Call Hang-up	60-180 sec	120 sec	Sets the maximum amount of time that a call can last before the receiver hangs up on the call if an event is not in progress. See page 5–48 for details.				

Table 5–11: Line Device Menu Options (cont'd)

Select Device Type	Line Device Menu	Choice	Choice	Choice	Choice	Default	Comments
MX8000– LC3 3 Line (cont'd)	Edit Line (cont'd)	Line # (cont'd)	Ademco Auto Opt	BFSK Auto	4/2		In High Speed, messages with event codes of B, C, E, and F are translated to ADEMCO High Speed messages.
					High Speed	✓	
				3/1 Restore	3/1	✓	Standard method: 123 2, 123 9
					High Speed		Converted to High Speed: 0123 5355 5555 7
				4/2 Out	Normal		In High Speed mode, messages with event codes of B and C are translated to High Speed Opening and Closing messages, respectively.
					High Speed	✓	
				FBI	S/Fast	✓	
					LAR300		
				Pulse Extended	Extended	✓	A sequence of 1234 B , BBBB 7 is combined into a 4-2 message of 1234 B7. (Applies to B,C,E,F). This message would either be put out to Automation as 4-2 or High Speed. When the option is selected, the receiver does not combine the expanded messages. They are output in the same form as received.
					Not Extended		
				Extended Output	High Speed	✓	If low speed expanded messages are received and combined (See Pulse Extended above), the messages are output to Automation as 4-2 format messages. For example, a sequence of 1234 B , BBBB 7 is combined and output as a 4-2 message of 1234 B7.
					4/2		
				Line Gain Opt	Transmit Gain	–3 through –6, –8, –10, –11, –12, or –14dB	–8db
Receive Gain	0 through 12dB in 3dB steps	6db					

Table 5–11: Line Device Menu Options (cont'd)

Select Device Type	Line Device Menu	Choice	Choice	Choice	Choice	Default	Comments	
MX8000–LC3 3 Line (cont'd)	Edit Line (cont'd)	Line # (cont'd)	Line Gain Opt (cont'd)	CID Monitor	Norm, Pream, DTMF, or Marks	Norm	Used to set Caller ID detection methods, gain, and impedance. See Section 5.4.2.7 for more information. These options are only used if Caller ID is enabled as described in Section 5.4.2.5.	
				CID Gain	–6, –2, 0, 2, 3.5, 4.8, 6, or 7dB	2dB		
				On Hook Gain	2, 3.5B, 4.8, 6, or 7dB	7dB		
				Ringer Impedance	Hi or Sy	Hi		
	Copy Device(s)	Use Default	Device #					Choose Device(s) # that you wish to be programmed to factory defaults.
		Copy Existing	Device # of Source & Target Device					Copy the program- ming of one Device (source) and paste it into one or several (target) Devices.
	Clear Device	Choose Device #						Deletes a Device from the receiver.
	View Device	Choose Device #						Views what Devices are installed.
	MX8000–LRR	Add Device	Device #	Use Defaults				
				Copy Existing				
Edit Line		Central Station #	000-255			017		
		Odd/Even Network	Odd/Even			Even		
		VPN	Yes/No			No		
		A/B Network	A/B			A		
		Monitor Station Flag	Yes/No			No		
Copy Device(s)		Use Default	Device #					Choose Device(s) # that you wish to be programmed to factory defaults.
		Copy Existing	Device # of Source & Target Device					Copy the programming of one Device (source) and paste it into one or several (target) Devices.
Clear Device(s)		Choose Device #					Deletes a Device from the receiver.	
View Device(s)		Choose Device #					Views what Devices are installed.	

Table 5–11: Line Device Menu Options (cont'd)

Select Device Type	Line Device Menu	Choice	Choice	Choice	Choice	Default	Comments	
MX8000–LC1 1 Line	Add Device	Device #	Use Defaults					
			Copy Existing					
	Edit Line	Line #	Handshake Sequence	Sequence Number	1	See the corresponding numbers below.		The order in which the device will output different handshakes. For more information see page 5–56.
					2			
					3			
					4			
					5			
					6			
				Format Group	1400_2300–2	1	Number in default column indicates the default handshake sequence number. For more information see page 5–56	
					1400Hz	2		
					2300Hz	3		
					2225Hz	4		
					Modem II	5		
					Modem IIE	6		
					Westec			
					1400_2300Hz			
			Handshake Delay	0-255 In 50ms periods	1. 002	(100ms)	For more information see page 5–56	
					2. 002	(100ms)		
					3. 002	(100ms)		
					4. 010	(500ms)		
					5. 002	(100ms)		
					6. 002	(100ms)		
			Handshake Duration	0-255 In 10ms periods	1. 010	(100ms)	For more information see page 5–57	
					2. 100	(1 sec)		
					3. 100	(1 sec)		
					4. 090	(900ms)		
					5. 100	(1 sec)		
					6. 152	(1.52 sec)		
Handshake Wait			0-255 In 50ms periods	1. 025	(1.25 sec)	For more information see page 5–39		
				2. 064	(3.2 sec)			
	3. 064	(3.2 sec)						
	4. 064	(3.2 sec)						
	5. 064	(3.2 sec)						
	6. 064	(3.2 sec)						
Handshake Acknowledge Duration	0-255 In 10ms periods	1. 055	(800ms)	For more information see page 5–57				
		2. 120	(1.2 sec)					
		3. 120	(1.2 sec)					
		4. 075	(750ms)					
		5. 060	(600ms)					
		6. 060	(600ms)					

Table 5–11: Line Device Menu Options (cont'd)

Select Device Type	Line Device Menu	Choice	Choice	Choice	Choice	Default	Comments
MX8000–LC1 1 Line (cont'd)	Edit Line (cont'd)	Line # (cont'd)	Pulse Format	5-Digit Format	4/1	4/1	If a pulse comes in a 5-digit format then the data will then be treated as the selected format.
					3/2		
					3/1CS (with checksum)		
				6-Digit Format	4/2	4/2	If a pulse comes in a 6-digit format then the data will then be treated as the selected format.
					3/2CS (with checksum)		
					4/1CS (with checksum)		
			Inter-digit Tm (ms)	0 or 1 ms to 2 Sec.	0	This feature selects the time period between data blocks. See page 5–58 for more information.	
			Ack on Even Round	Yes or No	No	Select this option if the 1400 or 2300 Hz format requires an Ack tone on even rounds.	
			Partially Extended	Yes or No	Yes	Select this option if you have multiple extended data blocks for 3/ 1 or 4/1 formats.	
			Line Options	Direct	Y (Yes)		Y = dedicated or direct connect phone line. N = used for standard phone lines. See page 5–59 for more information.
					No (No)	✓	
				Number of Rings	0-255	002	If caller ID is turned on (see Section 5.4.2.5), rings should be set to 2. It is recommended that the number of rings is not set to a value greater than 5.
				On time	1-255 in 50ms periods	010 (500ms)	See page 5–60 for more information.
				Off time	1-255 in 50ms periods	010 (500ms)	See page 5–60 for more information.
				dB Level	Lo (Low)		Select the dB level of the handshake and acknowledge tones.
					Hi (High)		
Md (Medium)	✓						
Threshold	1-15 in 2.0 VDC steps	08 (16.0VDC)	See page 5–60 for more information.				
Sample Time	0-255 seconds	020 (20 Sec)	See page 5–61 for more information.				

Table 5–11: Line Device Menu Options (cont'd)

Select Device Type	Line Device Menu	Choice	Choice	Choice	Choice	Default	Comments
MX8000– LC1 1 Line (cont'd)	Edit Line (cont'd)	Line # (cont'd)	Listen In	Listen Mode	Not Used	✓	See page 5–61 for more information. Must not be used in UL installations.
					Common		
					PBX	PBX String edit	See page 5–61 for more information.
				Timeout	0-255	0	See page 5–62 for more information.
				Listen In account edit	Add Account	None	See page 5–62 for more information.
			Edit Account				
			Clear Account				
			Misc. Line Options	Echo Suppress	Y (Yes)		Outputs a 2 second 2025Hz tone to disable echo suppression equipment that may interfere with modem formats.
					N (No)	✓	
				Caller ID	Yes	✓	Caller ID to Automation: When enabled, Caller ID information is output to the automation system only in the event that no alarm data is received from a security system control panel. Caller ID to Printer Ports: When enabled, Caller ID information is output to the printer port(s) for every call received at the time that the Caller ID information is available from the Public Switched Telephone Network (normally between the first and second ring.) This option should only be used when connected to a parallel or serial printer or equivalent.
					No		
				Billing Delay	Y (Yes)		Initiates a 2-second delay at the start of each call before the handshake delay.
					N (No)	✓	See page 5–64 for more information.
				Hunt Group	00-99	00	Allows multiple line cards to report under the same group number to the automation software.

Table 5–11: Line Device Menu Options (cont'd)

Select Device Type	Line Device Menu	Choice	Choice	Choice	Choice	Default	Comments	
MX8000–LC1 1 Line (cont'd)	Edit Line (cont'd)	Line # (cont'd)	Misc. Line Options (cont'd)	Call Hang-up	60-180 sec	120 sec	Sets the maximum amount of time that a call can last before the receiver hangs up on the call if an event is not in progress. See page 5–65 for details.	
			Ademco Auto Opt	BFSK Auto	4/2			In High Speed, messages with event codes of B, C, E, and F are translated to ADEMCO High Speed messages.
					High Speed	✓		
				3/1 Restore	3/1	✓		Standard method: 123 2, 123 9
					High Speed			Converted to High Speed: 0123 5355 5555 7
				4/2 Out	Normal			In High Speed mode, messages with event codes of B and C are translated to High Speed Opening and Closing messages, respectively.
					High Speed	✓		
			FBI	S/Fast	✓			
				LAR300				
			Pulse Extended	Extended	✓		A sequence of 1234 B , BBBB 7 is combined into a 4-2 message of 1234 B7. (Applies to B,C,E,F). This message would either be put out to Automation as 4-2 or High Speed. When the option is selected, the receiver does not combine the expanded messages. They are output in the same form as received.	
				Not Extended				
			Extended Output	High Speed	✓		If low speed expanded messages are received and combined (See Pulse Extended above), the messages are output to Automation as 4-2 format messages. For example, a sequence of 1234 B , BBBB 7 is combined and output as a 4-2 message of 1234 B7.	
4/2								

Table 5–11: Line Device Menu Options (cont'd)

Select Device Type	Line Device Menu	Choice	Choice	Choice	Choice	Default	Comments
MX8000–LC1 1 Line (cont'd)	Copy Device(s)	Use Defaults	Choose Device(s) #				Choose Device(s) # that you wish to be programmed to factory defaults.
		Copy Existing	Choose Device # of Source & Target Device				Copy the programming of one Device (source) and paste it into one or several (target) Devices.
	Clear Device	Choose Device #					Deletes a Device from the receiver.
	View Device	Choose Device #					Views what Devices are installed.

5.4.1 Add Line Device

To program in a new line device, follow these steps:

1. Install the new line device. (See Section 3.7.)
2. Log on to the receiver. (See Section 4.4.4 for log on procedure.)
3. Press button.

4. Press for program menu.

The display will briefly display

5. Press to choose Line Device menu.
6. Press , , or to select the device type.
7. Press to add the device.

The Display will show

8. Enter the slot number of the device being added (1-12).

9. Press button.

10. Choose to use defaults.

or

11. Press to use the programming of another Line.

5.4.2 Edit Line – MX8000–LC3 (3 Line)



To edit an existing Line, follow these steps:

1. Log on to the receiver. (See Section 4.4.4 for log on procedure.)
2. Press button.
3. Press for program menu.

The display will briefly display

4. Press **2** to choose Line Device menu.
5. Press **1** to select MX8000–LC3 (3 Line)
6. Press **2** to edit line.

The display will show a list of the existing Lines.

7. Press the  or  arrow buttons to move through the available list.
8. When the equal sign is on the Line you wish to edit:

Press .

The display will show a list of choices. Table 5–12 lists these choices and a brief description.

Table 5–12: MX8000–LC3 Edit Line List Items and Description

Edit Line List	Description
1 Handshake Seq	This function is used to program the handshake order and parameters for this Line.
2 Pulse Format	Used to set the 5- and 6-digit format, Interdigit timeout, acknowledgement, and to select if partially extended is enabled.
3 Line Options	Used to set number of rings, ring on/off duration, threshold voltage, and sample time.
4 Listen In	Used to program the parameters for the listen in (two-way voice communication) feature if used. Must not be used in UL installations.
5 Misc. Line Opt.	Used to program hunt group number, enable or disable echo suppression, and billing delay.
6 Ademco Auto Opt.	Used to select the BFSK auto output, 3/1 restore output, pulse output, and FBII output.
7 Line Gain Opt.	Used to select the transmit and receive line gain and some Caller ID gain options.

5.4.2.1 Handshake Sequence

Each line card is intelligent enough to determine what format is being sent from a reporting panel. You only need to program the handshake order and parameters for each Line. A Line will initiate up to six different types of handshake tone groups. The order in which the receiver sends out these handshake signals can be changed in this program location for each line card. Table 6–1 in Section 6 lists the proper handshake to use for the type of communication format you are using with a panel. Follow these steps to change the handshake order and or the parameters associated with the handshake.

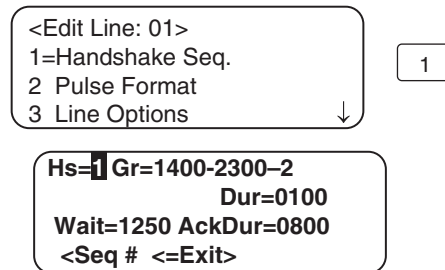





Figure 5–13: MX8000–LC3 Handshake Sequence Menu

To Change the Handshake Sequence Number:

Handshake sequence sets the order in which the receiver will send out handshakes.

1. Follow the procedures in Section 5.4.2.
2. Press **1** for handshake sequence menu.
When display flashes on the **Hs#** (see Figure 5–13).

3. Press the  or  button to change the ordered handshake number.
1 = the first handshake tone sent 2 = the second handshake tone to be sent and so on.

4. When the desired order number is flashing press  or .

The display will start flashing the format group field.

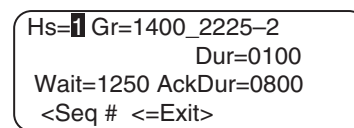









Figure 5–14: MX8000–LC3 Handshake Order Number

To Change the Format Group:

1. Follow the procedures in Section 5.4.2.
2. Press for handshake sequence menu.
3. Press  until the display flashes on the Format Group field. See Table 5–11 for valid entries.
4. Press the  or  button to change the format group. See Table 6–1 in Section 5 for your communication format.
5. When the desired format group is flashing press or .





To Change the Handshake Duration Time:

The handshake duration is the length of time that the receiver will send a handshake tone. See Table 5–11 for valid entries.

1. Follow the procedures in Section 5.4.2.
2. Press for handshake sequence menu.
3. Press  until the display flashes on the field.
4. Enter the desired value from the keypad or press the  or  button to change the handshake duration time.
5. When the desired handshake duration time is flashing press or .



To Change the Maximum Handshake Wait Time:

The wait time is the amount of time the receiver will wait for data from the reporting panel before outputting the next handshake sequence. See Table 5–11 for valid entries.

1. Follow the procedures in Section 5.4.2.
2. Press for handshake sequence menu.
3. Press  until the display flashes on the field.
4. Enter the desired value from the keypad or press the  or  button to change the wait time.
5. When the desired wait time is flashing press or .

To Change the Acknowledgment Tone Duration Time:



The acknowledgment tone duration time is the amount of time the receiver will send an acknowledgment tone to the reporting panel. See Table 5–11 for valid entries.

1. Follow the procedures in Section 5.4.2.
2. Press for handshake sequence menu.
3. Press  until the display flashes on the field.
4. Enter the desired value from the keypad or press the  or  button to change the acknowledgment tone duration time.





5.4.2.2 Pulse Format

Select how this line card will handle pulse formats that are outside the standards for pulse format protocol.

To Select Which Format a 5-digit Pulse Format will be received as:





1. Follow the procedures in Section 5.4.2.
2. Press for pulse format menu.
3. When the display flashes on the 5-digit Fmt field.
4. Select the format by pressing the  or  button.
5. When the desired wait time is flashing press or .

To Select Which Format a 6-digit Pulse Format will be received as:





1. Follow the procedures in Section 5.4.2.
2. Press for pulse format menu.
3. Press  until the display flashes on the 6-digit Pulse Fmt field.
4. Select the format by pressing the  or  button.
5. When the desired wait time is flashing press or .

To Select the Inter-Digit Time:





This option adjusts the time period between data blocks that the receiver will tolerate.

1. Follow the procedures in Section 5.4.2.
2. Press for pulse format menu.
3. Press  until the display flashes on the field.
Note: When the Timeout field is set to 0 (recommended), the MX8000 uses an algorithm to determine the inter-digit time. When set between 1 ms and 2000 ms, the time entered will be used.
4. Enter the desired value from the keypad or press the  or  button.
5. When the desired wait time is flashing press or .

Set for 2300 and 1400 formats that require Acknowledgements on Even Rounds:

1. Follow the procedures in Section 5.4.2.
2. Press for pulse format menu.
3. Press  until the display flashes on the field.
4. Select the format by pressing the  or  button.
5. When the desired wait time is flashing press or .

Set for 3/1 and 4/1 Partially Extended Formats:

1. Follow the procedures in Section 5.4.2.
2. Press **2** for pulse format menu.
3. Press  until the display flashes on the **Partially Ex** field.
4. Select the format by pressing the  or  button.
5. When the desired wait time is flashing press **ENTER MENU** or .

5.4.2.3 Line Options

Line options is used to set the type of phone line, number of rings, country, and threshold voltage.

Note: Setting the number of rings to 0 disables the line device.

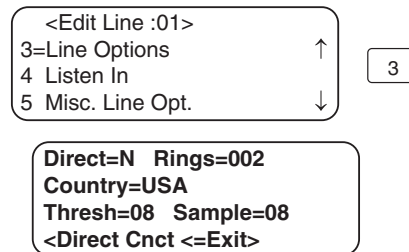





Figure 5–15: MX8000–LC3 Line Options Menu





How to Set the Line Card for a Direct Line (Dedicated Line):

Note: This option must only be chosen for panels that have a direct connect capability. The panel supplies all line bias and a PBX is not required. This options sets the line card for a dedicated mode where the line is dedicated to the panel and normal timeouts will not occur.

1. Follow the procedures in Section 5.4.2.
2. Press **3** for Line Options menu.
3. The display will flash on the **Direct** field.
4. Press the  or  button to between Y for Yes, or N for No.
5. When the desired setting is flashing press **ENTER MENU** or .

To Change the Number of Rings, Follow These Steps:

This controls the number of rings the line device needs to see before it will answer the call.





1. Follow the procedures in Section 5.4.2.
2. Press **3** for Line Options menu.
3. Press  until the display flashes on the **Rings** field.
4. Enter the desired value from the keypad (000-255) or press the  or  button to change the number of rings before the receiver will answer.
Note: Setting the number of rings to 0 disables the line device.
5. When the desired number of rings is flashing press **ENTER MENU** or .

Notes:

- It is recommended that the number of rings is not set to a value greater than 5.
- If Caller ID (see Section 5.4.2.5) is turned on the number of rings must be set to 2.





To Change Country:

The “Country” field selects USA or CRT21.

1. Follow the procedures in Section 5.4.2.
2. Press **3** for Line Options menu.
3. Press  until the display flashes on the **Country** field.
4. Press the  or  button to change the Country. Values are USA or CRT21.
5. When the desired selection is flashing press  or .





To Change the Ring Threshold Voltage:

The “Threshold” field controls the phone line low voltage/Line Fault threshold level. If the voltage on the phone line connected to the line card drops below this set threshold level for that Device, the receiver will indicate a **Line Fault** on that phone line.

1. Follow the procedures in Section 5.4.2.
2. Press **3** for Line Options menu.
3. Press  until the display flashes on the **Thresh** field.
4. Enter the desired value from the keypad or press the  or  button to change the Line fault threshold level. Values range from 1 to 15 volts in 2.75 VDC increments (1=2.75VDC, 2=5.5VDC, 3=8.25VDC and so on).
5. When the desired line fault threshold is flashing press  or .

To Change the Phone Line Sample Rate:

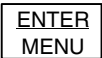
The sample field controls how often the receiver will sample the phone line to verify that it is above the set threshold level of that line card. This is how often the receiver verifies the integrity of the phone line.

1. Follow the procedures in Section 5.4.2.
2. Press **3** for Line Options menu.
3. Press  until the display flashes on the **Sample** field.
4. Enter the desired value from the keypad or press the  or  button to change the line sample rate. Values range from 00 to 90 in 1 second increments (0=Line monitor disabled, 1=1 second, 2=2 seconds, 3=3 seconds and so on). The receiver will make two to three samples before generating a trouble condition on a faulty line.
5. When the desired sample time is flashing press  or .
6. Press  to exit this menu.



5.4.2.4 Listen-In

The listen in feature is used to perform two-way voice alarm verification between the central station and the alarm installation site.

Note: See Section 4.7 on page 4–19 for a description of the listen-in modes.

To Change the Listen Mode:

1. Follow the procedures in Section 5.4.2.
2. Press **4** for the listen in options menu.
3. When the display shows the listen in options menu (see Figure 5–16):



Press the  or  button to change the listen mode setting.

4. When the desired setting is flashing press **ENTER MENU**.

To Change the PBX String:

This option only appears if PBX is selected as the mode.

1. Follow the procedures in Section 5.4.2.
2. Press **4** for Listen In options menu.
3. Press  until the display flashes on the **<Str>** field.
4. Press **ENTER MENU**.

5. Enter the desired numeric value from the keypad or press the  or  button to enter any special characters.

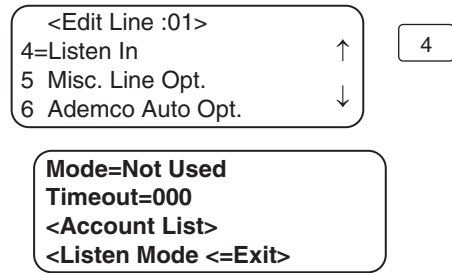





Figure 5–16: MX8000–LC3 Listen Mode Menu Display

Table 5–13: Valid Programmable String Characters

Character	Description
F	Flash hook.
P	Delay 500ms
,	Delay 2 seconds
H	Force a hang up of the line.
@	Detect dial tone.
t	Check to see if the line is busy by looking for a busy tone.
0-9, *, #, A, B, C, D	DTMF digits.

6. Press  to move to the next character.
or

7. Press **ENTER MENU** to enter the PBX string.

8. Select Y or N by pressing the  or  arrows.



Y = Yes, erase or clear the PBX string. N = No, do not clear the PBX string, save the entered value.

Note: If Yes is selected the PBX string will be cleared and the “Clear String” option will revert to N (No).

To Change the Listen-In Timeout:

Timeout is the amount of time Listen-in will remain active before timing out.

Note: This setting will only have an affect if using the common mode. When using the PBX mode, the call is transferred to another number and the line card drops the call.

1. Follow the procedures in Section 5.4.2.
2. Press **4** for Listen In options menu.
3. Press  until the display flashes on the **<Timeout>** field.
4. Enter the desired value from the keypad or press the  or  button to change the timeout setting. Values range from 0 to 255 in 1 second increments.
5. When the desired value is flashing press **ENTER MENU**.

To Edit the Listen-In Accounts Lists:

Note: The accounts lists apply to panels that do not send listen-in commands as a part of their message (Contact ID E606 or SIA LF and LE). Panels that send listen-in commands as part of their message do not need their account number in an account list.

1. Follow the procedures in Section 5.4.2.
2. Press **4** for Listen In options menu.
3. Press  until the display flashes on the **<Account List>** field.
4. Press **ENTER MENU**.

Figure 5-17 shows the next display.

To Add a Listen-In Account

Note: Panels that send listen-in commands (Contact ID E606 or SIA LF and LE) as part of their message do not need their account number in an account list.

1. Press **1**.

The display briefly shows the number (indicated by **XX**) of the lowest available listen in account number slot (20 total listen in account numbers [strings]). **Adding # XX**

Note: The account numbers may contain wild card entries (* and #) described in Table 5-14. Therefore, the 20 account numbers are actually up to 20 unique strings.

2. Enter the account number you wish to add to the listen in account list.
3. When the desired account number is flashing press **ENTER MENU**.

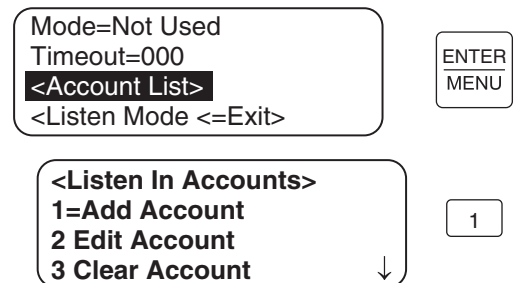



Figure 5-17: MX8000-LC3 Listen In Accounts Menu

Table 5-14: Account Characters



Characters	Description
0-9	Numeric entries
A-Z	Alpha entries
*	Alphanumeric wild card entry. Example: 123* = any account starting with 123.
#	Numeric wild card entry. Example: # = 0 to 9. Example: 12345# = 123450 to 123459.

To Edit a Listen-In Account

1. Press **2**.
2. Press the  or  button until the desired listen in account is highlighted by the equal sign.
3. Press **ENTER MENU**.
4. Enter the revised account number you wish to the account list. See Table 5–14.
5. Press **ENTER MENU**.

Note: When editing an existing account it must be completely re-entered.

To Clear a Listen-In Account

1. Press **3**.
2. Press the  or  button until the desired listen in account is highlighted by the equal sign.
3. Press **ENTER MENU**.

The Display will read: **< WARNING! >
Delete Record No**

4. Press the  or  button to toggle to Yes.

Note: Additional presses of the up or down arrow will toggle the choice between “yes” and “no”.

5. Press **ENTER MENU**.

5.4.2.5 Misc. Line Opt.

Some phone lines may use echo suppression, a billing delay feature, a hunt group or you may need to set various ring options. These miscellaneous phone options can be set through this programming menu.

```
<Edit Line :01>
5 Misc. Line Opt.      ↑
6 Ademco Auto Opt.
7 Line Gain Opt.
```



5

```
Echo Spr=N Call ID=Y
BillDly=N HntGrp=00
<Ring Opt> HngUp=120
<Echo Suppress<=Exit>
```

Figure 5–18: MX8000–LC3 Miscellaneous Phone Line Options

To Change the Echo Suppress Setting:

If echo suppression is enabled (Y) a 2025Hz signal will be output for two seconds to disable echo suppression equipment. This option should be used only for panels that require a 2225Hz handshake.



1. Follow the procedures in Section 5.4.2.
2. Press **5** for Miscellaneous Line Options menu (see Figure 5–18).
The display Flashes on the **Echo Spr=** field.
3. Press the  or  button to change the echo suppress option from Y (Yes) to N (No) or vice versa.
4. When the setting is flashing press **ENTER MENU**.

How to Set Caller ID

Caller ID information is only sent if the incoming call has no data contained in it.



Notes: *Caller ID to Automation* – When enabled, Caller ID information is output to the automation system only in the event that no alarm data is received from a security system control panel.

Caller ID to Printer Ports – When enabled, Caller ID information is output to the printer port(s) for every call received at the time that the Caller ID information is available from the Public Switched Telephone Network (normally between the first and second ring.) This option should only be used when connected to a parallel or serial printer or equivalent.

1. Follow the procedures in Section 5.4.2.
2. Press **5** for Miscellaneous Line Options menu (see Figure 5–18).
The display Flashes on the **Echo Spr=** field.
3. Press  until the display flashes on the **Call ID** field.
4. Press the  or  button to change the caller ID option from Y (Yes) to N (No) or vice versa.
5. When the setting is flashing press **ENTER MENU**.



To Change the Billing Delay Setting:

If billing delay is enabled (Y), a delay of two seconds will be inserted at the beginning of each incoming call.

1. Follow the procedures in Section 5.4.2.
2. Press **5** for Miscellaneous Line Options menu.
3. Press  until the display flashes on the **BillIDly** field.
4. Press the  or  button to toggle the billing delay between “Yes” or “No”.
5. When the desired setting is flashing press **ENTER MENU**.

To Change the Hunt Group:

Note: *If a Hunt Group number is assigned to a line that has a virtual line number assigned, the Hunt Group Number will take precedence and the virtual line and receiver numbers will be ignored.*

1. Follow the procedures in Section 5.4.2.
2. Press **5** for Miscellaneous Line Options menu.
3. Press  until the display flashes on the **HntGrp** field.
4. Enter the desired value from the keypad or press the  or  button to change the hunt group number.

Notes:

- *If using the ADEMCO 685 or ADEMCO 685 CAPS Automation Protocol, valid entries are 00 through 08.*
- *If using the CP-220 Automation Protocol, valid entries are 00 through 09 or 65 (A) through 70 (F). Keypad entries for A through F are provided in Table 5–10 on page 5–22.*

5. When the desired hunt group is flashing press .

6. To exit press .

To Change the Ring Options:

Note: The default ring options will function for most installations and will not need to be changed.

The ring options menu items (Figure 5–19) have the following meanings:

MinR (Minimum Ring Period) – This value is the minimum ringer frequency that is accepted as a valid. A valid ring frequency must fall between the Minimum Ring Period and the Maximum Ring Period.

Max (Maximum Ring Period) – This value is the maximum ringer frequency that is accepted as a valid. A valid ring frequency must fall between the Minimum Ring Period and the Maximum Ring Period.







ROff (Ringer Off Time) – This value is the normal amount of time between rings on the local phone system. If the value entered in this field is too large for your local phone system, it may cause the system to miss the beginning of Caller ID information.

Min (Minimum Ringer Off Time) – Caller ID information is normally sent between the first and second ring. On some phone systems the first ring is sent in 2 bursts with a short pause in between. For proper handling of caller ID the system needs to be able to determine that these 2 bursts are one ring. The Minimum Ringer Off Time is used to determine what the minimum interval is between rings so that the system will treat two burst separated by a brief pause as one ring.

RErr (Ringer Off Error) – To determine when a new call is received, the system will add the value of ROff, Min, and this value. When the length of time since the last ring exceeds this sum, the ring will be considered as a new call. This field is used to enter the amount of time to be added to ROff and Min when determining if a ring is a new call.

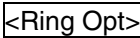
Min# (Minimum Number of Ringer Periods) – This field is used to define the number of valid rings that must be received before the system accepts the call as valid (answers).

To Change the Ring Options:

- Follow the procedures in Section 5.4.2.
- Press  for Miscellaneous Line Options menu.
- Press  until the display flashes on the  field.
- Press .
- The display flashes on the Minimum Ring Period (MinR) field.
- Enter a value from 15 to 99 ms for the Minimum Ring Period.
- Press  to advance to the Max Ring Period (Max) field.
- Enter a value from 015 to 100 ms for the Maximum Ring Period.
- Press  to advance to the Ringer Off Time (ROff) field.
- Enter a value from 1500 to 8000 ms for the Ringer Off Time.

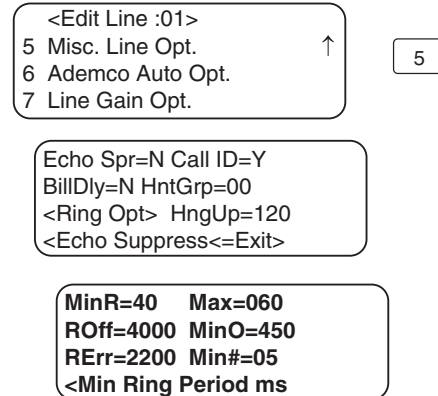











Figure 5–19: MX8000–LC3 Ring Options

11. Press  to advance to the Min Ring Off (Min) field.
12. Enter a value from 100 to 800 ms for the Minimum Ring Off Time.
13. Press  to advance to the Ringer Off Error (RErr) field.
14. Enter a value from 0800 to 4400 ms for the Ringer Off Error Time.
15. Press  to advance to the Min # of Ring Periods (Min#) field.
16. Enter a value from 01 to 20 periods for the Minimum Number of Ringer Periods.
17. To exit press  .

To Change the Call Hang-Up Time:

Notes:

- If the Event Release setting (see page 5–25) is "greater" than the Call Hang-Up setting, the receiver will not disconnect the line (panel) until the Event Release time has expired.
- The actual amount of time before the receiver disconnects a line may at times be greater than the actual programmed value for Call Hang-Up Time. An event in progress (Event Release) has to complete before the call hang-up takes affect.

1. Follow the procedures in Section 5.4.2.
2. Press 5 for Miscellaneous Line Options menu.
3. Press  until the display flashes on the HngUp field.
4. Enter the desired value from the keypad or press the  or  button to change the number of seconds.
5. When the desired number of seconds is flashing press ENTER
MENU.
6. To exit press .

5.4.2.6 Ademco Auto Opt.

This selection is used to select the BFSK Auto output of Hi Speed or 4/2, the 3/1 Restore output of Hi Speed or 3/1, the 4/2 Out Automation Conversion of codes 9, B, C, D, E, and F of Hi Speed or Normal, combining 3/1 and 4/1 expanded messages (Pulse Extended), Extended Output format, and the FBII output of FBII Super Fast or FBII LAR300.

How to Set BFSK Auto Output

1. Follow the procedures in Section 5.4.2.
2. Press 6 for Ademco Auto Opt. menu (see Figure 5–20).

The display Flashes on the BFSK= field.

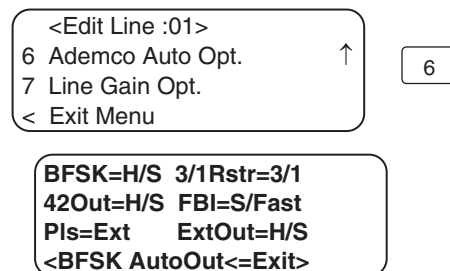

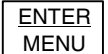

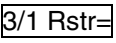







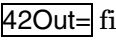



Figure 5–20: MX8000–LC3 ADEMCO Auto Output Options

3. Press the  or  button to change the option from HiSpeed to 4/2 or vice versa.
4. When the desired setting is flashing press .









How to Set 3/1 Restore Output

1. Follow the procedures in Section 5.4.2.
2. Press  for Ademco Auto Opt. menu (see Figure 5–20).
3. Press the  button.
The display Flashes on the  field.
4. Press the  or  button to change the option from HiSpeed to 3/1 or vice versa.
5. When the desired setting is flashing press .

How to Set 4/2 Out







1. Follow the procedures in Section 5.4.2.
2. Press  for Ademco Auto Opt. menu (see Figure 5–20).
3. Press  .
The display Flashes on the  field.
4. Press the  or  button to change the option from HiSpeed to Normal or vice versa.
5. When the desired setting is flashing press .
6. To exit press .

How to Set FBI Out

1. Follow the procedures in Section 5.4.2.
2. Press  for Ademco Auto Opt. menu (see Figure 5–20).
3. Press   .
The display Flashes on the  field.
4. Press the  or  button to change the option from S/Fast to LAR300 or vice versa.
5. When the desired setting is flashing press .
6. To exit press .









How to Set Pulse Extended

1. Follow the procedures in Section 5.4.2.
2. Press  for Ademco Auto Opt. menu (see Figure 5–20).

3. Press    .
The display Flashes on the **Pls=** field.
4. Press the  or  button to change the option from Extended to Not Extended or vice versa.
5. When the desired setting is flashing press  .
6. To exit press  .

How to Set Extended Output

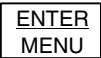



Note: This field will only be active when the Pulse Extended option above has been set to Extended.

1. Follow the procedures in Section 5.4.2.
2. Press  for Ademco Auto Opt. menu (see Figure 5–20).
3. Press    .
The display Flashes on the **ExtOut=** field.
4. Press the  or  button to change the option from High Speed to 4/2 or vice versa.
5. When the desired setting is flashing press  .
6. To exit press  .

5.4.2.7 Line Gain Opt.

This selection is used to select the gain for transmit and receive for a line.

How to Set Transmit Gain

1. Follow the procedures in Section 5.4.2.
2. Press  for Line Gain Opt. menu (see Figure 5–21).
The display Flashes on the **Xmit=** field.
3. Press the  or  button to change the transmit gain.
4. When the desired setting is flashing press  .

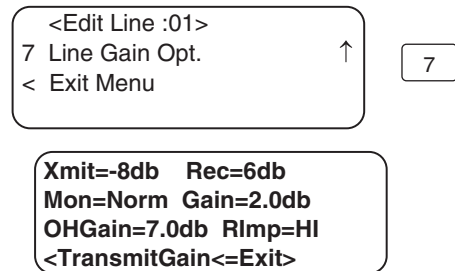







Figure 5–21: MX8000–LC3 Line Gain Options

How to Set Receive Line Gain

1. Follow the procedures in Section 5.4.2.
2. Press  for Line Gain Opt. menu (see Figure 5–21).
3. Press the  button.
The display Flashes on the **Rec=** field.
4. Press the  or  button to change the receive gain.

5. When the desired setting is flashing press .

6. To exit press .



How to Set CID Monitor

Caller ID Monitor allows the selection of different modes for decoding Caller ID. These are:

- *Normal* (or standard) where the detection method is first ring, delay, preamble, marks, and then Caller ID data.
- *Preamble* where the Caller ID chip looks for preamble data prior to Caller ID.
- *DTMF* where the system looks for DTMF based Caller ID data. (This is a non-standard method of Caller ID.
- *Marks* where the Caller ID chip looks for a Marks signal prior to the Caller ID data.

Note: This option is will only be applicable when Caller ID has been selected.

1. Follow the procedures in Section 5.4.2.
2. Press  for Line Gain Opt. menu (see Figure 5–21).

3. Press the   .
The display Flashes on the  field.

4. Press the  or  button to change the CID monitor.

5. When the desired setting is flashing press .





6. To exit press .

How to Set CID Gain

Caller ID gain sets the gain of the Caller ID receive logic.

Note: This option is will only be applicable when Caller ID has been selected.

1. Follow the procedures in Section 5.4.2.
2. Press  for Line Gain Opt. menu (see Figure 5–21).

3. Press the    .
The display Flashes on the  field.

4. Press the  or  button to change the CID Gain.

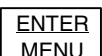



5. When the desired setting is flashing press .

6. To exit press .

How to Set On Hook Gain

On hook gain sets the analog receive Caller ID gain prior to line pickup.





Note: This option is will only be applicable when Caller ID has been selected.

1. Follow the procedures in Section 5.4.2.
2. Press **7** for Line Gain Opt. menu (see Figure 5–21).
3. Press the .
The display Flashes on the **OHGain=** field.
4. Press the  or  button to change the On Hook Gain.
5. When the desired setting is flashing press **ENTER MENU**.
6. To exit press .

How to Set Ringer Impedance

Ringer Impedance allows the impedance the Caller ID chip presents to the phone line to be set for either High or Synthesize.



Note: This option is will only be applicable when Caller ID has been selected.

1. Follow the procedures in Section 5.4.2.
2. Press **7** for Line Gain Opt. menu (see Figure 5–21).
3. Press the .
The display Flashes on the **RImp=** field.
4. Press the  or  button to change the Ringer Impedance.
5. When the desired setting is flashing press **ENTER MENU**.
6. To exit press .

5.4.3 Edit Line – MX8000–LRR

To edit an existing Line, follow these steps:

1. Log on to the receiver. (See Section 4.4.4 for log on procedure.)
2. Press **ENTER MENU** button.
3. Press **7** for program menu.
The display will briefly display **Initializing Please wait . . .**
4. Press **2** to choose Line Device menu.
5. Press **2** to select MX8000–LRR.

6. Press **2** to edit Line.
The display will show a list of the existing Lines.
7. Press the  or  arrow buttons to move through the available list.
8. When the equal sign highlights the Line you wish to edit:

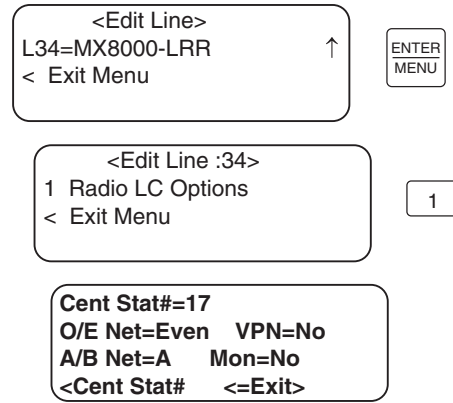







Figure 5–22: MX8000–LRR Line Edit

9. Press **1** to select Radio LC Options.
An edit screen is displayed that allows the Central Station number to be changed, Odd/Even Parity, Virtual Private, and A/B networks to be defined, and monitor stations to be enabled.



How to Set Central Station # (LRR Receiver ID)

1. Follow the procedures in Section 5.4.2.7.
The display Flashes on the **Cent Stat#=** field.
2. Press the  or  button to change the number or enter the number from the keypad. The number can be from 001 to 255.
Note: A central station number supplied by AlarmNet is in hexadecimal format. Use Table 5–15 on page 5–54 to convert the hexadecimal AlarmNet number into the decimal number that is entered into the MX8000.
3. When the desired number is flashing press **ENTER MENU**.

How to Set Odd/Even Network



1. Follow the procedures in Section 5.4.2.7.
2. Press the  button.
The display Flashes on the **O/E Net=** field.
3. Press the  or  button to change the option from Odd to Even or vice versa.
4. When the desired setting is flashing press **ENTER MENU**.

How to Set VPN (Virtual Private Network)

1. Follow the procedures in Section 5.4.2.7.
2. Press  .
The display Flashes on the **VPN=** field.

Notes:

- When using the VPN feature with ADEMCO 8000 automation protocol, the LRR card must be installed in slot 12.
- When using the VPN feature with 685 or CAPS automation protocol and NOT using Virtual Receiver / Line numbers, the LRR card must be installed in slot 3 (see page 1–6).
- When using the VPN feature with 685 or CAPS automation protocol and WITH Virtual Receiver / Line numbers, assign the card as line 8.

3. Press the  or  button to change the option from No to Yes or vice versa.
4. When the desired setting is flashing press



ENTER MENU

.



Table 5–15: Hexadecimal AlarmNet Number to Decimal Conversion

HEX	DEC	HEX	DEC	HEX	DEC	HEX	DEC	HEX	DEC	HEX	DEC	HEX	DEC	HEX	DEC
1	1	21	33	41	65	61	97	80	128	A0	160	C0	192	E0	224
2	2	22	34	42	66	62	98	81	129	A1	161	C1	193	E1	225
3	3	23	35	43	67	63	99	82	130	A2	162	C2	194	E2	226
4	4	24	36	44	68	64	100	83	131	A3	163	C3	195	E3	227
5	5	25	37	45	69	65	101	84	132	A4	164	C4	196	E4	228
6	6	26	38	46	70	66	102	85	133	A5	165	C5	197	E5	229
7	7	27	39	47	71	67	103	86	134	A6	166	C6	198	E6	230
8	8	28	40	48	72	68	104	87	135	A7	167	C7	199	E7	231
9	9	29	41	49	73	69	105	88	136	A8	168	C8	200	E8	232
A	10	2A	42	4A	74	6A	106	89	137	A9	169	C9	201	E9	233
B	11	2B	43	4B	75	6B	107	8A	138	AA	170	CA	202	EA	234
C	12	2C	44	4C	76	6C	108	8B	139	AB	171	CB	203	EB	235
D	13	2D	45	4D	77	6D	109	8C	140	AC	172	CC	204	EC	236
E	14	2E	46	4E	78	6E	110	8D	141	AD	173	CD	205	ED	237
F	15	2F	47	4F	79	6F	111	8E	142	AE	174	CE	206	EE	238
10	16	30	48	50	80	70	112	8F	143	AF	175	CF	207	EF	239
11	17	31	49	51	81	71	113	90	144	B0	176	D0	208	F0	240
12	18	32	50	52	82	72	114	91	145	B1	177	D1	209	F1	241
13	19	33	51	53	83	73	115	92	146	B2	178	D2	210	F2	242
14	20	34	52	54	84	74	116	93	147	B3	179	D3	211	F3	243
15	21	35	53	55	85	75	117	94	148	B4	180	D4	212	F4	244
16	22	36	54	56	86	76	118	95	149	B5	181	D5	213	F5	245
17	23	37	55	57	87	77	119	96	150	B6	182	D6	214	F6	246
18	24	38	56	58	88	78	120	97	151	B7	183	D7	215	F7	247
19	25	39	57	59	89	79	121	98	152	B8	184	D8	216	F8	248
1A	26	3A	58	5A	90	7A	122	99	153	B9	185	D9	217	F9	249
1B	27	3B	59	5B	91	7B	123	9A	154	BA	186	DA	218	FA	250
1C	28	3C	60	5C	92	7C	124	9B	155	BB	187	DB	219	FB	251
1D	29	3D	61	5D	93	7D	125	9C	156	BC	188	DC	220	FC	252
1E	30	3E	62	5E	94	7E	126	9D	157	BD	189	DD	221	FD	253
1F	31	3F	63	5F	95	7F	127	9E	158	BE	190	DE	222	FE	254
20	32	40	64	60	96	80	128	9F	159	BF	191	DF	223	FF	255

How to Set A/B Network

1. Follow the procedures in Section 5.4.2.7.
2. Press    .
The display Flashes on the

A/B Net=

 field.
3. Press the  or  button to change the option from A to B or vice versa.
4. When the desired setting is flashing press

ENTER MENU

.

How to Set Monitor Station

1. Follow the procedures in Section 5.4.2.7.

2. Press .

The display Flashes on the **Mon=** field.

3. Press the  or  button to change the option from Yes to No or vice versa.

4. When the desired setting is flashing press .

5. To exit press .

5.4.4 Edit Line – MX8000–LC1 (1 Line)

To edit an existing Line Device, follow these steps:

1. Log on to the receiver. (See Section 4.4.4 for log on procedure.)

2. Press  button.

3. Press  for program menu.

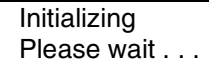
The display will briefly display .

4. Press  to choose Line Device menu.

5. Press  to select MX8000–LC1 (1 Line)

6. Press  to edit Line.

The display will show a list of the existing Lines.

7. Press the  or  arrow buttons to move through the available list.

8. When the equal sign is on the Line you wish to edit:

Press . The display will show a list of choices. Table 5–16 lists these choices and provides a brief description.

Table 5–16: MX8000–LC1 Edit Line List Items and Description

Edit Line List	Description
1 Handshake Seq	This function is used to program the handshake order and parameters for this Line.
2 Pulse Format	Used to set the 5- and 6-digit format, Interdigit timeout, acknowledgement, and to select if partially extended is enabled.
3 Line Options	Used to set number of rings, ring on/off duration, threshold voltage, and sample time.
4 Listen In	Used to program the parameters for the listen in (two-way voice communication) feature if used. Must not be used in UL installations.
5 Misc. Line Opt.	Used to program hunt group number, enable or disable echo suppression, and billing delay.
6 Ademco Auto Opt	Used to select the BFSK auto output, 3/1 restore output, pulse output, and FBII output.

5.4.4.1 Handshake Sequence

Each line card is intelligent enough to determine what format is being sent from a reporting panel. You only need to program the handshake order and parameters for each line. A line will initiate up to six different types of handshake tone groups. The order in which the receiver sends out these handshake signals can be changed in this program location for each line card. Table 6–1 in Section 6 lists the proper handshake to use for the type of communication format you are using with a panel.

Follow these steps to change the handshake order and or the parameters associated with the handshake.

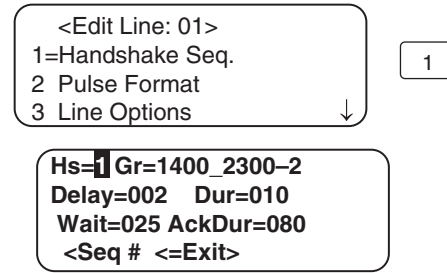

Figure 5–23: MX8000–LC1 Handshake Sequence Menu

To Change the Handshake Sequence Number:

Handshake sequence sets the order in which the receiver will send out handshakes.

1. Follow the procedures in Section 5.4.4.

2. Press **1** for handshake sequence menu.

When display flashes on the **Hs#** (see Figure 5–23).

3. Press the  or  button to change the ordered handshake number.

1 = the first handshake tone sent 2 = the second handshake tone to be sent and so on.

4. When the desired order number is flashing press **ENTER MENU** or .

The display will start flashing the format group field.

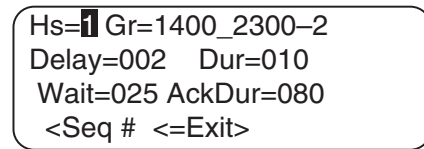





Figure 5–24: MX8000–LC1 Handshake Order Number

To Change the Format Group:

1. Follow the procedures in Section 5.4.4.

2. Press **1** for handshake sequence menu.

3. Press  until the display flashes on the Format Group field. See Table 5–11 for valid entries.

4. Press the  or  button to change the format group. See Table 6–1 in Section 6 for your communication format.

5. When the desired format group is flashing press **ENTER MENU** or .





To Change the Handshake Delay Time:

This is the duration of time that the receiver will wait before it sends its handshake tone. See Table 5–11 for valid entries.

1. Follow the procedures in Section 5.4.4.







2. Press **1** for handshake sequence menu.

3. Press  until the display flashes on the **Delay** field.

4. Enter the desired value from the keypad or press the  or  button to change the delay time.
5. When the desired handshake delay time is flashing press  or .







To Change the Handshake Duration Time:

The handshake duration is the length of time that the receiver will send a handshake tone. See Table 5–11 for valid entries.

1. Follow the procedures in Section 5.4.4.
2. Press  for handshake sequence menu.
3. Press  until the display flashes on the  field.
4. Enter the desired value from the keypad or press the  or  button to change the handshake duration time.
5. When the desired handshake duration time is flashing press  or .





To Change the Maximum Handshake Wait Time:

The wait time is the amount of time the receiver will wait for data from the reporting panel before outputting the next handshake sequence. See Table 5–11 for valid entries.

1. Follow the procedures in Section 5.4.4.
2. Press  for handshake sequence menu.
3. Press  until the display flashes on the  field.
4. Enter the desired value from the keypad or press the  or  button to change the wait time.
5. When the desired wait time is flashing press  or .

To Change the Acknowledgment Tone Duration Time:





The acknowledgment tone duration time is the amount of time the receiver will send an acknowledgment tone to the reporting panel. See Table 5–11 for valid entries.

1. Follow the procedures in Section 5.4.4.
2. Press  for handshake sequence menu.
3. Press  until the display flashes on the  field.
4. Enter the desired value from the keypad or press the  or  button to change the acknowledgment tone duration time.





5.4.4.2 Pulse Format

Select how this line card will handle pulse formats that are outside the standards for pulse format protocol.

To Select Which Format a 5-digit Pulse Format will be received as:





1. Follow the procedures in Section 5.4.4.
2. Press for pulse format menu.
3. Press  until the display flashes on the 5-digit Fmt field.
4. Select the format by pressing the  or  button.
5. When the desired wait time is flashing press or .

To Select Which Format a 6-digit Pulse Format will be received as:





1. Follow the procedures in Section 5.4.4.
2. Press for pulse format menu.
3. Press  until the display flashes on the 6-digit Pulse Fmt field.
4. Select the format by pressing the  or  button.
5. When the desired wait time is flashing press or .

To Select the Inter-Digit Time:





This option adjusts the time period between data blocks that the receiver will tolerate.

1. Follow the procedures in Section 5.4.4.
2. Press for pulse format menu.
3. Press  until the display flashes on the field.
Note: When the Timeout field is set to 0 (recommended), the MX8000 uses an algorithm to determine the inter-digit time. When set between 1 ms and 2000 ms, the time entered will be used.
4. Enter the desired value from the keypad or press the  or  button.
5. When the desired wait time is flashing press or .

Set for 2300 and 1400 formats that require Acknowledgements on Even Rounds:

1. Follow the procedures in Section 5.4.4.
2. Press for pulse format menu.
3. Press  until the display flashes on the field.
4. Select the format by pressing the  or  button.
5. When the desired wait time is flashing press or .

Set for 3/1 and 4/1 Partially Extended Formats:

1. Follow the procedures in Section 5.4.4.
2. Press **2** for pulse format menu.
3. Press  until the display flashes on the **Part Ex** field.
4. Select the format by pressing the  or  button.
5. When the desired wait time is flashing press **ENTER MENU** or .

5.4.4.3 Line Options

Line options is used to set the type of phone line, number of ring, ring on/off duration, threshold voltage, and sample time.

Note: Setting the number of rings to 0 disables the line device.

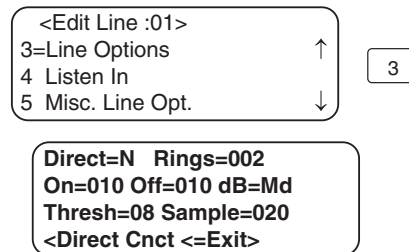





Figure 5–25: MX8000–LC1 Line Options Menu



How to Set the Line Card for a Direct Line (Dedicated Line):

Note: This option must only be chosen for panels that have a direct connect capability. The panel supplies all line bias and a PBX is not required. This options sets the line card for a dedicated mode where the line is dedicated to the panel and normal timeouts will not occur.

1. Follow the procedures in Section 5.4.4.
2. Press **3** for Line Options menu.
3. The display will flash on the **Direct** field.
4. Press the  or  button to between Y for Yes, or N for No.
5. When the desired setting is flashing press **ENTER MENU** or .

To Change the Number of Rings, Follow These Steps:

This controls the number of rings the receiver needs to see before it will answer the call.

1. Follow the procedures in Section 5.4.4.
2. Press **3** for Line Options menu.
3. The display will flash on the **Rings** field.
4. Enter the desired value from the keypad (000-255) or press the  or  button to change the number of rings before the receiver will answer.

Note: Setting the number of rings to 0 disables the line device.





5. When the desired number of rings is flashing press **ENTER MENU** or .

Notes:

- It is recommended that the number of rings is not set to a value greater than 5.
- If Caller ID (see Section 5.4.4.5) is turned on the number of rings must be set to 2.





To Change the Ring On Time:

The “On” field controls the ring on time. The ring on time is the length of time the receiver will listen to a ring prior to recognizing it as a ring.

1. Follow the procedures in Section 5.4.4.
2. Press **3** for Line Options menu.
3. Press  until the display flashes on the **On** field.
4. Enter the desired value from the keypad or press the  or  button to change the ring on time. Values range from 0 to 255 in increments of 50ms (1=50ms, 2=100ms, 3=150ms and so on).
5. When the desired ring on time is flashing press  or .





To Change the Ring Off Time:

The “Off” field controls the ring off time. The ring off time is the length of time the receiver will recognize an “Off” ring voltage.

1. Follow the procedures in Section 5.4.4.
2. Press **3** for Line Options menu.
3. Press  until the display flashes on the **Off** field.
4. Enter the desired value from the keypad or press the  or  button to change the ring off time. Values range from 0 to 255 in increments of 50ms (1=50ms, 2=100ms, 3=150ms and so on).
5. When the desired ring off time is flashing press  or .

To Select the dB Level:





This option selects the dB level of the handshake and acknowledge tone of the Line Device being programmed.

1. Follow the procedures in Section 5.4.4.
2. Press **3** for Line Options menu.
3. Press  until the display flashes on the **dB** field.
4. Press the  or  button to change the dB level of the handshake and acknowledge tone. Lo (Low) = -11dBm, Md (Medium) = -10dBm, Hi (High) = -9dBm.
5. When the setting is flashing press  or .

To Change the Ring Threshold Voltage:







The “Threshold” field controls the phone line low voltage/Line Fault threshold level. If the voltage on the phone line connected to the line card drops below this set threshold level for that Line Device, the receiver will indicate a **Line Fault** on that phone line.

1. Follow the procedures in Section 5.4.4.
2. Press **3** for Line Options menu.

3. Press  until the display flashes on the **Thresh** field.
4. Enter the desired value from the keypad or press the  or  button to change the Line fault threshold level. Values range from 1 to 15 volts in 2.0 VDC increments (1=2.0VDC, 2=4.0VDC, 3=6.0VDC and so on).
5. When the desired line fault threshold is flashing press  or .

To Change the Phone Line Sample Rate:

The sample time field controls how often the receiver will sample the phone line to verify that it is above the set threshold level of that line card. This is how often the receiver verifies the integrity of the phone line.

1. Follow the procedures in Section 5.4.4.
2. Press  for Line Options menu.
3. Press  until the display flashes on the **Sample** field.
4. Enter the desired value from the keypad or press the  or  button to change the line sample rate. Values range from 0 to 255 in 1 second increments (0=Line monitor disabled, 1=1 second, 2=2 seconds, 3=3 seconds and so on). The receiver will make two to three samples before generating a trouble condition on a faulty line.
5. When the desired sample time is flashing press  or .
6. Press  to exit this menu.



5.4.4.4 Listen-In

The listen in feature is used to perform two-way voice alarm verification between the central station and the alarm installation site.

Note: See Section 4.7 on page 4–19 for a description of the listen-in modes.

To Change the Listen Mode:

1. Follow the procedures in Section 5.4.4.
2. Press  for the listen in options menu.
3. When the display shows the listen in options menu (see Figure 5–26):

Press the  or  button to change the listen mode setting.

4. When the desired setting is flashing press .

To Change the PBX String:

This option only appears if PBX is select as the mode.

1. Follow the procedures in Section 5.4.4.
2. Press  for Listen In options menu.

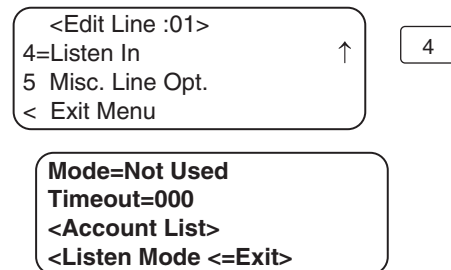













Figure 5–26: MX8000–LC1 Listen Mode Menu Display

3. Press  until the display flashes on the **<Str>** field.
4. Press .
5. Enter the desired numeric value from the keypad or press the  or  button to enter any special characters. (See Table 5-13, page 5-43 for valid programmable string characters.)
6. Press  to move to the next character.
or
7. Press  to enter the PBX string.
8. Select Y or N by pressing the  or  arrows.
Y = Yes, erase or clear the PBX string. N = No, do not clear the PBX string, save the entered value.
Note: If Yes is selected the PBX string will be cleared and the “Clear String” option will revert to N (No).

To Change the Listen-In Timeout:

Timeout is the amount of time Listen-in will remain active before timing out.

Note: This setting will only have an affect if using the common mode. When using the PBX mode, the call is transferred to another number and the line card drops the call.

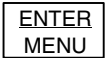
1. Follow the procedures in Section 5.4.4.
2. Press  for Listen In options menu.
3. Press  until the display flashes on the **<Timeout>** field.
4. Enter the desired value from the keypad or press the  or  button to change the timeout setting. Values range from 0 to 255 in 1 second increments.
5. When the desired value is flashing press .

To Edit the Listen-In Accounts Lists:

Note: The accounts lists apply to panels that do not send listen-in commands as a part of their message (Contact ID E606 or SIA LF and LE). Panels that send listen-in commands as part of their message do not need their account number in an account list.



1. Follow the procedures in Section 5.4.4.
2. Press  for Listen In options menu.
3. Press  until the display flashes on the **<Account List>** field.
4. Press .

Figure 5-27 shows the next display.

To Add a Listen-In Account

Note: Panels that send listen-in commands (Contact ID E606 or SIA LF and LE) as part of their message do not need their account number in an account list.

1. Press .

The display briefly shows the number (indicated by

Note: The account numbers may contain wild card entries (* and #) described in Table 5–14. Therefore, the 20 account numbers are actually up to 20 unique strings.

2. Enter the account number you wish to add to the listen in account list.
3. When the desired account number is flashing press .

```
Mode=Not Used
Timeout=000
<Account List>
<Listen Mode <=Exit>
```

```
<Listen In Accounts>
1=Add Account
2 Edit Account
3 Clear Account
```

Figure 5–27: MX8000–LC1 Listen In Accounts Menu

To Edit a Listen-In Account

1. Press .
2. Press the or button until the desired listen in account is highlighted by the equal sign.
3. Press .
4. Enter the revised account number you wish to the account list. See Table 5–14 on page 5–44.
5. Press .

Note: When editing an existing account it must be completely re-entered.

To Clear a Listen-In Account

1. Press .
2. Press the or button until the desired listen in account is highlighted by the equal sign.
3. Press .

The Display will read:

4. Press the or button to toggle to Yes.

Note: Additional presses of the up or down arrow will toggle the choice between “yes” and “no”.

5. Press .

5.4.4.5 Misc. Line Opt.

Some phone lines may use echo suppression, a billing delay feature, a hunt group or you may need to set various ring options. These miscellaneous phone options can be set through this programming menu.

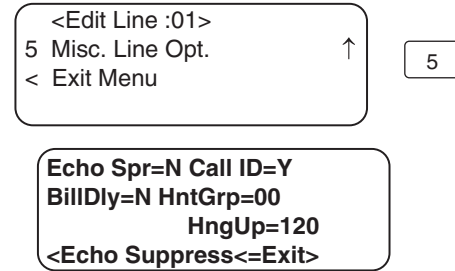



Figure 5–28: MX8000–LC1 Miscellaneous Phone Line Options

To Change the Echo Suppress Setting:

If echo suppression is enabled (Y) a 2025Hz signal will be output for two seconds to disable echo suppression equipment. This option should be used only for panels that require a 2225Hz handshake.

1. Follow the procedures in Section 5.4.4.
2. Press **5** for Miscellaneous Line Options menu (see Figure 5–28).

The display Flashes on the **Echo Spr=** field.

3. Press the  or  button to change the echo suppress option from Y (Yes) to N (No) or vice versa.
4. When the setting is flashing press **ENTER MENU**.

How to Set Caller ID



Caller ID information is only sent if the incoming call has no data contained in it.

Notes: *Caller ID to Automation – When enabled, Caller ID information is output to the automation system only in the event that no alarm data is received from a security system control panel.*

Caller ID to Printer Ports – When enabled, Caller ID information is output to the printer port(s) for every call received at the time that the Caller ID information is available from the Public Switched Telephone Network (normally between the first and second ring.) This option should only be used when connected to a parallel or serial printer or equivalent.

1. Follow the procedures in Section 5.4.4.
2. Press **5** for Miscellaneous Line Options menu (see Figure 5–28).





The display Flashes on the **Echo Spr=** field.

3. Press  until the display flashes on the **Call ID** field.
4. Press the  or  button to change the caller ID option from Y (Yes) to N (No) or vice versa.
5. When the setting is flashing press **ENTER MENU**.

To Change the Billing Delay Setting:





If billing delay is enabled (Y), a delay of two seconds will be inserted at the beginning of each incoming call.

1. Follow the procedures in Section 5.4.4.
2. Press **5** for Miscellaneous Line Options menu.

3. Press  until the display flashes on the **BillDly** field.
4. Press the  or  button to toggle the billing delay between “Yes” or “No”.
5. When the desired setting is flashing press .



To Change the Hunt Group:

Note: If a Hunt Group number is assigned to a line that has a virtual line number assigned, the Hunt Group Number will take precedence and the virtual line and receiver numbers will be ignored.

1. Follow the procedures in Section 5.4.4.
2. Press  for Miscellaneous Line Options menu.
3. Press  until the display flashes on the **HntGrp** field.
4. Enter the desired value from the keypad or press the  or  button to change the hunt group number.

Notes:







- If using the ADEMCO 685 Automation Protocol, valid entries are 00 through 08.
- If using the CP-220 Automation Protocol, valid entries are 00 through 09 or 66 (B) through 70 (F). Keypad entries for B through F are provided in Table 5–10 on page 5–22.

5. When the desired hunt group is flashing press .
6. To exit press .

To Change the Call Hang-Up Time:

Notes:

- If the Event Release setting (see page 5–25) is “greater” than the Call Hang-Up setting, the receiver will not disconnect the line (panel) until the Event Release time has expired.
- The actual amount of time before the receiver disconnects a line may at times be greater than the actual programmed value for C Hang-Up Time. An event in progress (Event Release) has to complete before the call hang-up takes affect.

1. Follow the procedures in Section 5.4.2.
2. Press  for Miscellaneous Line Options menu.
3. Press  until the display flashes on the **HngUp** field.
4. Enter the desired value from the keypad or press the  or  button to change the number of seconds.
5. When the desired number of seconds is flashing press .
6. To exit press .



5.4.4.6 Ademco Auto Opt.

This selection is used to select the BFSK Auto output of Hi Speed or 4/2, the 3/1 Restore output of Hi Speed or 3/1, the 4/2 Out Automation Conversion of codes 9, B, C, D, E, and F of Hi Speed or Normal, combining 3/1 and 4/1 expanded messages (Pulse Extended), Extended Output format, and the FBII output of FBII Super Fast or FBII LAR300.

How to Set BFSK Auto Output

1. Follow the procedures in Section 5.4.4.
2. Press **6** for Ademco Auto Opt. menu (see Figure 5–29).



The display Flashes on the **BFSK=** field.

3. Press the  or  button to change the option from HiSpeed to 4/2 or vice versa.
4. When the desired setting is flashing press **ENTER MENU**.

How to Set 3/1 Restore Output



1. Follow the procedures in Section 5.4.4.
2. Press **6** for Ademco Auto Opt. menu (see Figure 5–29).



3. Press the  button.
The display Flashes on the **3/1 Rstr=** field.

4. Press the  or  button to change the option from HiSpeed to 3/1 or vice versa.
5. When the desired setting is flashing press **ENTER MENU**.

How to Set 4/2 Out

1. Follow the procedures in Section 5.4.4.
2. Press **6** for Ademco Auto Opt. menu (see Figure 5–29).



3. Press   .
The display Flashes on the **42Out=** field.

4. Press the  or  button to change the option from HiSpeed to Normal or vice versa.
5. When the desired setting is flashing press **ENTER MENU**.

6. To exit press .

How to Set FBII Out

1. Follow the procedures in Section 5.4.4.
2. Press **6** for Ademco Auto Opt. menu (see Figure 5–29).

3. Press    .
The display Flashes on the **FBI=** field.

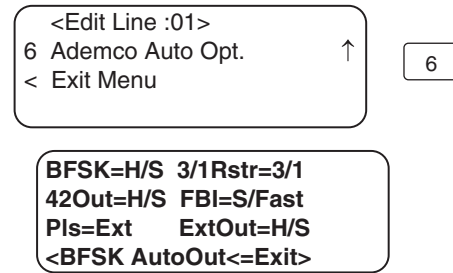

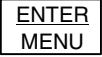











Figure 5–29: MX8000–LC1 ADEMCO Auto Output Options









4. Press the  or  button to change the option from S/Fast to LAR300 or vice versa.
5. When the desired setting is flashing press .
6. To exit press .

How to Set Pulse Extended

1. Follow the procedures in Section 5.4.2.
2. Press  for Ademco Auto Opt. menu (see Figure 5–29).
3. Press    .
The display Flashes on the  field.
4. Press the  or  button to change the option from Extended to Not Extended or vice versa.
5. When the desired setting is flashing press .
6. To exit press .

How to Set Extended Output

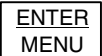



Note: This field will only be active when the Pulse Extended option above has been set to Extended.







1. Follow the procedures in Section 5.4.2.
2. Press  for Ademco Auto Opt. menu (see Figure 5–29).
3. Press    .
The display Flashes on the  field.
4. Press the  or  button to change the option from High Speed to 4/2 or vice versa.
5. When the desired setting is flashing press .
6. To exit press .

5.4.5 Copy Device(s)

Copy Device(s) allows you to either program a line to defaults or copy the programming of an existing line.

5.4.5.1 To Program the Default Settings Into a Device

1. Enter Program Mode (see section 5.1).
2. Press  for Line Device menu.
3. Press  (MX8000–LC3),  (MX8000–LRR), or  (MX8000–LC1) to select your line card type.
4. Press  for copy Line Device menu.















5. Press the  or  button until the equal sign is adjacent to the **Use Defaults** option. See Table 5-11 for description.
6. Press .
7. Press the  or  button until the equal sign highlights the desired Device number.
8. Press the  or  button to toggle between Y (yes) or N (no). Yes means you wish to program this device back to default.

When all the device numbers (of the devices you wish to program to factory defaults) are chosen.

Warning: *The following step cannot be undone.*

9. Press .

5.4.5.2 Copy the Programming of an Existing Device to Another

1. Enter Program Mode (see section 5.1).
2. Press  for Line Device menu.
3. Press  (MX8000-LC3),  (MX8000-LRR), or  (MX8000-LC1) to select your line card type.
4. Press  for copy Line Device menu.
5. Press the  or  button until the equal sign is adjacent the **Copy Existing** option. See Table 5-11 for description.
6. Press .
7. Press the  or  button until the equal sign highlights the desired Source Device number.
8. Press .
9. Press the  or  button until the equal sign highlights the desired Target Device number.
10. Press the  or  button to toggle between Y (yes) and N (no). Yes means you wish to program this line device with the programming of the line device chosen as the source.
11. Repeat steps 8 & 9 until all the line card numbers (of the Lines you wish to program to factory defaults) are chosen.

Warning: *The following step cannot be undone.*

12. Press .

5.4.6 Clear Device

To Clear or Delete a Device From the Receiver Follow These Steps:

1. Enter Program Mode (see section 5.1).
2. Press **2** for Line Device menu.
3. Press **1** (MX8000–LC3), **2** (MX8000–LC3), or **3** (MX8000–LC3) to select your line card type.
4. Press **4** to clear a Device.
5. When display shows the list of Devices (see Figure 5–30)



press the  until the desired Line is highlighted with an equal sign.

Note: The MX8000–LC3 shown in Figure 5–30 is an example only. The display will contain the number of the line card you are clearing.

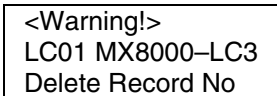
6. Press .

The display will read 

Note: The MX8000–LC3 shown above is an example only. The display will contain the number of the line card you are clearing.

7. Press the  until Yes is flashing.
8. Press .
9. To exit press .

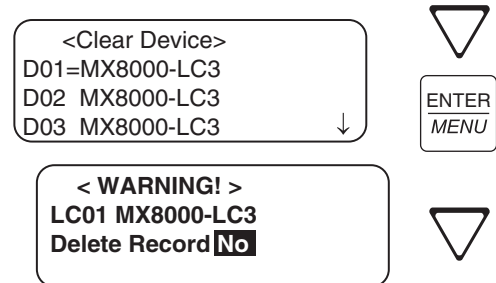



Figure 5–30: Visual Steps to Clear a Line From the Receiver

5.4.7 View Devices

To view all the Lines in the receiver follow these steps:

1. Enter Program Mode (see section 5.1).
2. Press **2** for Line Device menu.
3. Press **1** (MX8000–LC3), **2** (MX8000–LRR), or **3** (MX8000–LC1) to select your line card type.
4. Press **5** to view Devices.
5. When display shows the list of Devices (see Figure 5–30) press the  to scroll through the list of Devices.
6. To exit press .

5.5 User List

User List is used to program and store the information on the various installers and operators who will operate and maintain the receiver. Through this program menu item you can add, edit or clear (delete) an operator/installer (up to 40 users). The user is identified by name, and then assigned a PIN (personal identification number) and a profile.

Table 5–17 lists the available choices under User List and provides a matrix of choices.

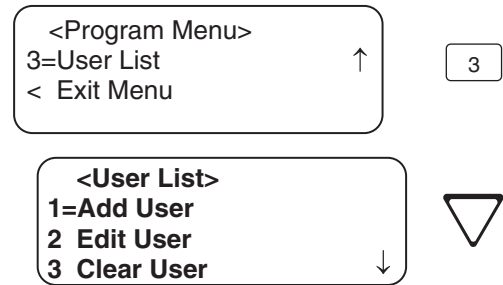

Figure 5–31: User List Menu Items

Table 5–17: User List Menu Items and Steps

Choice	Step 1	Step 2	Step 3	Comments
Add User	Enter user name: 1. Use the up or down arrow to move through characters. 2. Press the right arrow to move to next character slot. 3. Press enter key to move to next step.	Enter PIN code: 4 digits minimum 9 digits maximum	Choose profile level: Operator or Installer	Add user is used to add a new user to the system and enter the user's PIN and profile information.
Edit User	When "Choose User" list appears: 1. Press the down arrow key until the desired user is highlighted with the equal sign. 2. Press enter to move to next step.	Repeat Steps 1-3 under Add User.		Edit user is used to change an existing users profile.
Clear User	When "Choose User" list appears: 1. Press the down arrow key until the desired user is highlighted with the equal sign. 2. Press enter to move to clear user from profile list.			Clear user is used to delete a user from the receiver's memory.

5.5.1 Adding a User

Use the following steps to add a user to the system:

1. Log on to the receiver. (See Section 4.4.4 for log on procedure.)

2. Press  button.

3. Press  for program menu.

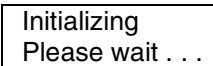
The display will briefly display .

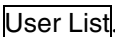
4. Press  to choose .

5. Press  to add a user.

The user number to be programmed will appear in the display for one second. This user number will always be the lowest available user number.



6. Press the  or  arrow buttons to move through the available characters.



Table 5–18: Available Characters

Characters	Comments
Space, 0-9, :, -, _, ., ,, &, *, #	The word “Space” indicates that a physical space would be inserted if this character were chosen.
A-Z	Upper case alphabetical characters
a-z	Lower case alphabetical characters

There are 16 characters available for each user name.



Note: If no characters are entered in the name field, the user name will default to “User #XX”. XX = the number location of the user being programmed. For example, if user 12 location is being programmed and no name characters are entered in the name field, then that user will be named User #12.

When the desired character is flashing in the display:

7. Press the  right arrow key.
8. Repeat steps 6 and 7 until the user’s name is complete.
9. Press .
10. Enter the desired PIN code for the user.
A minimum of 4 characters and a maximum of 9 characters.

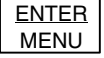

11. Press .

The display will flash Operator.





12. Press the  or  arrow buttons to toggle between Installer and Operator.
13. When the desired profile level is flashing press .

5.5.2 Editing a User

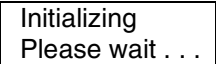

Use the following steps to edit an existing user:

1. Log on to the receiver. (See Section 4.4.4 for log on procedure.)
2. Press  button.
3. Press  for program menu.

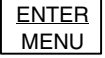
The display will briefly display .

4. Press  to choose user list.
5. Press  to edit a user.
A list of all the users will appear starting with the lowest user number.
6. Press the  or  arrow buttons to move through the user list.
7. When the equal sign highlights the user you wish to edit press .
8. If you **do not** want the user name changed, press .

Or

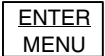

To change the user name, press the  or  arrow buttons to move through the available characters. (See Table 5–18 for list of available characters.) When the name change is complete press .

9. If you **do not** want the PIN code changed, press .

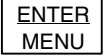
Or

To change the PIN code, enter the desired code (4 to 9 digits in length) then press .

The display will flash the current profile level.

10. Press the  or  arrow buttons to toggle between Installer and Operator.

11. When the desired profile level is flashing press .

5.5.3 Clearing a User Out of the Receiver

Use the following steps to clear or delete a user from the system:

1. Log on to the receiver. (See Section 4.4.4 for log on procedure.)

2. Press  button.

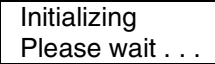

3. Press  for program menu.

The display will briefly display .

4. Press  to choose user list.

5. Press  to clear (delete) a user.

A list of all the users will appear starting with the lowest user number.

6. Press the  or  arrow buttons to move through the user list.

7. When the equal sign highlights the user you wish to clear press .

The display shows .

8. Press the  or  arrow button to toggle the flashing display to Yes.

9. Press .

Section 6 Compatible Reporting Formats

This section lists all the reporting formats that are compatible with the MX8000 receiver.

Table 6–1 shows the formats that the MX8000 receiver can decode and handshake frequency format group that accommodates that format (see Section 5.3.6 for line card programming). Each line card can decode every format listed below; however, a line card can be programmed to prioritize the handshake order in which that line card will communicate.

6.1 Formats By Communication Group.

Table 6–1 shows which formats fit under the general communication groups and the corresponding handshake frequency.

Table 6–1: Formats compatible with the MX8000

Communication Group	Format Name	Description	Handshake Format Group
Tone Burst	SK 4+2	Sends a 4-digit account and a 2-digit alarm code up to four rounds.	1400 Hz
	Sescoa 3+1/Franklin 3+1	Sends a 3-digit account and a 1-digit alarm code up to four rounds in a tone burst format. Each digit can be programmed from (0-9). Because there is no standard, this format reports in codes only.	2300 Hz
	Radionics 3+1 Checksum	Sends a 3-digit account and a 1-digit alarm code and a checksum.	1400 or 2300 Hz
	SK 3+1/3+1 Extended	Sends a 3-digit account and a 1-digit alarm code up to four rounds (10-40PPS). Each block of data (2 rounds). If a second block of data is sent, it will contain the extended information. The account number cannot have repetitive digits (333, 888, etc.).	1400 or 2300 Hz
	4+1/4+1 Extended	Sends a 4-digit account code and a 1-digit alarm code up to four rounds in a pulse format (10-40PPS).	4/1 1400 or 4/1 2300 Hz
	Pulse 4+2	Sends a 4-digit account code and a 2-digit alarm code.	1400 or 2300 Hz
DTMF	ADEMCO Contact ID®, ADEMCO Contact ID10	Dual Tone Multiple Frequency. The data is decoded into English account information.	1400_2300 Hz
	ADEMCO High Speed	Sends a 4-digit account code and a 2-digit alarm code up to 9 events per call.	
	Acron TouchTone	Sends a 4-digit account code and a 1-digit alarm code. Will send a maximum of 8 events per call.	
	ADEMCO Express	Sends a 4-digit account code and a 2-digit alarm code with a checksum.	
	DTMF 4+2	Sends a 4-digit account code and a 2-digit alarm code with a checksum.	
	FBII 4+3+1	Sends a 4-digit account code, a 3-digit zone code and a 1-digit event code.	1400 or 2300 Hz
	Westec	Sends a 4-digit account code, a 3-digit Dealer code followed by the event code.	Westec

Table 6–1: Formats compatible with the MX8000 (cont'd)

Communication Group	Format Name	Description	Handshake Format Group
FSK	SX-III, SX-IVA	Sends a 5-digit account code in a Bell 103 format with checksum. The data is decoded into English account information.	2225 Hz
	SX-IVB		
	ITI SX-V		
	ITI Commander		
	ITI RF Commander, Harbor Gard		
	ITI Commander 2000, LifeGard		
	ITI CareTaker+, SecurityPro 4000		
	ITI UltraGard		
	SIA DCS (Digital Communication Standard)	The data is decoded into English account information.	
	BFSK	Sends a 3-digit account and a 1-digit alarm code, similar to 3+1 Extended format except the data is decoded into English account information.	1400 or 2300 Hz
FSK II, FSK 86	Sends a 6-digit account code with a 2-digit alarm type and 2-digit zone number. Sends a check XOR and checksum. 1 to 8 events per call.	1400 Hz	
Modem II	Sends a 4-digit account code with multiple 2-digit event codes.	Modem II	
Modem IIe	Sends a 4-digit account code with multiple 2-digit event codes.	Modem IIe	
Varitech FSK 4+1	Sends a 4-digit account code and a 1-digit alarm code with multiple rounds.	1400 or 2300 Hz	
Varitech FSK 4+2	Sends a 4-digit account code and a 2-digit alarm code with multiple rounds.	1400 or 2300 Hz	

6.2 Format Numbers Used In Printer Output

In a printed report the format used by a calling panel is listed as a number, that number represents a particular format. Table 6–2 lists these numbers along with the corresponding format.

Table 6–2: Formats By Report Number

Format Number	Format Type	Format Number	Format Type
4	SIA DCS	55	ADEMCO High Speed (SIA D1) output as SIA events when using the ADEMCO 8000, SK9000 or ITI Automation Protocol. ADEMCO High Speed output as raw data (ADEMCO format) when using the 685, CAPS, or CP220 Automation Protocol.
9	ITI	56	ADEMCO High Speed with checksum (SIA D1) output as SIA events when using the ADEMCO 8000, SK9000 or ITI Automation Protocol. ADEMCO High Speed with checksum output as raw data (ADEMCO format) when using the 685, CAPS, or CP220 Automation Protocol.
10	ITI SX-IVA	57	ADEMCO DTMF 4/2 with checksum
11	ITI PinPoint	58	ADEMCO DTMF 4/1 with checksum
12	ITI RF Commander	59	Acron TouchTone 4 digit account.
13	ITI Pro 1 or ITI Ultragard	60	BFSK
14	ITI CareTaker +	61	Silent Knight FSK0/FSK80
15	ITI SX-V	62	Silent Knight FSK1/FSK81
16	ITI Commander 2000	63	Silent Knight FSK2/FSK86
17	ITI HarborGuard	64	FBII 4/3/1 with checksum or FBII 4/1/2/1 with checksum
18	ITI Reserved or ITI Simon	65	FBII 4/3/1 or FBII 4/1/2/1
19	ITI Vector	70	Westec 871
20	ITI Hardwire Commander	71	Westec W970
21	ITI SX-V Special	72	Westec W1000, W2000, W3000
22	ITI Marsden	73	Westec 45K
23	ITI Network Sec	74	Modem II
24	ITI Nutone	75	Modem IIe
25	ITI SX-IVB	80	Pulse 32
30	Pulse Tone 3/1	81	Pulse 32 CS
31	Sescoa Franklin 3/1	82	Pulse 41 CS
32	ADEMCO/Silent Knight 3/1	83	ADEMCO Contact ID® 10-digit Account
33	Extended 3/1	100	ITI Simon U
35	Pulse tone 4/1	101	Varitech FSK 4/1
36	Sescoa Franklin 4/1	102	Varitech FSK 4/2
37	ADEMCO/Silent Knight 4/1	103	Ademco High Speed output in high speed raw data (ADEMCO format) when using ADEMCO 8000, SK9000 or ITI Automation Protocol
38	Extended 4/1	104	Ademco High Speed with checksum output in high speed raw data (ADEMCO format) when using ADEMCO 8000, SK9000 or ITI Automation Protocol
40	Pulse Tone 4/2		
41	ADEMCO/Silent Knight 4/2		
43	Extended 4/2		
46	Radionics 3/1		
47	Radionics 3/1 with Checksum		
48	Radionics 4/2 with Checksum		
49	Sescoa Superspeed		
50	Contact ID		
51	ADEMCO TouchTone		
52	Acron TouchTone		
53	Westec TouchTone		
54	ADEMCO Express		

!WARNING!

- If you are receiving Contact ID®10 format on your MX8000 receiver you must use ADEMCO 8000 automation protocol.
- If you are receiving Contact ID® format on your MX8000 receiver you may use any automation protocol except the SK9000 automation protocol. The SK9000 automation protocol does not support Contact ID reporting format.

Important!

Due to the increasing number of formats a single line can accept and the wide variety of manufacturer's specifications for handshake/acknowledgement tones required for their digital dialers to communicate, we strongly recommend observing the following rules for handshake tone order.

1. Some SIA DCS communicators respond to the 2300Hz handshake. Always place the 2225Hz handshake tone first for line cards accepting SIA DCS format.
2. Some Contact ID communicators respond to the 1400Hz handshake followed by the 2300Hz handshake instead of the dual tone 1400-2300Hz handshake (NAPCO Gemini communicators have been known to do this). Line cards accepting Contact ID should not have the 1400Hz followed by the 2300Hz before the dual tone 1400-2300Hz handshake.
3. SIA DCS communicators will respond to the Modem II and IIe handshakes. If a line card is to accept both SIA DCS and Modem II or IIe, the 2225Hz handshake must come before the Modem II and Modem IIe handshakes.
4. Some Westec panels will respond to the Modem II handshake. If a line card is to accept both Westec and Modem II formats, the Westec handshake must come before the Modem II handshake.
5. Some of ITI panels don't respond to the default 2225Hz handshake. They need a lot longer handshake duration than what we have in the MX8000 receiver. You don't want to change the default 2225Hz handshake (1st handshake group) because it's optimized for SIA panels. What you should do is to program the 2nd 2225Hz handshake group with a long handshake duration (say 2550 ms). This way, a SIA panel responds to the 1st 2225Hz handshake and ITI panels respond to the 2nd 2225Hz handshake.
6. 4/1 pulse format and 3/1 with check sum pulse format look exactly alike to the receiver. Both respond to the 1400Hz or 2300Hz handshake and both contain 5 pulses. You cannot send both signals to the same line card. To process data correctly, you must specify in the line card handshake option which format you are expecting to receive. To receive 4/1 pulse format, you must program one of the six handshake groups of the line card to be 4/1 1400Hz and/or 4/1 2300Hz (This is the default setting). If you want to handle 3/1 with check sum, program the line card with 1400Hz and/or 2300Hz. If both 2300Hz and 4/1 2300Hz are programmed in a line card, 4/1 is assumed regardless of what order you program handshake groups. If your customer must handle both 4/1 and 3/1 with check sum formats, he or she must send the signals to separate line cards.

Section 7 Troubleshooting

This section contains a list of possible error messages and a troubleshooting process for each.

7.1 Error Messages

Table 7–1 lists the error messages that are displayed on the VFD of the receiver as well as the message sent to the printer. There are two types of error messages that are displayed and printed, line card communication errors, and system event errors. Line card communication errors relate specifically to how the receiver communicated to an incoming call. System event errors relate specifically to the system and the performance of its peripheral devices such as the automation software, printers, etc. In Table 7–1, heading “LC Error” indicates that the error message was a line card communication error and “SYS Error” indicates any system event related error messages.

Table 7–1: Error Messages

LC Error	Sys Error	VFD Messages	Printer Message	Description	What to Do
✓		No Data Received	No Data Received	On an incoming call no data was sent to the receiver after the receiver gave its handshake tones.	Usually a wrong number.
✓		0 Length Block	0 Length Blk	One of the message blocks received contained no data.	Possibly a call with caller ID information but no data from a control panel.
✓		No Ack	No Ack	Receiver was unable to acknowledge the call.	Check the line card setup and retest the panel.
✓		Time Out	Time Out	The incoming call timed out and the phone line was released.	1. Retest Panel. 2. Replace panel.
✓		Corrupted Data	Corrupted Data	Bad or corrupted data was sent to the receiver.	3. Replace line card.
✓		Illegal Specifier	Illegal Specifier	An error occurred in the look-up table for this call message.	Call Technical Support.
✓		Undefined Event	Undefined Event	The panel communicating to the receiver sent an event code that the receiver does not recognize.	
✓		Unsupported Event	Unsupported Event	The panel communicating to the receiver sent an event code that the receiver recognized but does not support.	
✓		Unsupported Format	Unsupported Fmt	The calling panel communicated in a format not supported by the receiver.	Program the panel to a different reporting format.
✓		Communication Error	Communication Error, Panel Requested Re-send	There was a communication error between the panel and the receiver and the receiver asked the panel to re-send the message.	If it continues test the panel.
✓		Possible Incomplete	Possible Incomplete Call	The receiver missed information in the call sequence.	Retest the panel.
	✓	System Power Up	System Power Up	Indicated that the receiver powered up.	Check the connection of that device on the SBUS. If connection OK replace SBUS device (line cards and touchpads).

Table 7-1: Error Messages (cont'd)

LC Error	Sys Error	VFD Messages	Printer Message	Description	What to Do
	✓	Expander Trouble	Expander Trouble	Trouble with a device connected to the SBUS.	
	✓	Expander Trbl Rst	Expander Trouble Restore	The trouble condition of a SBUS device was corrected.	
	✓	AC Trouble	AC Trouble	AC power failure.	Check AC outlet and AC power cord.
	✓	AC Trouble Rst	AC Trouble Restore	AC power was restored.	Restores at 12VDC after a low battery condition.
	✓	Battery Low Restore	Battery Low Restore	The backup battery power supply trouble has been corrected.	
	✓	Battery Low	Battery Low	The backup battery is checked continually every second. This message would be displayed if the backup battery were set to "Battery Bkp". See Section 5.3.4. Indicates a low battery when the voltage drops to 10.2 VDC or lower.	Check battery cables. If they are OK replace backup battery.
	✓	Local Program Begin	Local Program Begin User #	This message indicates the time a system "installer" entered program mode.	
	✓	Local Program End	Local Program End User #	This message indicates the time a system "installer" exited program mode.	
	✓	Local Program Fail	Local Program Fail User #	The receiver will stay in program mode for 15 minutes without any activity, then it will time out and go back to normal mode. This message indicates that an installer entered programming and did not exit programming before it timed out.	
	✓	Listen-in End	Listen-in End	A listen-in session completed	
	✓	Listen-in Begin	Listen-in Begin	A listen-in session started.	
	✓	System Date Changed	System Date Changed User #	An installer changed the system date.	
	✓	System Time Changed	System Time Changed User #	An installer changed the system time.	
	✓	Msg Queue Full	Message Queue Full	Messages can be sent to automation computer, a printer or can be manually acknowledged. If one or more of these devices does not respond to messages being sent or manually acknowledged, the message queue will fill up. When the message queue is full the receiver will no longer accept incoming calls.	Verify that messages are acknowledged to any printers, automation software, and while in manual mode.
	✓	Msg Queue Full restore	Message Queue Full restore	Indicates that the message queue full error has been corrected.	
	✓	Main Computer Trbl	Main Computer Trouble	A communication problem exists between the automation software and the receiver.	Check cable connections. Verify that the port is configured properly.
	✓	Main Computer Rst	Main Computer Restore	The communication error between the receiver and the automation software has been corrected.	

Table 7–1: Error Messages (cont'd)

LC Error	Sys Error	VFD Messages	Printer Message	Description	What to Do
	✓	Bkup Computer Trbl	Bkup Computer Trouble	A communication problem exists between the backup automation software and the receiver.	Check cable connections. Verify that the port is configured properly.
	✓	Bkup Computer Rst	Bkup Computer Restore	The communication error between the receiver and the backup automation software has been corrected.	
	✓	Main Prn Off Trbl	Main Printer Off Line	The port programmed as the primary printer port is off line.	Check cable connections. Verify that the port is configured properly. Check power to printer.
	✓	Main Prn Paper Out	Main Printer Paper Out	The port programmed as the primary printer port is out of paper.	Replace paper in printer.
	✓	Main Prn Restore	Main Printer Restore	The error on the primary printer has been corrected.	
	✓	Bkup Prn Off Trbl	Bkup Printer Off Line	The port programmed as the backup printer port is off line.	Check cable connections. Verify that the port is configured properly. Check power to printer.
	✓	Bkup Prn Paper Out	Bkup Printer Paper Out	The port programmed as the backup printer port is out of paper.	Replace paper in printer.
	✓	Bkup Prn Restore	Bkup Printer Restore	The error on the backup printer has been corrected.	
	✓	DC Input Low Rst	DC Input Low Restore	The backup DC power supply trouble has been corrected.	Restores at 12VDC after a low battery condition.
	✓	DC Input Low	DC Input Low	The backup battery is checked continually every second. This message would be displayed if the backup battery setting were set to "DC Bkp". See Section 5.3.4. Indicates a low when the voltage drops to 10.2 VDC or lower.	Check the connection to the DC power supply. Verify the output from DC power supply.
	✓	Msg Que > Warning	Message Queue Warning	When the message queue reaches the programmed level mark, this message is given as a pre-warning to "Message Queue Full". See Section 5.3.5.1 to program the % level at which the receiver will indicate the warning.	Verify that messages are acknowledged to any printers, automation software, and while in manual mode.
	✓	Msg Que < Warning	Message Queue Warning Restore	This message is given when the message queue drops below the programmed level after a message queue warning indication has displayed. See Section 5.3.5.2 to program the % level.	
	✓	LC Run in ROM	Line Card Running ROM Code	The line card is not running the application code.	Replace the line card.
	✓	Line Fault	Line Fault	The phone line voltage has dropped below the threshold voltage as programmed. (See Section 5.4.2.3.)	Check phone line outlet and phone cord.

Table 7-1: Error Messages (cont'd)

LC Error	Sys Error	VFD Messages	Printer Message	Description	What to Do
	✓	Line Fault Restore	Line Fault Restore	Phone line voltage has been restored to normal parameters.	
	✓	LinePort Deleted	LinePort Record Deleted	A line card has been deleted.	
	✓	LinePort Added	LinePort Record Added	A line card has been added.	
	✓	User Log In	User Log In: User #	A user has logged on to the receiver.	
	✓	User Log Out	User Log Out: User #	A user has logged off of the receiver.	

7.2 Unrecognized Reports

The MX8000 provides an output to the printer when a report is received in an unrecognized reporting format. This may happen in cases where the automation protocol selected does not match the reporting format set for a client. Examples of a good report and unrecognized report are provided below:

Good Report	Unrecognized Report
<p>In the example below, a Contact ID report was received and the MX8000 is set for ADEMCO 685 protocol.</p> <pre>[New] Opening-Cancel ID# 304 Group# 00 [New] Closing-Report ID# 004 Group# 00 [New] Opening-Report ID# 004 Group# 00</pre>	<p>In the example below, a Contact ID report was received and the MX8000 is set for SK9000 protocol which does not support Contact ID.</p> <pre>05/14/2002 11:00:51AM Device #: 1-2 Format #: 0 Reference #: 119 No Data Received</pre>

7.3 Troubleshooting Process

Before you call Technical Support you may be able to solve the problem yourself by following these procedures.

1. Verify that a problem exists.
2. Check Fault Status.

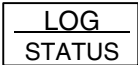
This can be done by pressing the . If the system fault LED is on, the display will read:

```
#01-Installer
Log Out
[]
<Press ↓ for status>
```

Press the down arrow to view fault messages.

3. Check the manual for suggestions or solutions.
4. Check connections.
5. Isolate the problem. Remove other devices that may be interfering.
6. Try swapping devices to isolate the problem.
7. Try to replace the problematic device.
8. Document the failures and the steps used to resolve them.

7.3.1 Removing the CPU, PS, User Interface Assembly

Once Technical Support has determined that a problem exists with either the CPU, Power Supply, or the User Interface, use the following procedure to remove the assembly and return it to Honeywell for repair.

1. Disconnect AC power Cable.
2. Disconnect the backup battery. (See Figure 3–14.)
3. Remove the front plate by unscrewing the front plate retaining screws. (See Figure 3–1 for locations of front plate retaining screws.)
4. On the back of the receiver remove the four screws that hold the CPU, PS, User Interface Assembly to the chassis. (See Figure 7–1 for screw locations.)

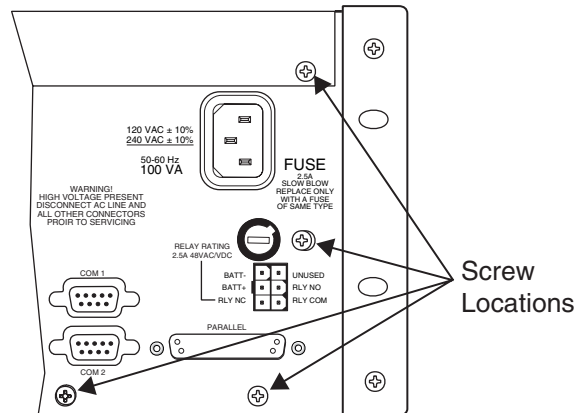

Figure 7–1: User CPU, PS, User Interface Assembly retaining Screw Locations

5. From the front of the receiver, pull the CPU, PS, User Interface Assembly out of the receiver chassis.

7.3.2 Replacing the CPU, PS, User Interface Assembly

1. From the front of the receiver, slide the replacement CPU, PS, User Interface Assembly back into the receiver chassis.
2. On the back of the receiver, replace the four screws that hold the CPU, PS, User Interface Assembly in place. (See Figure 7–1.)
3. Reconnect the AC power cable.

Note: Make sure to plug the AC power cable into a grounded outlet. (See Section 3.11.2 for procedure on how to verify earth ground.)

4. Reconnect the back-up battery. (See Figure 3–14.)
5. Replace the front plate by screwing in the front plate retaining screws. (See Figure 3–1.)

7.4 Safe Mode

Safe mode can be used to reset User #01 access code back to default of MX8000 regardless of its present setting.

For Example, if the code for the installer (User #01) is lost and additional programming is required the receiver can be restarted in safe mode to return User #01 to an access code of 8000.

Follow these steps to initiate Safe Mode and default User code #01:

1. Follow the steps in Section 4.6.7 to restart the receiver.

Note: All messages must be acknowledged before a system restart procedure can be performed. If all messages are not acknowledged, cycle the receiver's power to restart the system. If the power is cycled all unacknowledged messages will be lost.

2. When the display Shows

Model MX8000 Receiver ADEMCO

3. Press the button, then the button.

The display will read

4. Press .
5. Enter the default Installer code or 8000.

Section 8 Automation Communication Formats

8.1 Introduction

The receiver supports several automation communication formats that are used to communicate with an automation computer. The supported formats are Silent Knight’s proprietary protocol. The ADEMCO protocol is described in Section 8.2.

!WARNING!

- If you are receiving Contact ID[®]10 format on your MX8000 receiver, your automation software must be compatible with 10-digit account numbers, you must not use SK9000, ITI Generic, or ITI Enhanced automation protocols, and you must not use the MX8000-LC1 Line Card.
- If you are receiving Contact ID[®] format on your MX8000 receiver you may use any automation protocol except the SK9000 automation protocol. The SK9000 automation protocol does not support Contact ID reporting format.

8.1.1 Conventions Observed In This Section

This manual uses the term “automation computer” to refer to a computer that receives data from the MX8000 and interprets it through software that automates the central station.

For the purposes of this manual, a “message” is any data the MX8000 is passing to an automation computer. We’ll reserve the term message for discussions of the string as a whole.

The term “call from panel” will refer to the complete data stream from a panel to the MX8000. The term “event data” will refer to the actual data, (that is, alarms, troubles, and so on), that are part of a call from a panel.

The term “system message” will refer to messages the MX8000 sends to an automation computer about its internal status.

Another convention of this manual is to use hexadecimal values to refer to data (rather than the ASCII characters that represent the values). Hexadecimal numbers will be represented with a \$ symbol in front of them as in “\$0A”.

8.2 MX8000 Automation Protocols

The automation protocols available in the MX8000 are listed in Table 8–1 with a protocol description and automation computer setting.

RECOMMENDATION

We recommend using the ADEMCO 8000 automation protocol to take full advantage of all the formats and features of the MX8000.

Table 8–1: Automation Protocol Listing

MX8000 Setting	Description	Automation Computer Setting
ADEM 8000	ADEMCO 8000 Protocol	Ademco 8000 or Silent Knight Expanded
ADEM 685	ADEMCO 685 Protocol	Ademco 685
CAPS	ADEMCO Caps Protocol	Ademco Caps
FBII220	FBII CP-220 Protocol	FBII CP220
SK9000	Silent Knight 9000 Emulation	Silent Knight 9000
ITI Gen	ITI Generic	ITI Generic
ITI Comp	ITI Comp	ITI Comp

8.3 Reporting Formats and Automation Protocol Support

Table 8–2 provides a listing of the reporting formats supported by each type of automation protocol in the MX8000.

Table 8–2: Reporting Formats and Automation Protocol Support

Reporting Format		Automation Protocol						
		ADEMCO 8000	ADEMCO 685	ADEMCO 685 CAPS	FBII CP220	SK9000	ITI Generic	ITI Enhanced
1400/2300 Hz Pulse	3/1, 3/1 Ext	YES	YES	YES	YES	YES	YES	YES
	3/1 Even Round	YES	YES	YES	YES	YES	YES	YES
	3/1 w/cksum	YES	YES	YES	YES	YES	YES	YES
	3/1 Ext w/cksum	YES	YES	YES	YES	YES	YES	YES
	3/2	YES	YES	YES	YES	YES	YES	YES
	3/2 Even Round	YES	YES	YES	YES	YES	YES	YES
	3/2 w/cksum	YES	YES	YES	YES	YES	YES	YES
	4/1, 4/1 Ext	YES	YES	YES	YES	YES	YES	YES
	4/1 Even Round	YES	YES	YES	YES	YES	YES	YES
	4/1 w/cksum	YES	YES	YES	YES	YES	YES	YES
	4/1 Ext w/cksum	YES	YES	YES	YES	YES	YES	YES
	4/2	YES	YES	YES	YES	YES	YES	YES
	4/2 Even Round	YES	YES	YES	YES	YES	YES	YES
	4/2 w/cksum	YES	YES	YES	YES	YES	YES	YES
DTMF	Acron Touchtone w/ 3-digit account	YES	YES	YES	YES	YES	YES	YES
	Acron Touchtone w/ 4-digit account	YES	YES	YES	YES	YES	YES	YES
	ADEMCO 4/1 w/cksum	YES	YES	YES	YES	YES	YES	YES
	ADEMCO 4/2 w/cksum	YES	YES	YES	YES	YES	YES	YES
	ADEMCO High Speed	YES	YES	YES	YES	YES	YES	YES
	ADEMCO High Speed w/cksum	YES	YES	YES	YES	YES	YES	YES
	Contact ID	YES	YES	YES	YES	NO	YES	YES
	Contact ID10	YES	YES	YES	YES	NO	NO	NO
	FBII 4/3/1	YES	NO	NO	YES	YES	YES	YES
	FBII 4/3/1 w/cksum	YES	NO	NO	YES	YES	YES	YES
	FBII Superfast							
	Westec 970	YES	NO	NO	NO	YES	YES	YES
	Westec 1000/2000/3000	YES	NO	NO	NO	YES	YES	YES
FSK	BFSK	YES	YES	YES	YES	YES	YES	YES
	FSK0/FSK 8	YES	NO	NO	NO	YES	YES	YES
	FSK1/FSK 81	YES	NO	NO	NO	YES	YES	YES
	FSK2/FSK 86	YES	NO	NO	NO	YES	YES	YES
	ITI CareTaker+, SecurityPro 4000	YES	NO	NO	NO	YES	YES	YES
	ITI Commander	YES	NO	NO	NO	YES	YES	YES
	ITI Commander 2000, LifeGard	YES	NO	NO	NO	YES	YES	YES
	ITI RF Commander, Harbor Gard	YES	NO	NO	NO	YES	YES	YES
	ITI SX-V	YES	NO	NO	NO	YES	YES	YES
	ITI UltraGard	YES	NO	NO	NO	YES	YES	YES
	Radionics Modem II	YES	NO	NO	NO	YES	YES	YES
	Radionics Modem IIE	YES	NO	NO	NO	YES	YES	YES
	SIA DCS	YES	NO	NO	NO	YES	YES	YES
	SX-III, SX-IVA	YES	NO	NO	NO	YES	YES	YES
	SX-IVB	YES	NO	NO	NO	YES	YES	YES
	Varitech FSK 4/1	YES	YES	YES	YES	YES	YES	YES
Varitech FSK 4/2	YES	YES	YES	YES	YES	YES	YES	

8.4 ADEMCO 8000

Because of the additional features and program capabilities of the MX8000 receiver over its predecessor the 9000 receiver, it was necessary to develop a new automation protocol.

ADEMCO 8000 protocol addresses these needs. The following sections describes the three different types of data blocks (system message, heart beat message, and call message) that the ADEMCO 8000 will send to the automation computer, and the components of these data blocks.

Each of these types of data blocks is preceded with an AE header block. At the end of each message is an "End of message indicator" (<\$0D> or carriage return) preceded by a Validation Byte (or V-Byte used for error-checking). See Section 8.4.5.

8.4.1 AE Header Block

The header block consists of 18 bytes of data and precedes all of the data blocks.

The following is an example of an AE header.

Example:

```
<Identifier><Date><$22><Time><$22><Rec#><$22><Ref#><$22>
```

Table 8–3 describes the components of an AE header block.

Table 8–3: AE Header Block Components Description

Character	Description	Acceptable Values
<Identifier>	Message type identifier.	\$02 System Message \$03 Heart Beat Message \$26 Call Message
<Date>	Date information, consisting of six ASCII bytes.	MMDDYY format where MM = Month, DD = Day, YY = Year.
<\$22>	Separator	N/A
<Time>	Time information, consisting of six ASCII bytes	HHMMSS format, where HH = Hour, MM = Minutes, SS = Seconds.
<\$22>	Separator	N/A
<Rec#>	Receiver ID number.	01-99
<\$22>	Separator	N/A
<Ref#>	Reference number, consisting of four ASCII bytes.	0001-9999 (0000 is reserved for link tests.)
<\$22>	Separator	N/A

8.4.2 Call Message Block

A call message is generated any time a control panel calls into the receiver. This type of report will be the most frequent message block received by the automation computer from the receiver.

Embedded in this message are the account number, time/date stamp, specific event information, along with any other miscellaneous information such as, caller ID, listen-in, etc.

The following is a generic example of a call message block:

Example: <AE header><Fmt#><LC#><Panel Data><V-byte><\$0D>

Table 8–4 describes the components of a call message block.

Table 8–4: Call Message Components and Description

Character	Description	Acceptable Values
<AE header>	AE header block of data.	See Section 8.4.1.
<Fmt#>	Dialer format number containing three ASCII digits.	See 8.4.2.1.
<LC#>	Line Card number containing two ASCII digits.	00-99
<Panel Data>	Contains account number, time/date stamp, caller ID information, listen-in, reason for call, zone number, etc.	See 8.4.2.2.
<V-byte>	Validation byte.	See Section 8.4.5.
<\$0D>	End of message indicator (carriage return).	N/A

8.4.2.1 Dialer Format

The ADEMCO 8000 format takes advantage of additional format numbers and outputs information with greater detail about the dialer format.

Table 8–5 lists the dialer format code and indicates the type of dialer associated with that number.

Table 8–5: Dialer Format Types By Code

Code	Dialer Type
004	SIA DCS
009	ITI
010	ITI SX-IVA
011	ITI PinPoint
012	ITI RF Commander
013	ITI Pro 1 or ITI Ultragard
014	ITI CareTaker +
015	ITI SX-V
016	ITI Commander 2000
017	ITI HarborGuard
018	ITI Reserved or ITI Simon
019	ITI Vector
020	ITI Hardwire Commander
021	ITI SX-V Special
022	ITI Marsden
023	ITI Network Sec
024	ITI Nutone
025	ITI SX-IVB
030	Pulse Tone 3/1
031	Sescoa Franklin 3/1
032	ADEMCO/Silent Knight 3/1
033	Extended 3/1
035	Pulse tone 4/1
036	Sescoa Franklin 4/1
037	ADEMCO/Silent Knight 4/1
038	Extended 4/1
040	Pulse Tone 4/2
041	ADEMCO/Silent Knight 4/2
043	Extended 4/2
046	Radionics 3/1
047	Radionics 3/1 with Checksum
048	Radionics 4/2 with Checksum
049	Sescoa Superspeed
050	Contact ID
051	ADEMCO TouchTone

Code	Dialer Type
052	Acron TouchTone
053	Westec TouchTone
054	ADEMCO Express
055	ADEMCO High Speed (SIA D1) output as SIA events
056	ADEMCO High Speed with checksum (SIA D1) output as SIA events
057	ADEMCO DTMF 4/2 with checksum
058	ADEMCO DTMF 4/1 with checksum
059	Acron TouchTone 4 digit account.
060	BFSK
061	Silent Knight FSK0/FSK80
062	Silent Knight FSK1/FSK81
063	Silent Knight FSK2/FSK86
064	FBII 4/3/1 with checksum or FBII 4/1/2/1 with checksum
065	FBII 4/3/1 or FBII 4/1/2/1
070	Westec 871
071	Westec W970
072	Westec W1000, W2000, W3000
073	Westec 45K
074	Modem II
075	Modem IIe
080	Pulse 32
081	Pulse 32 CS
082	Pulse 41 CS
083	ADEMCO Contact ID® 10-digit Account
100	ITI Simon U
101	Varitech FSK 4/1
102	Varitech FSK 4/2
103	Ademco High Speed output in high speed raw data (ADEMCO format)
104	Ademco High Speed with checksum output in high speed raw data (ADEMCO format)

8.4.2.2 Panel Data

Panel data contains all the data that pertains to the control panel that dialed into the receiver, such as the account number, what kind of alarm, the zone number, caller ID information, etc. Each record contains an identifier byte followed by data.

Table 8–6 lists the characters used as identifiers and a description of each.

Table 8–6: Panel Data Identifiers and Descriptions

Character	Description
\$05	Account number field
11h	Caller ID name
12h	Caller ID phone number
13h	Caller ID, others
\$22	Event field (Good Data)

Character	Description
\$23	Event field (Bad data sent as hex-ASCII dump). See Section 8.11
\$2A	Listen-in call indicator. See Section 8.4.2.3.
\$2C	Long call indicator. See Section 8.4.2.4.

Note: *Caller ID to Automation* – When enabled, Caller ID information is output to the automation system only in the event that no alarm data is received from a security system control panel.

Example: <\$26><"051697"><\$22><"081356"><\$22><"01"><\$22><"0001"><\$22><"004"><"01"><12h><"1-800-328-0103"><11h><"ADEMCO"><\$05><"123456"><\$22><"BA01"><\$22><"DC2"><\$22><"RP"><V-byteV-byte><\$0D>

Table 8–7 describes what each component of the call message means.

Table 8–7: Call Message Components

Component	Description
<\$26>	Call message indicator.
<"051697">	Date-May 16th, 1997
<\$22>	Separator
<"081356">	Time-8:13:56 am
<\$22>	Separator
<"01">	Receiver number-1.
<\$22>	Separator
<"0001">	Reference number-0001
<\$22>	Separator
<"004">	Expanded dialer format -SIA DCS
<"01">	Line Card number-01
<12h>	Caller ID phone number indicator
<"1-800-328-0103">	Caller ID phone number
<11h>	Caller ID name field indicator
<"ADEMCO">	Caller ID name
<\$05>	Account number field indicator
<"123456">	Account number-123456
<\$22>	Good data field indicator.
*<"BA01">	Call event code-Burglary alarm, Zone 01.
<\$22>	Good data field indicator.
*<"DC2">	Call event code-Access Closed, Door 2
<\$22>	Good data field indicator.
*<"RP">	Call event code-Automatic Test
<V-byte>	Validation Byte (V-byte). See Section 8.4.5.
<\$0D>	End of message indicator

***Note:** Refer to SIA publication *"Digital Communication Standard, February 1995 Revision,"* or later for message syntax.

8.4.2.3 Listen-in Indicator

If message sent to the automation computer contains a <\$2A> (Listen-In indicator) followed the 3-ASCII digits, the control panel calling is requesting the receiver put the phone line into listen-in mode.

The MX8000 receiver uses the following standards to identify a listen-in account:

- First, the receiver searches for an embedded listen-in event in the panel data, depending on whether or not the reporting format supports listen-in.
- Second, the receiver compares the account number to those stored in the "listen-in accounts" list. See Section 5.4.2.4.
- Third, the receiver scans the line card flash record to determine if the listen-in is enabled for the line card.
- Fourth, if the above standards have been satisfied, the receiver sends the automation computer the listen-in indicator.

The following is an example of a call message containing a listen-in indicator:

Example: <FMT#><LC#><\$05><123456><BA01><\$2A><"060"><V-byte><\$0D>

Table 8–8 describes the components of a call message containing a listen-in indicator.

Table 8–8: Call Message With Listen-in Data

Character	Description
<AE header>	AE header block of data. See Section 8.4.1.
<FMT#>	Dialer format number containing three ASCII digits. See 8.4.2.1.
<LC#>	Line Card number containing two ASCII digits.
<\$05>	Panel Data. See 8.4.2.2.
<123456>	
<BA01>	
<\$2A>	Listen-in indicator.
<"060">	Listen-in time period in seconds. Three ASCII characters- 60 seconds.
<V-byte>	Validation byte. See Section 8.4.5.
<\$0D>	End of message indicator.

Note: If the control panel calling does not include the listen-in period in the reporting message, the receiver uses the listen-in timeout programmed in the line card. See Section 5.4.2.4.

8.4.2.4 Long Call Indicator

The maximum number of bytes the ADEMCO 8000 protocol can send to the automation computer in a single packet is 128. If a panel sends more than 128 bytes, the receiver will break the panel information data down into groups of 128 bytes or less. To alert the automation computer that this is being done, a long call indicator (<\$2C>) will be added before the V-byte to indicate more data is to follow.

The entire data string in a long call contains the same values in the header block. The last data string of the long call will not contain a long call indicator prior to the V-byte.

The example below shows the long call data excluding the AE header and the panel data.

...<\$2C><V-byte><\$0D>

Note: Some panels are capable of transmitting multiple account information in a single call. The MX8000 receiver will treat a call with multiple accounts as multiple calls with a single account and will divide the call into multiple data blocks. However, to distinguish them from a call with a single account, each data block of a call with multiple accounts will contain the same reference number and a long call indicator with the exception of the last block of data.

8.4.2.5 Bad Data Field Indicator

If the data received by the MX8000 is garbled or parts are missing the receiver will send a bad data indicator (<\$23> used in the event block as a separator) before the block of corrupted data. A bad data block will contain a hex-ASCII dump of the data in ASCII form.

The example below shows a bad data field indicator excluding the AE header and some of the panel data.

Example:

<\$23><aaaaaaaa><\$23><bbbbbb><\$05><"123456"><\$22><"BA01"><V-byte><\$0D>

Table 8–9 shows the character in the above example and gives a description for each.

Table 8–9: Bad Data Field Indicator Components

Character	Description
<\$23>	Bad data indicator
<aaaaaaaa>	Bad data ASCII hex data dump.
<\$23>	Bad data indicator
<bbbbbb>	Bad data ASCII hex data dump.
<\$05>	Account number field indicator
<"123456">	Account number.
<\$22>	Separator - Good data.
<"BA01">	Panel Data. See 8.4.2.2.
<V-byte>	Validation Byte. See Section 8.4.5.
<\$0D>	End of message indicator.

8.4.3 System Message Block

System messages originate from the receiver and are sent to the automation computer. The length of the message is dependent on its function of the message. All system messages are sent separately from one another and from other types of messages.

A typical system message looks like this: <AE header><System><V-byte><\$0D>

Example:

<\$02><"051697"><\$22><"124039"><\$22><"02"><\$22><"0001"><\$22><70h><"01"><V-byte><\$0D>

Table 8–10 lists the components of the system message block example and gives a description for each of them.

Table 8–10: System Message Components

Character	Description
<\$02>	Message type identifier.
<"051697">	Date information, consisting of six ASCII bytes.
<\$22>	Separator
<"124039">	Time information, consisting of six ASCII bytes
<\$22>	Separator
<"02">	Receiver number
<\$22>	Separator
<"0001">	Reference number, consisting of four ASCII bytes.
<\$22>	Separator
<\$70>	System event - line card trouble. See 8.4.3.1 for list of system messages.
<"01">	Line Card number - 01.
<V-byte>	Validation Byte (V-byte). See Section 8.4.5.
<\$0D>	End of message indicator.

8.4.3.1 System Messages

Table 8–11 lists all the system messages that the receiver can send to the automation computer.

Table 8–11: System Messages

System Message	Description	Hex Code to ASCII Character
<\$41><2 ASCII Byte LC #>	Common Listen-in Begin, followed by the line card number.	<\$41> = A
<\$42><2 ASCII Byte LC #>	Common Listen-in End, followed by the line card number.	<\$42> = B
<\$43><2 ASCII Byte LC #>	Common Listen-in Extended, followed by the line card number.	<\$43> = C
<\$44><2 ASCII Byte LC #>	PBX Listen-in Begin, followed by the line card number.	<\$44> = D
<\$45><2 ASCII Byte LC #>	PBX Listen-in Busy, followed by the line card Line card number.	<\$45> = E
<\$46><2 ASCII Byte LC #>	Manually Aborted Call, followed by the line card number.	<\$46> = F
<\$61>	System Power Up	<\$61> = a
<\$62><2 ASCII Byte User #>	Local Program Begin, followed by the user number.	<\$62> = b
<\$63><2 ASCII Byte User #>	Local Program End, followed by the user number.	<\$63> = c
<\$64><2 ASCII Byte User #>	Local Program Fail, followed by the user number.	<\$64> = d
<\$65><2 ASCII Byte User #>	System Date Change, followed by the user number.	<\$65> = e
<\$66><2 ASCII Byte User #>	System Time Change, followed by the user number.	<\$66> = f
<\$67>	Message Queue Above Warning	<\$67> = g
<\$68>	Message Queue Below Warning	<\$68> = h
<\$69>	Message Queue Full	<\$69> = i
<\$6A>	Message Queue Full Restore	<\$6A> = j
<\$6B>	Printer Off Line	<\$6B> = k
<\$6B>	Printer Paper Out	<\$6B> = l
<\$6D>	Printer Restore	<\$6B> = m
<\$6E><2 ASCII byte LC #>	LinePort or Slave Added	<\$6E> = n
<\$6F><2 ASCII byte LC #>	LinePort or Slave Deleted	<\$6F> = o
<\$70><2 ASCII byte LC #>	LinePort or Slave Trouble	<\$70> = p
<\$71><2 ASCII byte LC #>	Phone Line Trouble	<\$71> = q
<\$72><2 ASCII byte LC #>	LinePort or Slave Trouble Restore	<\$72> = r
<\$73><2 ASCII byte LC #>	Phone Line Restore	<\$73> = s
<\$77>	AC Lost	<\$77> = w
<\$78>	AC Restore	<\$78> = x
<\$79><4 ASCII byte Receiver Model #>	Battery/DC Trouble – Note: The Receiver Model Number output is 8000 indicating the MX8000 Receiver.	<\$79> = y
<\$7A><2 ASCII byte Receiver Model #>	Battery/DC Trouble Restore – Note: The Receiver Model Number output is 8000 indicating the MX8000 Receiver.	<\$7A> = z
<\$7B>	Computer Trouble	<\$7B> = {
<\$7D>	Computer Restore	<\$7D> = }
<\$7E><2 ASCII byte User #>	Log Off Operator	<\$7E> = ~
<\$7F><2 ASCII byte User #>	Log On Operator	<\$7F> = DEL

8.4.4 Heart Beat Message Block

A heartbeat is a message sent to the automation computer which is used to supervise the communication link between the receiver and the automation computer. A heartbeat can be identified by the reference number used in the AE header that will always be 0000. How often the heart beat message is sent to the automation computer is a programmable option in the receiver. (See Section 5.3.3.5.)

A typical heart beat message looks like this:

Example:

```
<$03><"051997"><$22><"074905"><$22><"01"><$22><"0000"><$22><V-byte><$0D>
```

Table 8–12 lists the components shown in the above example and gives a description for each of them.

Table 8–12: Link Test Components

Component	Description
<\$03>	Message type identifier.
<"051997">	Date information, consisting of six ASCII bytes.
<\$22>	Separator
<"074905">	Time information, consisting of six ASCII bytes
<\$22>	Separator
<"01">	Receiver number
<\$22>	Separator
<"0000">	Reference number, consisting of four ASCII bytes.
<\$22>	Separator
<V-byte>	Validation Byte (V-byte). See Section 8.4.5.
<\$0D>	End of message indicator.

8.4.5 Validation Byte (V-Byte)

A V-byte always precedes the end of message indicator and is the only error checking used by the ADEMCO 8000 communication format.

The following equations are used to calculate the V-byte:

1. Add the 1st byte of the message to the 2nd byte.
2. Clear bit 7 of the result.
3. Set bit 6 of the result.
4. Add this result to the next byte of the message.
5. Repeat steps 2 through 4 until the last byte of the event data. (Up to and including the byte preceding the validation byte.) The range of the sum is from \$40 to \$7F.

8.4.6 ACKing and NACKing Data

After the end of message byte (<\$0D>) is sent by the receiver, the automation computer will respond with an ACK (<\$06>) or NACK (<\$15>). This response can be delayed between 1 byte time (depending on the baud rate) and the ACK timeout period. See Section 5.3.3.5 page 5–18.

If the receiver doesn't get a response within the ACK timeout period or receive a NACK from the automation computer, it will retransmit the data.

After two NACKs or two ACKs timeout, the receiver will generate a **Computer Trouble** message. When a computer trouble message is generated, then the receiver will continually send a heartbeat until it receives an ACK from the automation computer. When communication is restored, a Computer Trouble Restore message will be generated.

8.4.7 Commands Initiated by the Automation Computer

Typically all communications are initiated by the receiver; however, there are several commands available to the automation computer to control or request information from the receiver. The automation computer may send these requests only when the receiver is not transmitting data to it.

The following sub-sections show the message format that must be sent from the automation computer to the receiver in order that these command requests function properly.

The receiver will respond to these requests from the automation computer with one of the following messages:

Table 8–13: Response Messages by the MX8000 Receiver

ASCII Hex Character	Character Name	Description
\$06	ACK	The request is granted.
\$15	NACK	The request is unrecognized because of one of the following reasons: <ul style="list-style-type: none"> • Checksum error • Invalid request code/format
\$1B	ESC (Escape)	The request is refused because of one of the following: <ul style="list-style-type: none"> • Unauthorized access • Invalid receiver/line card number • Receiver/line card is busy • Invalid PBX string • Account list full • Account number not found in the account list

Table 8–14 lists which request can be made from the automation computer by request identifiers.

Table 8–14: Command Requests by Identifiers

Command Request Identifier	Description
\$4A	Log-on request
\$4B	Log-off request
\$05	Hang up request
\$04	Add a listen-in account. (This adds an account number to the listen-in account list.)
\$03	Delete a listen-in account. (This deletes an account number from the listen-in account list.)
\$4C	Listen-in extend request.
\$48	Listen-in end request.
\$49	PBX string request.
\$0D	Link test request.

8.4.7.1 Remote Log-on/Log-off

You must log-on to the receiver before you can change any system program options. Remote log-in and log-off commands can be sent from the automation computer to the receiver.

To Log-in:

<\$4A><Receiver ID><\$22><User PIN><V-byte><\$0D>

Table 8–15: Log-in Request Components

Component	Description
<\$4A>	Command request identifier. See Table 8–14.
<Receiver ID>	Receiver ID number. 1 or 2 ASCII digits.
<\$22>	Separator
<User PIN>	The users PIN code.
<V-byte>	Validation Byte (V-byte). See 8.4.5.
<\$0D>	End of message indicator.

To Log-off:

<\$4B><Receiver ID><\$22><User PIN><V-byte><\$0D>

Table 8–16: Log-off Request Components

Component	Description
<\$4B>	Command request identifier. See Table 8–14.
<Receiver ID>	Receiver ID number. 1 or 2 ASCII digits.
<\$22>	Separator
<User PIN>	The user's PIN code.
<V-byte>	Validation Byte (V-byte). See 8.4.5.
<\$0D>	End of message indicator.

8.4.7.2 Force Hang-up Request

This command is used to immediately hang up the phone line regardless of the state of the line card.

To Force Hang-up:

```
<$05><Receiver ID><$22><LC#><V-byte><$0D>
```

Table 8–17: Force Hang-Up Request Components

Component	Description
<\$05>	Command request identifier. See Table 8–14.
<Receiver ID>	Receiver ID number. 1 or 2 ASCII digits.
<\$22>	Separator
<LC#>	The LinePort number.
<V-byte>	Validation Byte (V-byte). See 8.4.5.
<\$0D>	End of message indicator.

8.4.7.3 Add or Delete a Listen-in Account

If the account number of a control panel is in the listen-in account list, when that control panel calls in to the receiver, the receiver will perform a listen-in operation with that control panel. The maximum length of a listen-in account number is 8 characters and may include wild card characters (# and or *). Each line card can have up to 20 listen-in account strings. See also Section 5.4.2.4.

Note: *The listen-in account list applies to panels that do not send listen-in commands as a part of their message (Contact ID E606 or SIA LF and LE).*

To Add a Listen-in Account:

```
<$04><Receiver ID><$22><LC#><$22><Act#><V-byte><$0D>
```

Table 8–18: Add Listen-in Account Request Components

Component	Description
<\$04>	Command request identifier. See Table 8–14.
<Receiver ID>	Receiver ID number. 1 or 2 ASCII digits.
<\$22>	Separator
<LC#>	The LinePort number.
<\$22>	Separator
<Act#>	Account number to be added to the listen-in account list.
<V-byte>	Validation Byte (V-byte). See 8.4.5.
<\$0D>	End of message indicator.

To Delete a Listen-in Account:

```
<$03><Receiver ID><$22><LC#><$22><Act#><V-byte><$0D>
```

Table 8–19: Delete a Listen-in Account Request Components

Component	Description
<\$03>	Command request identifier. See Table 8–14.
<Receiver ID>	Receiver ID number. 1 or 2 ASCII digits.
<\$22>	Separator
<LC#>	The LinePort number.
<\$22>	Separator
<Act#>	Account number to be deleted from the listen-in account list.
<V-byte>	Validation Byte (V-byte). See 8.4.5.
<\$0D>	End of message indicator.

8.4.7.4 Common Listen-in Extend/End Request

During a listen-in operation if the call requires additional time you can extend the listen-in period by sending an extend request. At the end of a listen-in call you can end the session by sending an end request. Some control panels send a listen-in period included in the reported message to the receiver. If the listen-in period is not sent from the control panel, the programmed listen-in period will be used. See Section 5.4.2.4.

To Extend Listen-in:

<\$4C><Receiver ID><\$22><LC#><V-byte><\$0D>

Table 8–20: Extend Listen-in Period Request Components

Component	Description
<\$4C>	Command request identifier. See Table 8–14.
<Receiver ID>	Receiver ID number. 1 or 2 ASCII digits.
<\$22>	Separator
<LC#>	The LinePort number.
<V-byte>	Validation Byte (V-byte). See 8.4.5.
<\$0D>	End of message indicator.

To End a Listen-in Session:

<\$48><Receiver ID><\$22><LC#><V-byte><\$0D>

Table 8–21: End Listen-in Period Request Components

Component	Description
<\$48>	Command request identifier. See Table 8–14.
<Receiver ID>	Receiver ID number. 1 or 2 ASCII digits.
<\$22>	Separator
<LC#>	The LinePort number.
<V-byte>	Validation Byte (V-byte). See 8.4.5.
<\$0D>	End of message indicator.

8.4.7.5 PBX Listen-in String

When PBX listen-in mode is selected (see Section 5.4.2.4), the receiver will transfer the call to the extension X string. The PBX string can also be programmed in to the receiver from the automation computer.

To Create or Edit PBX String:

<\$49><Receiver ID><\$22><LC#><\$22><PBX String><V-byte><\$0D>

Table 8–22: Delete a Listen-in Account Request Components

Component	Description
<\$49>	Command request identifier. See Table 8–14.
<Receiver ID>	Receiver ID number. 1 or 2 ASCII digits.
<\$22>	Separator
<LC#>	The LinePort number.
<\$22>	Separator
<PBX String>	PBX string to transfer a call to a specified extension. See Table 5–13 for valid string characters.
<V-byte>	Validation Byte (V-byte). See 8.4.5.
<\$0D>	End of message indicator.

8.4.7.6 Link Test Request

The automation computer can send a link test request to the MX8000 receiver to test the communication link between the receiver and the automation computer. The automation computer simply sends a <\$0D> and the MX8000 receiver will respond.

8.5 ADEMCO 685 Automation Protocol

8.5.1 Low Speed 3x1, 4x1, and 4x1 Express Automation Protocols

When the MX8000 is operating in the ADEMCO 685 mode and receives a 3x1, 4x1, and 4x1 Express transmission, the output protocol to the computer is as shown in Figure 8–1. Note that when a 3x1 transmission is received, the account number will be padded to 4 characters by the addition of a leading 0 to the account number.

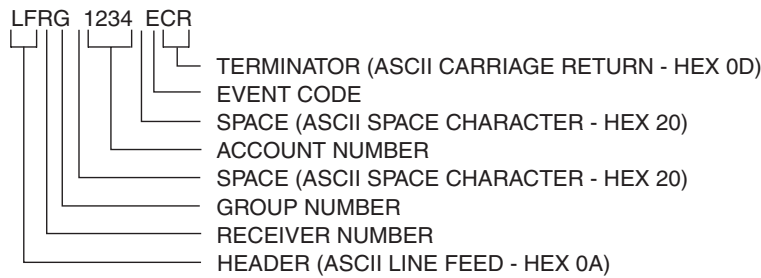

Figure 8–1: 685 3x1, 4x1, 4x1 Express Protocol

8.5.2 Low Speed 4x2 and 4x2 Express Automation Protocols

When the MX8000 is operating in the ADEMCO 685 mode and receives a 4x2 or 4x2 Express transmission, the output protocol to the computer is as shown in Figure 8–2.

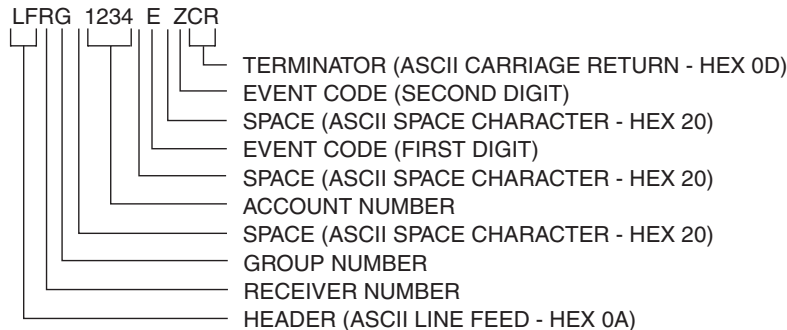

Figure 8–2: 685 4x2 and 4x2 Express Protocol

8.5.3 ADEMCO High Speed Automation Protocols

When the MX8000 is operating in the ADEMCO 685 mode and receives an ADEMCO High Speed transmission, the output protocol to the computer is as shown in Figure 8–3.

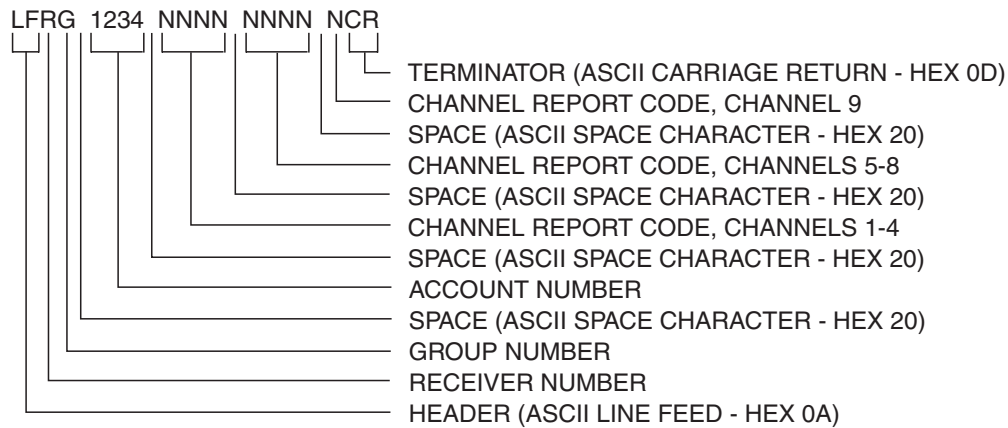

Figure 8-3: 685 ADEMCO High Speed Protocol

8.5.4 685 Contact ID

When the MX8000 receives a Contact ID[®] (also referred to as Point ID – PID) transmission while operating in the 685 mode, the output protocol to the computer is as shown in Figure 8-4.

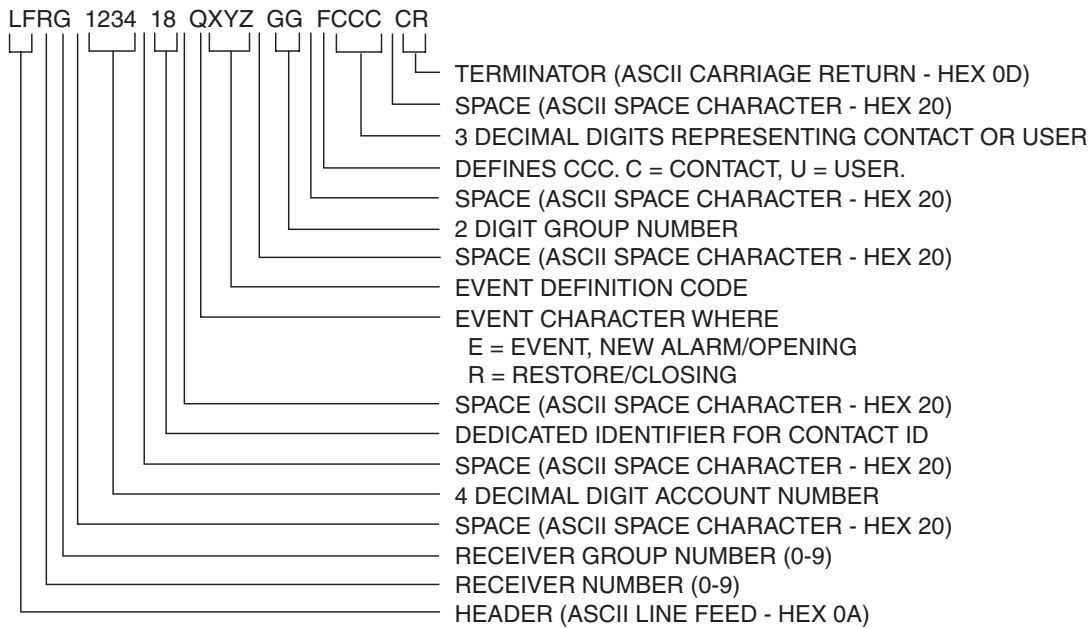

Figure 8-4: 685 Contact ID Protocol

ADEMCO DTMF formats will not transmit a true TouchTone “0” therefore, all “A”s are converted to 0 (zero) prior to output. The code string contains spaces at the points shown in Figure 8-4.

Contact ID Event Definition Codes are provided in Table 8-23.

Table 8–23: Contact ID Event Definition Codes

EVENT	DATA TYPE
ALARMS	
Medical Alarms -100	
100 Medical	Zone
101 Personal Emergency	Zone
102 Fail to report in	Zone
Fire Alarms -110	
110 Fire	Zone
111 Smoke	Zone
112 Combustion	Zone
113 Water flow	Zone
114 Heat	Zone
115 Pull Station	Zone
116 Duct	Zone
117 Flame	Zone
118 Near Alarm	Zone
126 Hold-up suspicion print	
Panic Alarms -120	
120 Panic	Zone
121 Duress	User
122 Silent	Zone
123 Audible	Zone
124 Duress – Access granted	Zone
125 Duress – Egress granted	Zone
126 Hold-up suspicion print	User
Burglar Alarms -130	
130 Burglary	Zone
131 Perimeter	Zone
132 Interior	Zone
133 24 Hour (Safe)	Zone
134 Entry/Exit	Zone
135 Day/night	Zone
136 Outdoor	Zone
137 Tamper	Zone
138 Near alarm	Zone
139 Intrusion Verifier	Zone
General Alarm -140	
140 General Alarm	Zone
141 Polling loop open	Zone
142 Polling loop short	Zone
143 Expansion module failure	Zone
144 Sensor tamper	Zone
145 Expansion module tamper	Zone
146 Silent Burglary	Zone
147 Sensor Supervision Failure	Zone
24 Hour Non-Burglary -150 and 160	
150 24 Hour Non-Burglary	Zone
151 Gas detected	Zone
152 Refrigeration	Zone
153 Loss of heat	Zone
154 Water Leakage	Zone
155 Foil Break	Zone
156 Day Trouble	Zone
157 Low bottled gas level	Zone

Table 8–23: Contact ID Event Definition Codes (continued)

EVENT	DATA TYPE
158 High temp	Zone
159 Low temp	Zone
161 Loss of air flow	Zone
162 Carbon Monoxide detected	Zone
163 Tank level	Zone
SUPERVISORY	
Fire Supervisory -200 and 210	
200 Fire Supervisory	Zone
201 Low water pressure	Zone
202 Low CO2	Zone
203 Gate valve sensor	Zone
204 Low water level	Zone
205 Pump activated	Zone
206 Pump failure	Zone
TROUBLES	
System Troubles -300 and 310	
300 System Trouble	Zone
301 AC Loss	Zone
302 Low system battery	Zone
303 RAM Checksum bad	Zone
304 ROM checksum bad	Zone
305 System reset	Zone
306 Panel programming changed	Zone
307 Self-test failure	Zone
308 System shutdown	Zone
309 Battery test failure	Zone
310 Ground fault	Zone
311 Battery Missing/Dead	Zone
312 Power Supply Over current	Zone
313 Engineer Reset	User
314 Primary Power Supply Failure	Zone
Sounder / Relay Troubles -320	
320 Sounder/Relay	Zone
321 Bell 1	Zone
322 Bell 2	Zone
323 Alarm relay	Zone
324 Trouble relay	Zone
325 Reversing relay	Zone
326 Notification Appliance Ckt. # 3	Zone
327 Notification Appliance Ckt. #4	Zone
System Peripheral Trouble -330 and 340	
330 System Peripheral trouble	Zone
331 Polling loop open	Zone
332 Polling loop short	Zone
333 Expansion module failure	Zone
334 Repeater failure	Zone
335 Local printer out of paper	Zone
336 Local printer failure	Zone
337 Exp. Module DC Loss	Zone
338 Exp. Module Low Batt.	Zone
339 Exp. Module Reset	Zone
341 Exp. Module Tamper	Zone
342 Exp. Module AC Loss	Zone
343 Exp. Module self-test fail	Zone
344 RF Receiver Jam Detect	Zone

Table 8–23: Contact ID Event Definition Codes (continued)

EVENT	DATA TYPE
Communication Troubles -350 and 360	
350 Communication trouble	Zone
351 Telco 1 fault	Zone
352 Telco 2 fault	Zone
353 Long Range Radio xmitter fault	Zone
354 Failure to communicate event	Zone
355 Loss of Radio supervision	Zone
356 Loss of central polling	Zone
357 Long Range Radio VSWR problem	Zone
Protection Loop -370	
370 Protection loop	Zone
371 Protection loop open	Zone
372 Protection loop short	Zone
373 Fire trouble	Zone
374 Exit error alarm (zone)	Zone
375 Panic zone trouble	Zone
376 Hold-up zone trouble	Zone
377 Swinger Trouble	Zone
378 Cross-zone Trouble	Zone
Sensor Trouble -380	
380 Sensor trouble	Zone
381 Loss of supervision - RF	Zone
382 Loss of supervision - RPM	Zone
383 Sensor tamper	Zone
384 RF low battery	Zone
385 Smoke detector Hi sensitivity	Zone
386 Smoke detector Low sensitivity	Zone
387 Intrusion detector Hi sensitivity	Zone
388 Intrusion detector Low sensitivity	Zone
389 Sensor self-test failure	Zone
391 Sensor Watch trouble	Zone
392 Drift Compensation Error	Zone
393 Maintenance Alert	Zone
OPEN/CLOSE/REMOTE ACCESS	
Open/Close -400, 440, 450, 460	
400 Open/Close	User
401 O/C by user	User
402 Group O/C	User
403 Automatic O/C	User
404 Late to O/C (Note: use 453, 454 instead)	User
405 Deferred O/C (Obsolete- do not use)	User
406 Cancel	User
407 Remote arm/disarm	User
408 Quick arm	User
409 Keyswitch O/C	User
441 Armed STAY	User
442 Keyswitch Armed STAY	User
450 Exception O/C	User
451 Early O/C	User
452 Late O/C	User
453 Failed to Open	User
454 Failed to Close	User
455 Auto-arm Failed	User
456 Partial Arm	User
457 Exit Error (user)	User
458 User on Premises	User
459 Recent Close	User
461 Wrong Code Entry	Zone

Table 8–23: Contact ID Event Definition Codes (continued)

EVENT	DATA TYPE
462 Legal Code Entry	User
463 Re-arm after Alarm	User
464 Auto-arm Time Extended	User
465 Panic Alarm Reset	Zone
466 Service On/Off Premises	User
Remote Access -410	
411 Callback request made	User
412 Successful download/access	User
413 Unsuccessful access	User
414 System shutdown command received	User
415 Dialer shutdown command received	User
416 Successful Upload	Zone
Access control -420, 430	
421 Access denied	User
422 Access report by user	User
423 Forced Access	Zone
424 Egress Denied	User
425 Egress Granted	User
426 Access Door propped open	Zone
427 Access point Door Status Monitor trouble	Zone
428 Access point Request To Exit trouble	Zone
429 Access program mode entry	User
430 Access program mode exit	User
431 Access threat level change	User
432 Access relay/trigger fail	Zone
433 Access RTE shunt	Zone
434 Access DSM shunt	Zone
435 Second Person Access	User
436 Irregular Access	User
BYPASSES / DISABLES	
System Disables -500 and 510	
501 Access reader disable	Zone
Sounder / Relay Disables -520	
520 Sounder/Relay Disable	Zone
521 Bell 1 disable	Zone
522 Bell 2 disable	Zone
523 Alarm relay disable	Zone
524 Trouble relay disable	Zone
525 Reversing relay disable	Zone
526 Notification Appliance Ckt. # 3 disable	Zone
527 Notification Appliance Ckt. # 4 disable	Zone
System Peripheral Disables -530 and 540	
531 Module Added	Zone
532 Module Removed	Zone
Communication Disables -550 and 560	
551 Dialer disabled	Zone
552 Radio transmitter disabled	Zone
553 Remote Upload/Download disabled	Zone
Bypasses -570	
570 Zone/Sensor bypass	Zone
571 Fire bypass	Zone
572 24 Hour zone bypass	Zone

Table 8–23: Contact ID Event Definition Codes (continued)

EVENT	DATA TYPE
573 Burg. Bypass	Zone
574 Group bypass	User
575 Swinger bypass	Zone
576 Access zone shunt	Zone
577 Access point bypass	Zone
578 Vault Bypass	Zone
579 Vent Zone Bypass	Zone
TEST / MISC.	
Test/Misc. -600, 610	
601 Manual trigger test report	Zone
602 Periodic test report	Zone
603 Periodic RF transmission	Zone
604 Fire test	User
605 Status report to follow	Zone
606 Listen-in to follow	Zone
607 Walk test mode	User
608 Periodic test - System Trouble Present	Zone
609 Video Xmitter active	Zone
611 Point tested OK	Zone
612 Point not tested	Zone
613 Intrusion Zone Walk Tested	Zone
614 Fire Zone Walk Tested	Zone
615 Panic Zone Walk Tested	Zone
616 Service Request	Zone
Event Log -620	
621 Event Log reset	Zone
622 Event Log 50% full	Zone
623 Event Log 90% full	Zone
624 Event Log overflow	Zone
625 Time/Date reset	User
626 Time/Date inaccurate	Zone
627 Program mode entry	Zone
628 Program mode exit	Zone
629 32 Hour Event log marker	Zone
Scheduling -630	
630 Schedule change	Zone
631 Exception schedule change	Zone
632 Access schedule change	Zone
Personnel Monitoring -640	
641 Senior Watch Trouble	Zone
642 Latch-key Supervision	User
Misc. -650, 700, 900	
651 Reserved for ADEMCO Use	Zone
652 Reserved for ADEMCO Use	User
653 Reserved for ADEMCO Use	User
654 System Inactivity	Zone
703 Auxiliary #3	Zone
704 Installer Test	Zone
750-789 "User Assigned"	
796 Unable to output signal (Derived Channel)	Zone
798 STU Controller down (Derived Channel)	Zone
900 Download Abort	Downloader ID
901 Download Start/End	Downloader ID
902 Download Interrupted	Downloader ID
910 Auto-close with Bypass	Zone

Table 8–23: Contact ID Event Definition Codes (continued)

EVENT	DATA TYPE
911 Bypass Closing	Zone
912 Fire Alarm Silence	
913 Supervisory Point test Start/End	User
914 Hold-up test Start/End	User
915 Burg. Test Print Start/End	
916 Supervisory Test Print Start/End	
917 Burg. Diagnostics Start/End	Zone
918 Fire Diagnostics Start/End	Zone
919 Untyped diagnostics	Zone
920 Trouble Closing (closed with burg. during exit)	User
921 Access Denied Code Unknown	User
922 Supervisory Point Alarm	Zone
923 Supervisory Point Bypass	Zone
924 Supervisory Point Trouble	Zone
925 Hold-up Point Bypass	Zone
926 AC Failure for 4 hours	Zone
927 Output Trouble	Zone
928 User code for event	User
929 Log-off	User

8.5.5 MX8000/685 System Messages

The MX8000 generates messages to the automation computer for system generated troubles/restores and operator generated troubles/restores while operating using the 685 automation protocol. These messages are listed in Table 8–24.

8.6 CAPS Automation Protocol

The CAPS automation protocol is the same as the 685 except in the case of the 4x2 and 4x2 Express. When using 4x2 and 4x2 Express with the CAPS automation protocol, the output protocol to the computer is as shown in Figure 8–5.

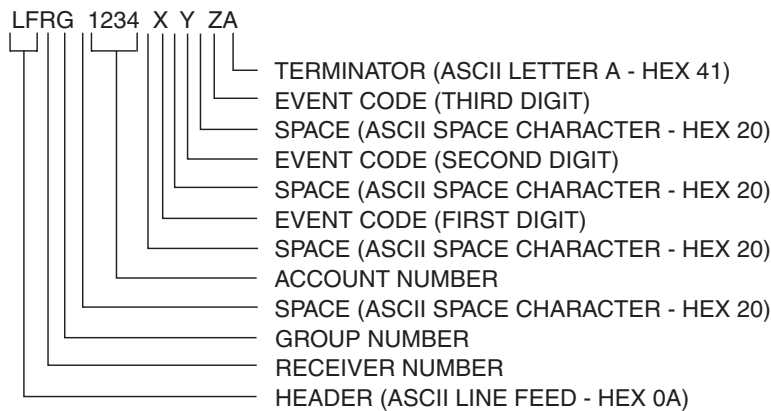

Figure 8–5: CAPS 4x2 and 4x2 Express Protocol

The 3-digit event code (XYZ) is a calculated value between 000 and 255. The XYZ value is calculated as follows:

$$XYZ = (16 \times \text{Event Code}) + \text{Zone Identifier}$$

Table 8–24: MX8000/685 System Messages

Printer Message	685 Automation Output	
MX8000 INITIATED MESSAGES		
LC Line Fault Event	LINE XXXX XXXX 7 (5 = normal, 1 new fault, 3 = line restore, 6 = previously reported)	
LC Line Fault Restore Event	LINE XXXX XXXX 7 (5 = normal, 1 new fault, 3 = line restore, 6 = previously reported)	
Main Computer Trouble	RCVA 1555 5555 7	
Main Computer Trouble Restore	RCVA 3555 5555 7	
Bkup Printer Off Line	RCVA 5155 5555 7	
Bkup Printer Paper Out		
Bkup Printer Restore	RCVA 5355 5555 7	
Bkup Computer Trouble	RCVA 5515 5555 7	
Bkup Computer Restore	RCVA 5535 5555 7	
Main Printer Off Line	RCVA 5551 5555 7	
Main Printer Paper Out		
Main Printer Restore	RCVA 5553 5555 7	
AC Trouble	RCVA 5555 1555 7	
AC Trouble Restore	RCVA 5555 3555 7	
DC Input Low	RCVA 5555 5155 7	
Battery Low		
DC Input Low Restore	RCVA 5555 5355 7	
Battery Low Restore		
Message Queue Warning	RCVA 5555 5551 7	
Message Queue Full (See Important Note below)		
Message Queue Warning Restore	RCVA 5555 5553 7	
Message Queue Full Restore		
No Data Received	RCVB 5555 5155 7	
0 Length Blk		
No ACK		
Time Out		
Illegal Specifier		
Undefined Event		
Unsupported Event		
Unsupported Fmt		
Possible Incomplete Call		
Event Unsupported By Automation		
Corrupted Data		
Communication Error, Panel Requested Re-send		
OPERATOR INITIATED MESSAGES		
System Power Up		RCVB 1555 5555 7
System Date Changed User	RCVB 5555 5515 7	
System Time Changed User		
Time Adjusted For DST		

IMPORTANT NOTE: A "Message Queue Full" system message indicates that the MX8000 call event buffer is full and the MX8000 receiver has gone into a "Stop Answering Mode". This has occurred because either the printer or automation system has failed and the MX8000 began logging events internally (eventually filling up its internal buffer). **No more calls will be accepted until the MX8000 can free up part of its event buffer to either the printer and/or automation system** (depending upon how the system has been configured).

8.7 FBII CP-220 Automation Protocol

8.7.1 3x1, 4x1, and 4x2 Automation Protocols

When the MX8000 receives a 3x1, 4x1, and 4x2 transmission operating in the CP-220 mode, the output protocol to the computer is as shown in Figure 8-6.

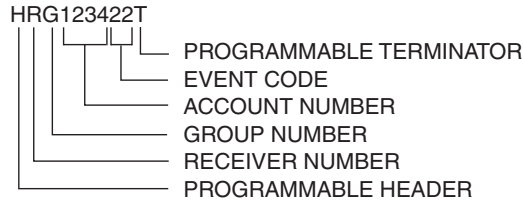

Figure 8-6: CP-220 3x1, 4x1, 4x2 Protocol

8.7.2 Acron 11 Digit with Zero or Space

When the MX8000 receives an Acron fast transmission while operating in the CP-220 mode, the output protocol to the computer is as shown in Figure 8-7.

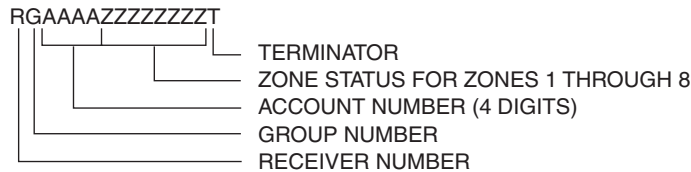

Figure 8-7: CP-220 Acron 11 Digit Protocol

When a 3-digit account number is received, the MX8000 will send a zero or a space in place of the first digit of the account number, dependent on the setting programmed into the receiver.

When in Radionics or ADEMCO modes, the MX8000 will send an illegal format message to the computer since it does not accept this format when in these modes.

8.7.3 FBII Superfast

When the MX8000 receives an FBII Superfast transmission while operating in the CP-220 mode, the output protocol to the computer is as shown in Figure 8-8.

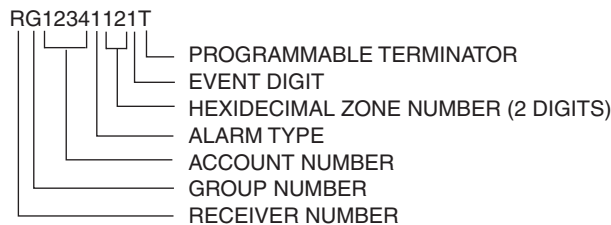

Figure 8-8: CP-220 FBII Superfast Protocol

A space will be sent as the zone digit any time that the MX8000 receives a zero or letter a for the zone digit.

8.7.4 CP-220 Contact ID

When the MX8000 receives a Contact ID[®] (also referred to as Point ID – PID) transmission while operating in the CP-220 mode, the output protocol to the computer is as shown in Figure 8-9.

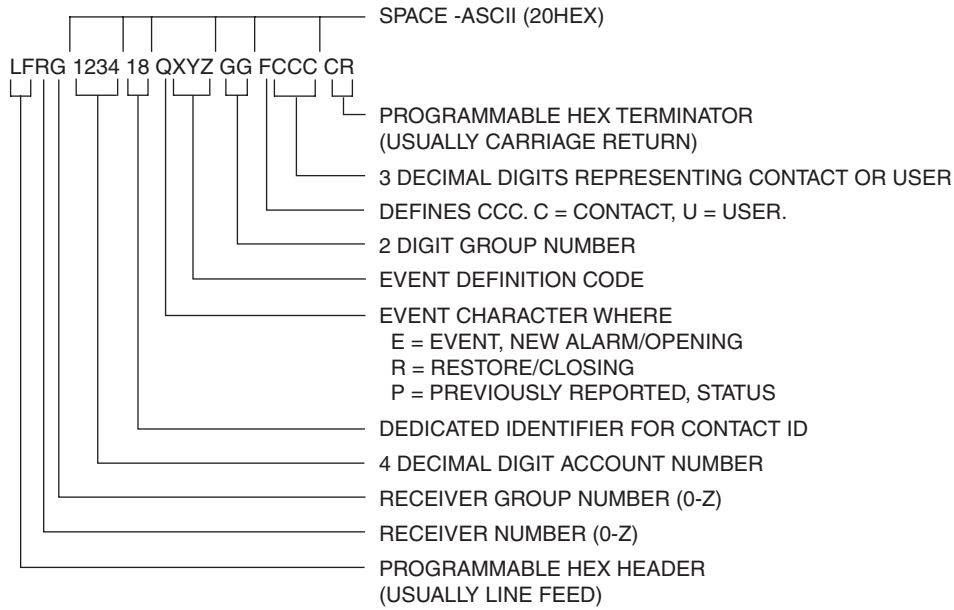

Figure 8–9: CP-220 Contact ID Protocol

ADEMCO DTMF formats will not transmit a true TouchTone “0” therefore, all “A”s are converted to 0 (zero) prior to output. The code string contains spaces at the points shown in Figure 8–9.

Contact ID Event Definition Codes are provided in Table 8–23.

8.7.5 CP-220/Silent Knight

The MX8000 processes 3 Silent Knight FSK protocols when operating in the CP-220 Mode. The formats are Format 0, Format 1 (FSK1) and Format 6 (FSK 2). These protocols are discussed in the following paragraphs.

FORMAT 0

When the MX8000 receives a Silent Knight Format 0 transmission, the output protocol to the computer is as shown in Figure 8–10.

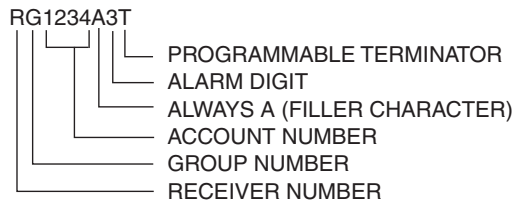

Figure 8–10: CP-220/Silent Knight Format 0

FORMAT 1

When the MX8000 receives a Silent Knight Format 1 (FSK 1) transmission, the output protocol to the computer is as shown in Figure 8–11.

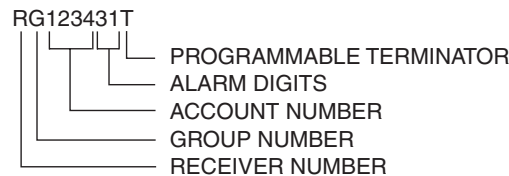

Figure 8–11: CP-220/Silent Knight Format 1 (FSK 1)

A space will be sent as the zone digit any time that the MX8000 receives a zero or letter a for the zone digit.

FORMAT 6

When the MX8000 receives a Silent Knight Format 6 (FSK 2) transmission, the output protocol to the computer is as shown in Figure 8–12.

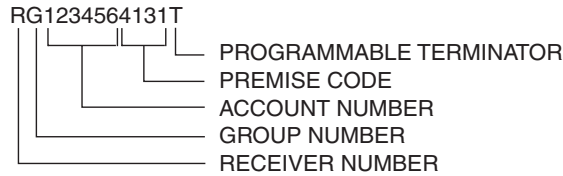

Figure 8–12: CP-220/Silent Knight Format 6 (FSK 2)

8.7.6 MX8000/CP-220 System Messages

The MX8000 generates messages to the automation computer for system generated troubles/restores and operator generated troubles/restores while operating using the CP-220 automation protocol. These message are listed in Table 8–25.

Table 8–25: MX8000/CP-220 System Messages

Printer Message	CP-220 Automation Output	Printer Message	CP-220 Automation Output
Main Computer Trouble	r0RCVA11t	LC Line Fault Event	rgLINE1xt (x = line #)
Bkup Computer Trouble		LC Line Fault Restore Event	rgLINE3xt (x = line #)
Main Printer Off Line	r0RCVA14t	No Data Received	rgRCVB16t
Main Printer Paper Out		0 Length Blk	rgRCVB26t
Bkup Printer Off Line		No ACK	
Bkup Printer Paper Out	Time Out		
AC Trouble	r0RCVA15t	Illegal Specifier	
DC Input Low	r0RCVA16t	Undefined Event	
Battery Low		Unsupported Event	
Main Computer Trouble Restore	r0RCVA31t	Unsupported Fmt	
Bkup Computer Restore		Possible Incomplete Call	
Main Printer Restore	r0RCVA34t	Event Unsupported By Automation	
Bkup Printer Restore		Corrupted Data	
AC Trouble Restore	r0RCVA35t	Communication Error, Panel Requested Re-send	
DC Input Low Restore	r0RCVA36t	Expander Trouble	rgRCVB5xt (x = line #)
Battery Low Restore		Slave Expander Trouble	
System Power Up	r0RCVB01t	Expander Trouble Restore	rgRCVB7xt (x = line #)
System Warm Boot User		Slave Expander Trouble Restore	
Message Queue Warning	r0RCVB18t	User Log In: User	r0hhhh17t (hhhh = user #)
Message Queue Full (See Important Note below)		User Log Out: User	r0hhhh27t (hhhh = user #)
Message Queue Warning Restore	r0RCVB38t		
Message Queue Full Restore			
Flash Checksum Error	r0RCVB44t		

IMPORTANT NOTE: A "Message Queue Full" system message indicates that the MX8000 call event buffer is full and the MX8000 receiver has gone into a "Stop Answering Mode". This has occurred because either the printer or automation system has failed and the MX8000 began logging events internally (eventually filling up its internal buffer). **No more calls will be accepted until the MX8000 can free up part of its event buffer to either the printer and/or automation system** (depending upon how the system has been configured).

8.8 SK9000 Protocol

The following sections describe the computer protocol.

8.8.1 Data String Description And Special Characters

Table 8–26: Data String Description

Data Element	Byte(s) Occupied	Description
Identifier	1	The first byte of a message is the identifier. This byte is always \$01 or \$27. \$01 = a system message \$27 = a call from a panel
Date	2-7	The next 6 bytes are the date in MMDDYY format, where each byte contains the ASCII code for the digits 0-9.
Separator	8	The byte after the date is a separator. It will always be \$22.
Time	9-12	The time, in the 24-hour military format, at which the MX8000 receives the message, occupies bytes 9-12. Each byte contains the ASCII code for the digits 0-9.
Separator	13	The separator \$22 occupies byte 13. The actual call or message data follows this byte.
Format number	14	In a call, byte 14 is the format number, which indicates the format of the line card the call was received in.
Line card number	15	Byte 15 is the line card hunt group number. In some cases you may need to decode the hunt group number. If the hunt group is set to 00 then the number sent in byte 15 is equal to the line card number. (See section 5.4.2.5 for more information.)
Separator	16	Byte 16 is a separator that precedes the actual call or message data. The data will be \$05.
Account #	Variable, beginning at position 17.	Can be 1-8 bytes long. ASCII codes for the digits 0-9 and characters A-Z are acceptable data.
Separator	Variable	The separator \$22 separates the account number from the first event.
Event Data (Alarms and System Messages)	Variable	Alarms can be up to 11 characters. Multiple alarms are separated by \$22 (ASCII code for the double quotation mark). System messages, (indicated when the first byte of the message is \$01), are always sent separately. For example, if two line cards have a problem at the same time, the MX8000 will send one message for each line card.
Validation Byte (V-Byte)	1 byte. Follows event data.	Error-check byte. (See section 8.8.6 for more information.)
End of Message Indicator (carriage return)	1 byte. Last byte in call.	This byte is always \$0D and indicates the end of the message.

Table 8–27: Special Characters Used in the Protocol

Hex Value	Meaning
\$27	If this character is the first byte in a string, the data that follows is an actual call from a subscriber (rather than a system message).
\$01	If this character is the first byte in a string, the data that follows is a system message (rather than a call from a panel).
\$22	Separator. Separates the date from the time; separates the time from the data that follows; separates multiple events occurring in the same message.
\$05	Separates header information from account # in messages from subscribers.
\$23	Bad data. This marks a block of questionable data.
\$21	Bad data mixed with good data in the same call. This marks a block of good data that follows a block of questionable data.
\$2C	Long call; more data to come for this call in next block.
\$0D	Indicates end of message.
\$2A	Listen in begins.

8.8.2 Calls From Panels

The basic format of a message is shown in the example below. For a complete description of each data element, see Table 8–26.

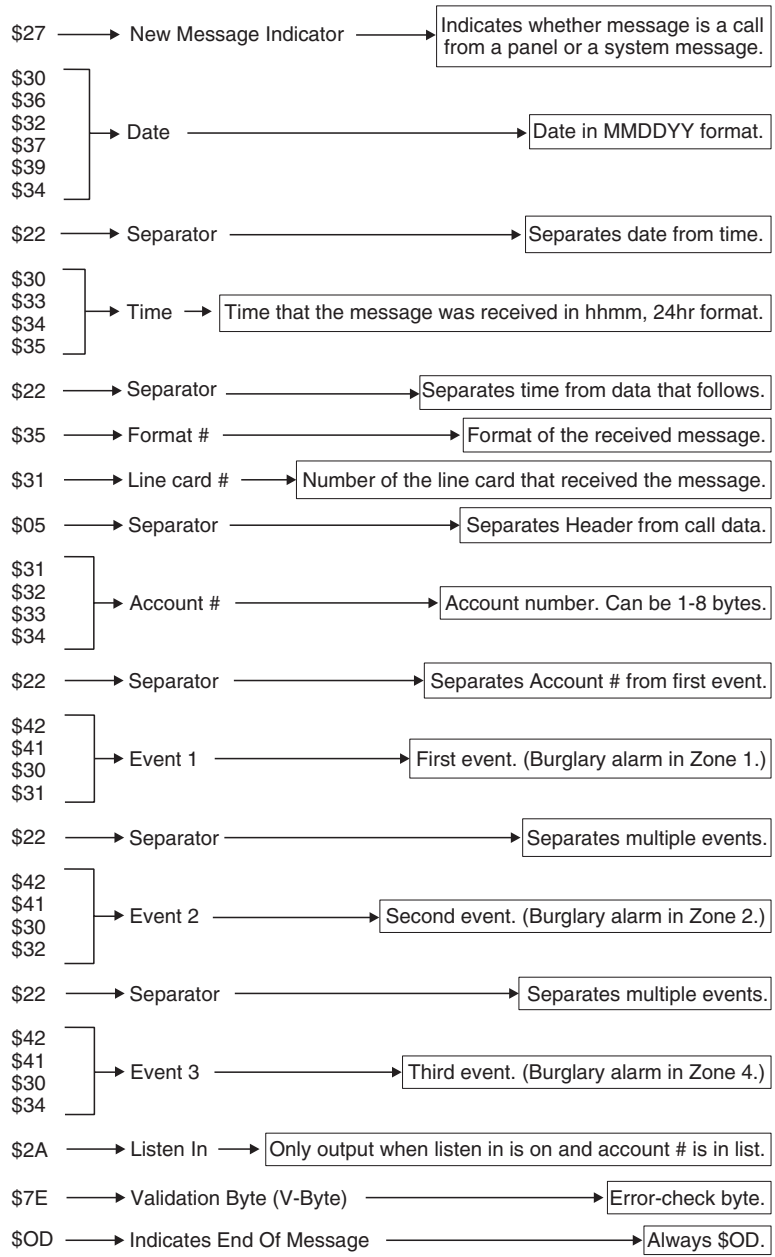

Figure 8–13: SK9000 Example Message

8.8.3 Long Calls

The MX8000 can send up to 70 bytes per message to an automation computer. When event data is more than 70 bytes, the MX8000 breaks up the data into 70-byte chunks ending in a separator \$2C, a V-Byte, and the end of message indicator \$0D.

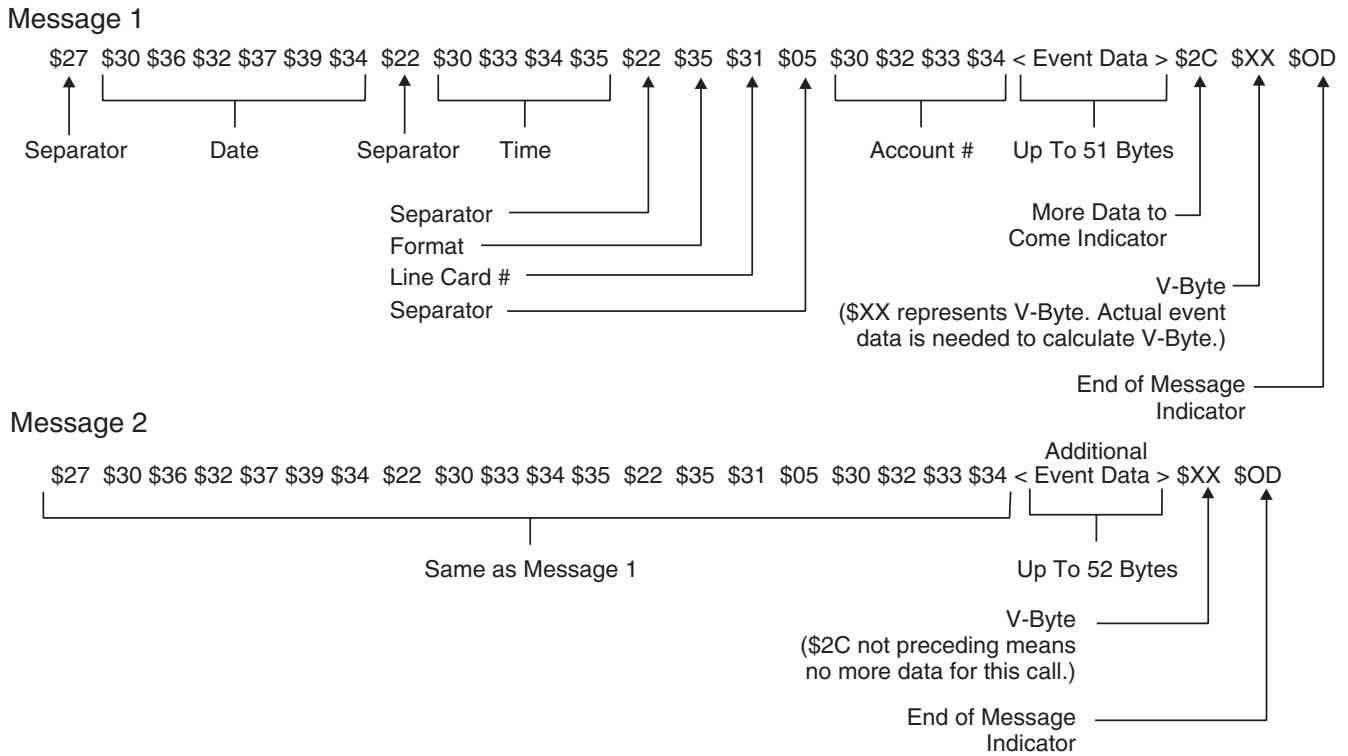

Figure 8–14: Long Event Data

8.8.4 Bad Data

When the MX8000 receives data it cannot interpret, it precedes the data with \$23. The MX8000 accepts 20 characters of bad data. This allows operators to determine, if possible, the account number of the panel sending the bad data for troubleshooting purposes. Causes for bad data include: Noise on the telephone line and non-matching first and second rounds of data.

A single message could include more than one string of bad data, indicating, for example, that the first and second rounds of data did not match each other.

8.8.5 Good Data with Bad Data

Good data can be mixed with bad data in one call. \$21 indicates good data after bad. Good data always starts with an account number.

Note: *That this would be the case even if the account number had already been passed before the bad data occurred.*

8.8.6 Validation Byte (V-Byte)

The V-Byte always precedes the end of message character. Each data string has this byte as the second to the last byte. The V-Byte is the only error-checking of data the SK9000 protocol performs. The V-Byte calculation is shown below. The result of the calculation should equal the transmitted V-Byte value.

1. Set the V-Byte comparison byte to zero.
2. Add the first (or next) byte of the message to the V-Byte comparison byte.
3. Clear bit 7 of the V-Byte comparison byte.
4. Set bit 6 of the V-Byte comparison byte.
5. Repeat steps 2, 3, and 4 until the last byte of event data (that is, up to and including the byte preceding the V-Byte). The range of the V-Byte is \$40 to \$7F.

8.8.7 System Messages

The character \$01 at the beginning of a data string indicates that the MX8000 is reporting its internal status. A sample system message is shown in Figure 8–15. Table 8–28 lists the possible system messages and what format the data can take.

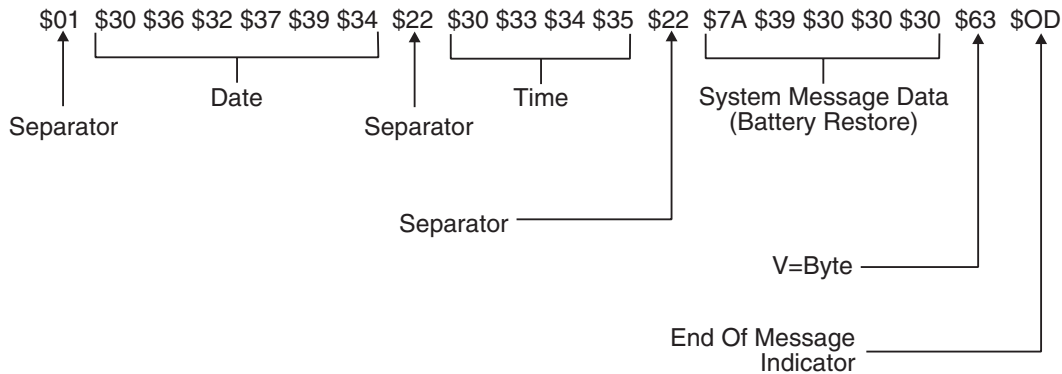

Figure 8–15: System Message

Table 8–28 lists the system messages. Some system messages are one byte. Other messages are always sent with other information, such as the line card number. All system messages are sent separately. For example, if two line cards have a problem at the same time, the MX8000 will send one message for each LinePort. The V-Byte and a carriage return (\$0D) always follow system messages.

Table 8–28: System Messages

SYSTEM MESSAGE	MEANING (PRINTED MESSAGE)
\$77	AC LOST
\$78	AC RESTORE
\$7B	COMPUTER TROUBLE
\$7D	COMPUTER RESTORE
\$70 + 2 bytes for line card number	LINE CARD TROUBLE
\$72 + 2 bytes for line card number	LINE CARD TRBL RSTR
\$71 + 2 bytes for line number	PHONE LINE TROUBLE
\$73 + 2 bytes for line number	PHONE LINE RESTORE
\$79 + 4 bytes indicating MX8000. (See Note below.)	BATTERY TROUBLE MX8000
\$7A + 4 bytes indicating MX8000.	BATTERY RESTORE MX8000
\$7F + 2 bytes indicating the <i>number of the log on code</i> (not the code itself).	LOG ON OPERATOR
\$7E + 2 bytes indicating the <i>number of the log off code</i> (not the code itself).	LOG OFF OPERATOR

Note: The 4 bytes are the ASCII coded values for the model numbers “MX8000”. For example, “\$79 \$39 \$38 \$30 \$30” means “battery trouble with MX8000”.

8.8.8 Communication from a Computer to the MX8000

8.8.8.1 ACKing and NACKing Data

The computer must respond to messages sent by the MX8000 with an ACK or NACK.

An ACK (\$06) is sent when the computer’s V-Byte calculation agrees with the V-Byte value sent in the message and the general format of the message looks correct (for example, the last byte was \$0D).

A NACK (\$15) is sent whenever the computer suspects an error in the transmission of the message. The computer must respond within one timeout period of receiving the last byte of a message. (See *Ack Time (Acknowledge Time)* on page 5–18)

The MX8000 ignores any other communication from the computer when it is awaiting ACKing or NACKing. Generally, after two NACKs or two timeout periods of no response from the computer, the MX8000 generates a “computer trouble” message.

- If the computer ACKs the data, the MX8000 will send any additional data in its buffer.
- If the computer NACKs the data, the MX8000 will immediately re-send the data.
- If the computer NACKs a second time, the MX8000 will generate a computer trouble message.
- If the computer does not respond the second time the MX8000 sends the data, the MX8000 will generate a computer trouble message.
- If a backup automation device (printer or secondary automation system) is configured, the unacknowledged message will be sent to the device.

8.8.8.2 Link Test

The automation computer may send a Link Test request to the MX8000 receiver to verify the communication link between the receiver and the automation computer. The MX8000 receiver will respond to each Link Test (\$00) request with a NACK.

8.9 ITI Generic Computer Format

The ITI Generic Computer Output Format is designed to pass reported information through an RS-232 port to communicate with an automation computer. This format consists of four types of Generic Records--a Report Record, a Log Record, a Test Record, and an Okay Record.

8.9.1 Convention Used In This Section

An ITI digit in this section is an ASCII representation of a number from 0 to 61 as follows:

Table 8–29: Number and ITI Digit Equivalent

Number	Represented by ITI Digit
0 - 9	0 - 9
10 - 35	A - Z
36 - 61	a - z

8.9.2 Report Record

A report record is an alarm report from a control panel to the receiver.

The following is a general description of the information contained in a report record:

<\$0A><"1"><"B"><"1"><\$6A><"2345"><"8"><"b"><"45"><"A"><\$0D>

Table 8–30: Report Record Components

Character	Byte	Description
<\$0A>	0	ASCII (0A hex) line feed character that marks the beginning of a record.
<"1">	1	Receiver ID digit. See Table 8–29 for value range.
<"B">	2	Phone line number digit. See Table 8–29 for value range.
<"1">	3	Most significant digit of account number. For example, A in account AB-CDE.
<\$6A>	4	Control panel type/zone attribute code. See 8.9.2.1 for more information.
<"2345">	5-8	Lower 4 digits of the account number. For example, B-CDE in account AB-CDE.
<"8">	9	Group number. See Table 8–29 for value range.
<"b">	10	User ID number. Will report 0 when a user number is not applicable. See Table 8–29 for value range.
<"45">	11-12	Zone number. Two ASCII digits 00 - 99, A = 100, C = 110
<"A">	13	Alarm condition. See Table 8–34 for alarm codes and descriptions.
<\$0D>	14	ASCII (0D hex) carriage return marking the end of the record.

8.9.2.1 Control Panel Type and Zone Attribution Byte

Byte 4 (see Table 8–30) of the report record is divided into upper and lower nibbles. The upper nibbles (4 most significant bits) contain the code indicating the panel type.

Table 8–31: Upper Nibble Description

Upper Nibble Value	Description
2	Unknown Control Panel.
3	Non-ITI format
4	SX-III or SX-IVA
5	SX-IVB
6	SX-V
7	All other ITI panels.

The lower nibble (4 least significant bits) contains the code describing the zone attributes (unique with ITI panels). The definition of this field varies depending on which ITI panel the call was generated from. Refer to the installation manual of the ITI panel you wish to communicate with for communication specifications. If the upper nibble is 3 (non-ITI format), the lower nibble is used to identify the panel.

Table 8–32: Lower Nibble Description

Lower Nibble Value	Description
0	Anything not listed below
1	Slow 3/1 format
2	Fast 3/1 format
3	Slow 3/1 extended format
4	Fast 3/1 extended format
5	Slow 4/1 format
6	Fast 4/1 format
7	Slow 4/2 format
8	Fast 4/2 format
9	Radionics 3/1 hex format
\$A	Radionics BFSK

8.9.2.2 Extended Panel ID Codes

When XID is set to \bar{Y} in programming mode (see Section 5.3.3.5 page 5–19) the extended panel ID replaces the control panel type as described in Section 8.9.2.1.

Table 8–33 lists the XID codes (both the Hex and the ASCII character) for the ITI Generic computer output.

Table 8–33: Extended Panel ID Codes (XID)

XID Code		Panel Type
Hex Character	ASCII Character	
\$40	@	SX-III
\$50	P	SX-IVB
\$60	'	SX-V
\$70	p	Other ITI panel
\$72	r	SX-V Special
\$73	s	Commander
\$74	t	RF Commander
\$75	u	CareTaker +
\$77	w	Commander 2000
\$78	x	Security Pro 4000
\$79	y	UltraGard
\$7A	z	European Commander
\$7B	{	Simon
\$7E	~	New Panels

8.9.2.3 Alarm Codes

Table 8–34 lists the alarm codes used in byte 13 of the report record, and a description of the alarm codes.

Table 8–34: Alarm Code and Description

Alarm Codes	Description
A	Alarm
B	Bypass
C	Closing Report
D	Dial out audio alarm
E	Exit fault
G	One-ring audio report
H	AC restore (non-ITI panels only)
I	Improper security code
J	Trouble
K	Key-chain access
L	Low battery
O	Opening report
P	Phone test
Q	AC failure (non-ITI panels only)
R	Cancel
S	Supervisory
T	Tamper alarm
U	Burglary (non-ITI panels only)
V	Instant audio alarm
W	Restoral
X	Medical/auxiliary emergency (FonSafe)
x	Medical/auxiliary emergency with audio verification (FonSafe)
Y	Police emergency (FonSafe)
y	Police emergency with audio verification (FonSafe)
Z	Fire emergency (FonSafe)
z	Fire emergency with audio verification (FonSafe)

8.9.3 Log Record

If Log Record (Log Rec) is enabled (see Section 5.3.3.5 page 5–19), a pair of phone log records surrounds all report records generated by the reporting panel. The unused data field of the log record is filled with six "NoData" characters (see Section 5.3.3.5 page 5–19).

The following is an example of how a log record surrounds a report record:

<\$0A><"1"><"1"><"0100"><"000000"><"N"><\$0D>	New Log Record
<Report Record>	Report Record
<Report Record>	Report Record
<\$0A><"1"><"1"><"0100"><"000000"><"F"><\$0D>	Final Log Record

Table 8–35 lists the components of a log record and their description.

Table 8–35: Log Record Components and Description

Character	Description
<\$0A>	Start or record indicator (line feed).
<"1">	Receiver ID number.
<"1">	Phone line number.
<"0100">	Reference number, equals four ASCII bytes ranging from 0001-9999.
<"000000">	Six No Data characters. Valid characters are: 0-9, A-Z, a- z, Space, :, -, _ , , , & , * , # , ? , E _c . See Section 5.3.3.5 page 5–19.
<"N">	New or start of log record.
<"F">	Final or end of log record.
<\$0D>	End of record indicator (carriage return).

8.9.4 Test Record

A test record is sent when panel date/time is updated.

The following is an example of a test record:

```
<$0A><"IT IRCV 234A"><$0D>
```

Table 8–36: Test Record Components and Description

Character	Description
<\$0A>	Start of record (line feed).
<"IT IRCV 234A">	Predefined test record string. The predefined test string is automatically set when ITI Generic format is chosen to communicate with automation computer.
<\$0D>	End of record indicator (carriage return).

8.9.5 OKAY Record

When the automation computer sends a supervisory character to the MX8000 receiver, the receiver will return with an OKAY record. An OKAY record (heartbeat) is sent periodically to the automation computer. How often the OKAY record is sent is set through programming (see Section 5.3.3.5 page 5–17).

Note: *The supervisory character is programmable. See Section 5.3.3.5 page 5–19.*

The following is an example of an Okay record:

```
<$0A><"00 OKAY @"><$0D>
```

Table 8–37: Okay Record Components and Description

Character	Description
<\$0A>	Start of record (line feed).
<"00 OKAY @">	Predefined okay record string. The predefined okay record string is automatically set when ITI Generic format is chosen to communicate with automation computer.
<\$0D>	End of record indicator (carriage return).

8.9.6 ACKing and NACKing Data

After the end of message byte (<0Dh>) is sent by the receiver, the automation computer will respond with an ACK (<\$06>) or NACK (<\$15>). This response can be delayed between 1 byte time (depending on the baud rate) and the ACK timeout period. See Section 5.3.3.5 page 5–18.

If the receiver doesn't get an ACK within the ACK timeout period or receive a NACK from the automation computer, it will re-transmit the data.

After two NACKs or two ACK timeouts the receiver will generate a **Computer Trouble** message. When a computer trouble message is generated, the receiver will continually send a heartbeat until it receives an ACK from the automation computer. When communication is restored, a Computer Trouble Restore message will be generated.

8.10 ITI Computer Interface Format

ITI Computer Interface format consists of four types of records; report record, test record supervisory record, and log record (see Table 8–39).

8.10.1 Convention Used In This Section

An ITI digit in this section is an ASCII representation of a number from 0 to 61 as follows:

Table 8–38: Number and ITI Digit Equivalent

Number	Represented by ITI Digit
0 - 9	0 - 9
10 - 35	A - Z
36 - 61	a - z

8.10.2 General Record Structure

Each record begins with "<|["><Record Type> field (see Table 8–39 for record identifiers) and ends with a "<|]"><Cksum/Ctrl> field. Any fields within a record may be included in an individual record as needed.

A record is made up of fields of data (in varying lengths), and each field within a record begins with a "<|]"> character. The "<|]"> is followed by a field identifying character. Individual field identifiers are unique to the specific record where they are contained. For example, a |L field in a report record has a different meaning than an |L field of a test record and so on. There is no specific order to the fields of a record, with the exception that it will begin with the record type and end with a checksum/control field.

After the checksum/control field each record is terminated with a carriage return (<\$0D>).

Table 8–39: Type of Record Identifiers

Field Identifier	Definition
[R	Report record
[T	Test record
[S	Supervisory record
[L	Log record

The following is a generic example of a transmitted message record:

```
<|["><Record Type><Info fields...>"|]"><Cksum/Ctrl><$0D>
```

Table 8–40: Record Components

Character	Description
<" [">	Start of record indicator.
<Record Type>	Record type. See Table 8–39.
< Info fields...>	Information fields. See Table 8–42.
<"]">	End of information fields indicator.
<Cksum/Ctrl>	Checksum/control field. See Section 8.10.7.
<\$0D>	End of record indicator.

8.10.3 Report Record

A report record is generated when a control panel calls into the receiver for any reason.

The following is an example report record (see also Table 8–41):

```
<"|["><"R"><"|IA1"><"|LB"><"|A123456"><"|V55600"><"|D0514"><"|T1019"><"N0005"><"|Z1"><"|CA"><"|]"><Cksum/Ctrl><$0D>
```

Table 8–41 lists the components of a report record and their description.

Table 8–41: Report Record Components and Description

Character	Description
<" [">	Start of record indicator.
<R>	Report record identifier.
<" IA1 ">	Unit ID = A, followed by receiver ID = 1.
<" LB ">	Line Card #, B = 11. Acceptable values are 0-9, A (= 10), B (=11), C (=12).
<" A123456 ">	Account Number.
<" V55600 ">	Panel (see Table 8–43) and revision number. In this example the panel = SX-V and the revision is 5600.
<" D0514 ">	Date of the report in mmdd format. mm = Month, dd = Day
<" T1019 ">	Time of report in hhmm format. hh = Hour, mm = Minutes
<"N0005">	Reference number. See Section 4.6.3 0001-9999
<" Z1 ">	Zone number. One to four alphanumeric characters are acceptable values.
<" CA ">	Condition code indicating the nature of the reported message. See Table 8–28.
<"] ">	End of information fields indicator.
<Cksum/Ctrl>	Checksum/control field. See Section 8.10.7.
<\$0D>	End of record indicator.

8.10.3.1 Information Field Identifiers

The following characters signify which data is contained in an information field:

Table 8–42: Information Field Identifiers

Field Identifier	Description	Acceptable Values
I	System identifier. A unit ID (always an A) and the receiver ID digit. See 5.3.4.2 to set receiver ID.	"A" followed by 0-9.
O	Communication Lock (Comm-Lock) usage.	0 = Not Supported (4) 1 = Phone lock 2 = Central Station Lock 3 = No lock used
M	Audio (Listen-in) usage.	0 = Not Used (4) 1 = Instant mode 2 = Dial out mode 3 = One ring mode
L	Line Card number.	See Table 8–38 for acceptable values.
A	Account number.	Three to six alphanumeric characters. If the account is more than 6 characters the account will be truncated to the last six characters.
P	Protection level of panel.	Two bytes, the first indicates the previous protection level and the second indicates the current protection level.

Table 8–42: Information Field Identifiers (cont'd)

Field Identifier	Description	Acceptable Values
V	Panel type and revision.	One panel type code byte followed by a 4-digit revision number. See Table 8–43.
G	Group and attribute information.	Contact ITI for group and attribute information.
D	Date of report.	In mmdd format, where mm = month, and dd = day.
T	Time of report	In hhmm format, where hh = hour, and mm = minutes.
N	Reference number.	0001-9999. See also Section 4.6.3.
Z	Zone number.	One to four alphanumeric characters.
U	User number.	See Table 8–38 for acceptable values.
K	Dealer key numbers. For Commander 2000 only.	Values from 00-99.
S	CPU sub-unit number	Values from 0-9
C	Condition code indicating the nature of the reported message. See Table 8–28.	See Table 8–28 for condition code values.

8.10.3.2 Panel Type Characters

The following table lists the characters used for panel types and which panel they refer to:

Table 8–43: Panel Type Characters

Character	Panel Type
0	Unknown type
3	SX-III or SX-IVA
4	SX-IVB
5	SX-V
9	FonSafe
A	Commander
B	SX-V Special
C	Magnetic card reader
D	Euro Commander
E	Security Pro 4000
K	HaborGard
M	UltraGard
N	Network Security
P	Pin Point
R	RF Commander
S	Commander 2000 or LifeGard
T	CareTaker +
V	Protector
Z	Nutone

Character	Panel Type
a	3/1
e	3/1 extended
i	4/1
m	4/2
r	Radionics BFSK
s	SIA DSC
t	Contact ID
v	ADEMCO TouchTone
w	Acron TouchTone
x	Westec TouchTone
y	ADEMCO DTMF 4/2
z	ADEMCO DTMF 4/1
#	ADEMCO High Speed (SIA D1)
\$	FSK 0
%	FSK 1
&	FSK 2
(FBI 4/3/1

8.10.3.3 Condition Codes

Condition codes are a one-digit character that indicates the nature of the call from a control panel to the receiver.

Table 8–44 lists the different condition codes and their descriptions:

Table 8–44: Condition Codes and Descriptions

Condition Code	Description
A	Alarm
B	Bypass
C	Closing Report
E	Exit Fault
F	Force Arm
G	Burglary (non-ITI panels only)
H	AC Restore (non-ITI panels only)
I	Improper Security Code
J	Trouble
L	Low battery
M	Medical/Auxiliary Emergency
N	Fire Emergency
O	Opening Report
P	Power Failure (non-ITI panels only)
Q	Police Emergency
R	Restoral
S	Supervisory
T	Tamper
U	Status Report (non-ITI panels only)
X	Cancel
Z	Phone Test
c	Key Access Closing Report
o	Key Access Opening Report

8.10.4 Test Record

A test record is sent when the panel date/time is updated.

The following is an example of a test record:

```
<" | [ "><"T"><" | IA1 "><" | D970514 "><" | T145056 "><" | V042097 "><" | L6.1 "><" | ] ">
<Cksum/Ctrl><$0D>
```

Table 8–45 lists the information fields contained in a test record and their descriptions:

Table 8–45: Test Record Information Fields and Descriptions

Character	Description	Acceptable Values
I	System identifier. A unit ID (always an A) and the receiver ID digit. See 5.3.4.2 to set receiver ID.	"A" followed by 0-9.
D	Date	Current date in yymmdd format yy = year, mm = month, dd = day.
T	Time	Current time in hhmmss format hh = hours, mm = minutes, ss = seconds.
V	Software version	In date format.
L	ITIComp revision level.	Two digits separated by a decimal point.

8.10.5 Supervisory Record

When the automation computer sends a supervisory character to the receiver, the receiver will answer with a supervisory record. A supervisory record (heartbeat) is sent periodically to the automation computer. How often the supervisory record is sent is set through programming (see Section 5.3.3.5 page 5–17).

The following is an example of a supervisory record:

```
<" | [ "><"S"><" | IA1 "><" | D970514 "><" | T145056 "><" | V042097 "><" | L6.1 "><" | ] ">
<Cksum/Ctrl><$0D>
```

Table 8–45 lists the information fields contained in a test record and their descriptions.

8.10.6 Log Records

If Log Record (Log Rec) is enabled (see Section 5.3.3.5 page 5–19), a pair of phone log records surrounds all report records generated by the reporting panel. The unused data field of the log record is filled with six "NoData" characters (see Section 5.3.3.5 page 5–19).

The following is an example of how a log record surrounds a report record:

```
<" | [ "><"L"><" | IA1 "><" | L1 "><" | N0001 "><" | S970425080020 "><" | ] "><Cksum/Ctrl><$0D> Start Log Rec
<Report Record> Report Rec
<Report Record> Report Rec
<" | [ "><"L"><" | IA1 "><" | L1 "><" | N0001 "><" | E970425080110 "><" | ] "><Cksum/Ctrl><$0D> End Log Rec
```

Table 8–46 lists the information fields contained in a log record and their descriptions.

Table 8–46: Log Record Information Fields and Descriptions

Character	Description	Acceptable Values
I	System identifier. A unit ID (always an A) and the receiver ID digit. See 5.3.4.2 to set receiver ID.	"A" followed by 0-9.
L	Line Card number.	See Table 8–38 for accepted values.
N	Reference number.	0001-9999
S	Date and time.	YYMMDDhhmmss format where YY = Year, MM = Month, DD = Day, hh = hour, mm = minutes, dd = seconds.
E	Date and time.	YYMMDDhhmmss format where YY = Year, MM = Month, DD = Day, hh = hour, mm = minutes, dd = seconds.

8.10.7 Checksum/Control Field

The last field of every record is the checksum/control field. This field contains an upper case letter followed by four ASCII hexadecimal digits. Contained in these five characters are three controls to help guarantee data integrity between the receiver and the automation computer.

The first control is the Sequence Control Character (SCC). This is a letter code which cycles from "A" to "Z" continually, changing successively with each new record transmitted.

Note: If the receiver has to repeat a record in response to a NACK from the automation computer, the same SCC is sent both times.

The first digits sent (following the SCC) are the two least significant digits of an additive checksum for the record from the first "I" character up to and including the SCC. See Table 8–47.

The last two digits in the record are an XOR checksum. The XOR checksum starts with a value FFh. This value is XORed against the first byte in the record. The result is XORed against the next byte and so on, up through the SCC. See Table 8–47.

The following is an example of a checksum/control field:

|[X|]A49E0

Table 8–47: Checksum Verification Process

Character	ASCII Code	Additive Checksum	XOR Checksum
	7C	00 + 7C = 7C	FF ^ 7C = 83
[5B	7C + 5B = D7	83 ^ 5B = D8
X	58	D7 + 58 = 12F	D8 ^ 58 = 80
	7C	12F + 7C = 1AB	80 ^ 7C = FC
]	5D	1AB + 5D = 208	FC ^ 5D = A1
A	41	208 + 41 = 249	A1 ^ 41 = E0

8.11 US ASCII Character Code

The following table displays the US ASCII character its hexadecimal code equivalent.

Table 8–48: US ASCII Character Code

Character	Hex	Character	Hex	Character	Hex	Character	Hex	Character	Hex
NUL	00	DC4	14	(28	<	3C	Q/q	51/71
SOH	01	NACK	15)	29	=	3D	R/r	52/72
STX	02	SYN	16	*	2A	>	3E	S/s	53/73
ETX	03	ETB	17	+	2B	?	3F	T/t	54/74
EOT	04	CAN	18	'	2C	@	40	U/u	55/75
ENQ	05	EM	19	-	2D	A/a	41/61	V/v	56/76
ACK	06	SUB	1A	.	2E	B/b	42/62	W/w	57/77
BEL	07	ESC	1B	/	2F	C/c	43/63	X/x	58/78
BS	08	FS	1C	0	30	D/d	44/64	Y/y	59/79
HT	09	GS	1D	1	31	E/e	45/65	Z/z	5A/7A
LF	0A	RS	1E	2	32	F/f	46/66	[5B
VT	0B	US	1F	3	33	G/g	47/67	\	5C
FF	0C	SPACE	20	4	34	H/h	48/68]	5D
CR	0D	!	21	5	35	I/i	49/69	/	5E
S0	0E	“	22	6	36	J/j	4A/6A		5F
S1	0F	#	23	7	37	K/k	4B/6B	'	60
DLE	10	\$	24	8	38	L/l	4C/6C	{	7B
DC1	11	%	25	9	39	M/m	4D/6D		7C
DC2	12	&	26	:	3A	N/n	4E/6E	}	7D
DC3	13	'	27	;	3B	O/o	4F/6F	~	7E
						P/p	50/70	DEL	7F

Appendix A Programming Quick Chart

Table A-1: Programming Quick Chart

Program Mode Options	Choices	Choices	Choices	Choices	Comments			
General Options	Operation Mode	Manual			See Section 4.5 for description of modes of operation. See also Section 5.3.1.			
		Automatic						
		Log Only						
	Display Options	Language	English			See Section 5.3.2 for details.		
			español			Not available at this time.		
		Time Format	AMPM			12-hour clock. See Section 5.3.2.2 for details.		
			24Hr			24-hour clock. See Section 5.3.2.2 for details.		
		Date Format	MDY			See Section 5.3.2.3 for details. M = month, D = day, Y = year.		
			D-M-Y					
			Y-M-D					
		Day light Savings	Yes			See Section 5.3.2.4 for details.		
			No					
		ITI Options	Attempts	Yes or No			See Section 5.3.2.5 Affects printer and VFD output only.	
			CPU Time	Yes or No				
			CPU Type	Yes or No				
			Panel Rev	Yes or No				
			Arming Level	Yes or No				
		Format Config.	FSK1	Code			If "English" is selected then the printer and VFD output for calls of these formats will be text descriptions. If "Code" is selected then the printer and VFD output for calls of these formats will be the Code and Zone numbers. See Section 5.3.2.6 for step-by-step instructions.	
				English				
			BSFK	Code				
				English				
			SIA	Code				If "English" is selected, the printer and VFD output will be text. If "Code" is selected then the printer and VFD will display the SIA codes followed by zone or other information. See Section 5.3.2.6 for step-by-step instructions.
				English				
CID			Code	This option only affects the ADEMCO 8000 automation protocol output. If "English" is selected each event will be sent to the automation as two SIA events; the first with the two digit Group number and the second with the three digit ID number. If "Code" is selected, each event is sent as eleven digits; two digits Message type, one-digit Event Qualifier, three-digit Event Code, two-digit Group Number, and three-digit ID number. See Section 5.3.2.6 for step-by-step instructions.				
			English					

Table A-1: Programming Quick Chart (cont'd)

Program Mode Options	Choices	Choices	Choices	Choices	Comments
General Options (continued)	Display Options (continued)	Format Config. (continued)	PULSE	0 .. 9	
				0 .. F	
			SK9000	Packed	
				Unpacked	
			ACRON	Zero	
				Space	
		HISPEED	SIA		
			Hispeed		
		Hold last event	Yes		See Section 5.3.2.7.
			No		
		VFD Brightness	Off		Affects main menu display only. All other displays are always at maximum. See Section 5.3.2.8 for details.
			25%		
			50%		
			75%		
			MAX		
	Communication	Port Functions	Com1	Unused/Automation/Printer/	Rules for Port Configuration: 1. Functions in Brackets [] will not appear unless "Automation" is selected for Com1 function. 2. Functions in { } will not appear unless "Printer" is selected in Com1 or Par. 3. A function may be selected only once in the 3 ports (only one printer, only one Diag, and so on). 4. All ports may be configured "Unused".
			Com2	Unused/[Auto Bkp]/[Auto Bkp Prn]/[Print Bkp]/Diag/Printer	
			Par (Parallel)	Unused/[Auto Bkp]/Printer/Diag	
		Com Port 1	Baud	38400, 19200, 9600, 7200, 4800, 2400, 1200, 600, 300, 110	
			D (# Data Bits)	8, 7	
			S (# Stop bits)	1 or 2	
			P (Parity)	Even, Odd, No	
			PortMon	Yes, No	
			F (Flow Control)	Hdwr, None, Software	
			Init Str (Initialization String)		Enter ASCII characters for the Escape command sequence desired. For example: Set the page size or number of lines per page for a serial printer.
		Com Port 2	Same as Com 1		
		Par Port	Edit Init String		Enter or edit an Escape command sequence. For example: Set the page size or number of lines per page for a printer.
Clear Init String					

Table A-1: Programming Quick Chart (cont'd)

Program Mode Options	Choices	Choices	Choices	Choices	Comments	
General Options (continued)	Communication (continued)	Automation Cfg.	Format	CAPS, SK9000, ADEM 8000, ADEM 685, FBII 220, ITI Gen, ITIComp	See Section 5.3.3.5 for details.	
			Hex	Y (yes)	Feature is only available if ADEM 8000 or SK9000 automation protocol is selected.	
				N (no)		
			Heartbeat	Y (yes)		
				N (no)		
			Time (of heartbeat)	10-600 seconds		
			Ack timeout	1-120 seconds		
			CFG	Term Char = 013	Feature is only available if ADEMCO 685, FBII CP-220, or CAPS ONLY is selected. Allows automation characters to be entered.	
				Head Char = 010		
				ACK Char = 006		
				NACK Char = 021		
				TR = 005		
				TH = 084		
			SEP	Y = Enabled	Only visible if SK9000 format selected. Sets account separator to hex 05 or 2E.	
				N = Disabled		
		ITI	Log Records	Y = Enabled	Only visible if ITI Gen or ITIComp format is selected.	
				N = Disabled		
			Enable Ext ID	Y = Enabled		
				N = Disabled		
			Super Character			
			No Data Character			
		Generic Revision	6.1			
			6.2			
		Annunciator Configuration	Printer	Yes or No	See Section 5.3.3.6 for details. Yes = alert on trouble indication	
			Bkp Printer	Yes or No		
			Auto Comp	Yes or No		
			Bkp Auto Comp	Yes or No		
			Battery	Yes or No		
			Device	Yes or No		Device corresponds to loss of communication with slave or line card.
			Line Fault	Yes or No		
			AC Power	Yes or No		
			Buffer Full	Yes or No		
Listen In	Yes or No		Listen in must be set to No for UL installations.			
Call Pending	Yes or No					
Aux Relay Cfg	Printer		Yes or No	See Section 5.3.3.7 for details. Yes = alert on trouble indication		
	Bkp Printer	Yes or No				
	Auto Comp	Yes or No				
	Bkp Auto Comp	Yes or No				
	Battery	Yes or No				
	Device	Yes or No	Device corresponds to loss of communication with slave or line card.			
	Line Fault	Yes or No				
	AC Power	Yes or No				
	Buffer Full	Yes or No				
	Listen In	Yes or No	Listen in must be set to No for UL installations.			
	Call Pending	Yes or No				

Table A-1: Programming Quick Chart (cont'd)

Program Mode Options	Choices	Choices	Choices	Choices	Comments
General Options (continued)	System Options	Battery Backup Cfg	No Battery Bkp	Yes or No	See Section 5.3.4.1 for details.
			Battery Bkp	Yes or No	See Section 5.3.4.1 for details.
			DC Bkp	Yes or No	No charging current. See Section 5.3.4.1 for details.
		Receiver Mode	MstrAuto, MstrPrn, SlvAuto, SlvPrn, or Single		
		Receiver ID	01-99		See Section 5.3.4.2 for details.
		Bad Block	Strip Bad		If this is selected an indicator will be sent to the automation computer that indicates a bad data block was received.
			Send Bad		Same as Strip Data except the bad data block is sent with the indicator.
		Auxiliary Relay	Off		See Section 5.3.4.5 for details.
			On		
		Clock Source	60 Hz		
	50 Hz				
	Internal				
	Message Queue Opt.	On	10 to 99%		Set the percentage of how full the message queue must be before a "Message Queue Warning" will occur. Default = 75%.
		Off	01 to 90 %		What percentage the queue must go back down to before "Message Queue Warning Restore" message will be sent. Default = 50%.
		Event Release	1, 20 to 120 sec.		Time from call beginning until events released to system.
	Slave List (Shown on Master Receiver Only)	Add Slave	2-digit Slave No.		Enter 8000 receiver number as a 2-digit entry.
		View Slave	S01=8000 Slave S02=8000 Slave		View 8000 receiver slave numbers.
		Delete Slave	S01=8000 Slave S02=8000 Slave		Delete 8000 receiver slave numbers.
	Virtual Receiver/Line Numbers	Receiver Number	2-digit Virtual Receiver #		See Section 5.3.7 for details.
		Line Number	3-digit Virtual Line #		See Section 5.3.7 for details.

Table A-1: Programming Quick Chart (cont'd)

Program Mode Options	Choices	Choices	Choices	Choices	Choices	Comments	
Line Device Menu	MX8000–LC3 3 Line	Add Device	Device #	Use Defaults		See Section 5.4.1 for details.	
				Copy Existing			
		Edit Line + Line #	Handshake Sequence	Handshake Sequence	Handshake Sequence	1 through 6	See Section 5.4.2.1 for details.
					Format Group	1400_2300–2, 1400Hz, 2300Hz, 2225Hz, Modem II, Modem IIE, Westec, 1400_2300Hz, or Unused	
					Handshake Duration	0-9999 in 1ms periods	
					Handshake Wait	0-9999 in 1ms periods	
					Handshake Ack Duration	0-9999 in 1ms periods	
					Pulse Format	Pulse Format	
			6-Digit Pulse	4/2, 3/2CS, 4/1CS			CS = Check Sum. If a pulse comes in a 6-digit format then the data will then be treated as the selected format.
			Inter-digit Tm (ms)	0 or 1 ms to 2 Sec.			This feature selects the time period between data blocks. See Section 5.4.2.2 for details.
			Ack on Even Round	Yes or No			If “Yes” Acknowledge only on even rounds.
			Partially Extended	Yes or No			If “Yes” you have multiple extended data blocks for 3/1 or 4/1 format.
			Line Options	Line Options	Direct	Y (yes) N (no)	Y = dedicated or direct connect phone line. N = used for standard phone lines.
					Number of Rings	0-255	See Section 5.4.2.3 for details.
					Country	USA or CRT21	
					Threshold	0-15 in 2.75VDC steps	
					Sample Time	0-90 seconds	
		Listen In	Listen In	Listen In Mode	Common, PBX, Not Used	See Section 5.4.2.4 for details.	
				PBX string edit screen	Up to 20 characters.		
				Timeout	0-255 seconds?		
				Listen In account edit screen	Add, Edit, or Clear Account.		
		Misc. Line Options	Misc. Line Options	Echo Suppress	Y (yes) N (no)	See Section 5.4.2.5 for details.	
				Caller ID	Y (yes) N (no)		
				Billing Delay	On Off		
				Hunt Group	00-99		
				Ring Options	Min Ring (15-99)		
					Max Ring (015-100)		
					Ring Off (1500-8000)		
					Min Ring Off (100-800)		
					Ring Error (0800-4400)		
		Call Hang-up	60-180 sec				

Table A-1: Programming Quick Chart (cont'd)

Program Mode Options	Choices	Choices	Choices	Choices	Choices	Comments
Line Device Menu (continued)	MX8000-LC3 3 Line (continued)	Edit Line + Line # (continued)	Ademco Auto Opt	BFSK Auto	HiSpeed or 4/2	See Section 5.4.2.6 for details
				3/1 Restore	HiSpeed or 3/1	
				4/2 Out	Normal or HiSpeed	
				FBI	S/Fast or LAR300	
				Pulse Extended	Extended or Not Ext.	
				Extended Out	HiSpeed or 4/2	
		Line Gain Opt	Transmit Gain	-3 to -14dB	See Section 5.4.2.7 for details.	
			Receive Gain	0 to 12dB in 3dB steps		
			CID Monitor	Norm, Pream, DTMF, or Marks		
			CID Gain	-6 to 7dB in steps		
			On Hook Gain	2 to 7dB in steps		
			Ringer Imped	Hi or Sy		
	Copy Device(s)	Use Defaults	Choose Device(s) #		Choose Device(s) # that you wish to be programmed to factory defaults.	
		Copy Existing	Device # of Source Device	Choose the target Device(s) #.	Copy the programming of one Device (source) and paste it into one or several (target) Device(s).	
	Clear Device(s)	Device #			See Section 5.4.6 for details.	
	View Device(s)	Device #			See Section 5.4.7 for details.	
	MX8000-LRR	Add Device	Device #	Use Defaults		See Section 5.4.1 for details.
		Edit Line + Line #	Central Station #	00-FF		
			Odd/Even Network	Odd/Even		
			VPN	Yes/No		
			A/B Network	A/B		
			Monitor Station Flag	Yes/No		
		Copy Device(s)	Use Defaults	Choose Device(s) #		Choose Device(s) # that you wish to be programmed to factory defaults.
			Copy Existing	Choose Device # of Source Device	Choose the target Device(s) #.	Copy the programming of one Device (source) and paste it into one or several (target) Device(s).
Clear Device(s)		Choose Device #			See Section 5.4.6 for details.	
View Device(s)		Choose Device #			See Section 5.4.7 for details.	
MX8000-LC1 1 Line	Add Device	Device #	Use Defaults		See Section 5.4.1 for details.	
			Copy Existing			
	Edit Line + Line #	Handshake Sequence	Handshake Sequence	1 through 6	See Section 5.4.4.1 for details.	
			Handshake Group	1400_2300-2, 1400Hz, 2300Hz, 2225Hz, Modem II, Modem IIE, Westec, 1400_2300Hz, or Unused		
			Handshake Delay	0-255 in 50ms periods		
			Handshake Duration	0-255 in 10ms periods		
			Handshake Wait	0-255 in 50ms periods		
			Handshake Ack Duration	0-255 in 10ms periods		

Table A-1: Programming Quick Chart (cont'd)

Program Mode Options	Choices	Choices	Choices	Choices	Choices	Comments			
Line Device Menu (continued)	MX8000-LC1 1 Line (continued)	Edit Line + Line # (continued)	Pulse Format	5-Digit Format	4/1, 3/2, 3/1CS	CS = Check Sum. If a pulse comes in a 5-digit format then the data will then be treated as the selected format.			
				6-Digit Pulse	4/2, 3/2CS, 4/1CS	CS = Check Sum. If a pulse comes in a 6-digit format then the data will then be treated as the selected format.			
				Inter-digit Tm (ms)	0 or 1 ms to 2 Sec.	Selects the time period between data blocks. See Section 5.4.4.2 for details.			
				Ack on Even Round	Yes or No	If "Yes" Acknowledge only on even rounds.			
				Partially Extended	Yes or No	If "Yes" you have multiple extended data blocks for 3/1 or 4/1 format.			
			Line Options	Direct	Y (yes)	N (no)	0-255	0-255 in 50ms periods	Y = dedicated or direct connect phone line. N = used for standard phone lines.
					See Section 5.4.4.3 for details.				
				Number of Rings	0-255	0-255 in 50ms periods	0-255 in 50ms periods	Select the dB level of the Handshakes and Acknowledge tone.	
				On Time	0-255				
				dB Level	Lo (Low)	Hi (High)	Md (Medium)	0-15 in 2.00VDC steps	0-255 seconds.
					Hi (High)				
					Md (Medium)				
				Threshold	0-15 in 2.00VDC steps				
			Sample Time	0-255 seconds.					
			Listen In	Listen In Mode	Common, PBX, Not Used			See Section 5.4.4.4 for details.	
				PBX string edit screen	Up to 20 characters.				
				Timeout	0-255 seconds?				
				Listen In account edit screen	Add, Edit, or Clear Account.				
			Misc. Line Options	Echo Suppress	Y (yes)	N (no)			See Section 5.4.4.5 for details.
					N (no)				
				Caller ID	Y (yes)	N (no)			
					N (no)				
				Billing Delay	On				
					Off				
			Hunt Group	00-99					
			Call Hang-up	60-180 sec					
			Ademco Auto Opt	BFSK Auto	HiSpeed or 4/2			See Section 5.4.4.6 for details.	
				3/1 Restore	HiSpeed or 3/1				
				4/2 Out	Normal or HiSpeed				
				FBI	S/Fast or LAR300				
				Pulse Extended	Extended or Not Ext.				
			Extended Out	HiSpeed or 4/2					
			Copy Device(s)	Use Defaults	Choose Device(s) #			Choose Line Device(s) # that you wish to be programmed to factory defaults.	
				Copy Existing	Choose Device # of Source Device	Choose the target Device(s) #.	Copy the programming of one Device (source) and paste it into one or several (target) Devices.		
			Clear Device	Device #			See Section 5.4.6 for details.		
			View Device	Device #			See Section 5.4.7 for details.		

Appendix B Receiver Update Procedure

A receiver update may be issued by when necessary. These updates are supplied either as a download from a web site or on floppy disk.

!WARNING!

- It is recommended that you make a printout of your programmed values for reprogramming after the update is complete. To make a printout of the programmed values, see “How to Print System Configuration” on page 4–13 and perform a Print All operation.
- The MX8000 Receiver will not accept any calls while the update procedure is being performed.

ITEMS NEEDED TO COMPLETE APPLICATION UPDATE

The following items must be available before starting the update.

- PC with available COM Port.
- 9 pin to 9 pin null modem serial cable. (Female end for Receiver Com Port.)
Note that a null modem cable will normally be required. On some computers it is possible to order the serial com port configured for a hard-wire connection. If you have exercised this option, use a normal 9 pin to 9 pin serial cable.
- Update software.

UPDATE PROCEDURE

To update the MX8000 Receiver, perform the following procedure:

1. With the MX8000 Receiver POWERED OFF, connect the null modem cable to the “COM 2” port of the Receiver and the other end to the “COM 1” port on the PC.

Note: If the COM 1 port is not available on your PC you must edit the “bat” file supplied with the update software. To edit the “bat” file, see **EDITING THE BAT FILE** on page B–2 and then continue with step 2 below.

2. From the Windows Start menu, choose the run command and then select and run the “Bat” file that is part of the update software. The screen will display:

Connect cable between PC COM1 and device.
Power up the device.

3. Power up the Receiver. The update will begin.

Notes:

- If the current application in the Receiver must be erased, the BAT file will automatically send an “erase_app.txt” file to the receiver prior to sending the update file.
- While data is being transferred, the VFD may display a message “Key Bus Trouble”. This is normal due to timing and the message will be cleared after the system reset is complete.

When the update has been transferred to the receiver, the screen will display:

Transfer Successfully Completed

4. Power off the Receiver
5. Disconnect the cable between the “COM 1” port on the PC and the “COM 2” port of the Receiver
6. Power up the Receiver
7. If instructed to do a reset in your update package, once the Receiver has completed its initialization, log onto the Receiver and select “System Reset” which is option 5 in the Installer Menu. Answer “Yes” when the system shutdown and default setting message is displayed.

EDITING THE BAT FILE

You must edit the “bat” file supplied with your upgrade software if you are not able to use the COM 1 port on your computer. To edit the bat file:

1. In Windows, load Notepad.
2. In Notepad, select “File” and then select “Open” from the drop-down menu.
3. In the Notepad “Files of type:” window select All Files.
4. Change the folder in Notepad to match the folder where your update software is stored. The “bat” file name should be displayed.
5. Select the “bat” file and the screen will appear similar to the below display.
App_Update -cCOM1 -eerase_app.txt -aP124060VB1.51.lzs
6. Edit the -cCOM1 command to match the COM port you are using. (DO NOT DELETE the -c as it defines the that the following characters are the COM port name.) For example, if you are using COM port 2, your display will be similar to the below display.
App_Update -cCOM2 -eerase_app.txt -aP124060VB1.51.lzs
7. Do a File Save in Notepad and then do a File Exit. Your modified “bat” file is ready for use.
8. Return to the **UPDATE PROCEDURE** on page B-1.

Appendix C Index

240 VAC	3-9	Default User Codes	4-5
3/1 Restore Out		delete a user	5-72
MX8000-LC1	5-66	Delete Slave	5-26
MX8000-LC3	5-49	Direct Line	
4/2 Out		MX8000-LC1	5-59
MX8000-LC1	5-66	MX8000-LC3	5-41
MX8000-LC3	5-49	Disable Line Device	5-41, 5-59
Accessories	1-1	Display options	5-7
ACKing		earth ground	3-10
ADEMCO 8000	8-9	Edit Line Device	
ITI Generic	8-32	MX8000-LC1	5-55
SK9000	8-28	MX8000-LC3	5-37
Acknowledge Time	5-18	MX8000-LRR	5-52
Acknowledge Tone Duration Time		Event Release	5-25
MX8000-LC1	5-57	Extended Out	
MX8000-LC3	5-39	MX8000-LC1	5-67
Add Slave	5-25	MX8000-LC3	5-50
ADEMCO 8000	8-3	FBII Out	
ACKing	8-9	MX8000-LC1	5-66
Bad Data	8-6	MX8000-LC3	5-49
Dialer format	8-4	FCC Registration Number	2-1
NACKing	8-9	Features	1-1
Annunciator	5-13	firmware information	4-9
Automatic operation	5-6	Format Group	
Automation Communication Format	5-16, 8-1	MX8000-LC1	5-56
Automation Computer Connection	3-12	MX8000-LC3	5-39
Automation Configuration	5-12, 5-13	Formats	1-2
Automation Protocols	8-1	Fuse	3-1
Auxiliary Relay	3-1, 5-14, 5-20, 5-21, 5-23	General Options	5-2
Backup Battery		General Options Items	5-3
Configuration	5-21	Grounding	3-10
Connection	3-11	Handshake Delay	
Setting	5-21	MX8000-LC1	5-56
Bad Data	8-27	Handshake Duration	
ADEMCO 8000	8-6	MX8000-LC1	5-57
SK9000	8-27	MX8000-LC3	5-39
BFSK Auto Out		Handshake Sequence	
MX8000-LC1	5-66	MX8000-LC1	5-56
MX8000-LC3	5-48	MX8000-LC3	5-38
Call Hang-up	5-48, 5-65	Handshake Wait	
Call Message	8-3	MX8000-LC1	5-57
Caller ID		MX8000-LC3	5-39
MX8000-LC1	5-64	Hang-Up	8-11
MX8000-LC3	5-46	Heartbeat	5-17, 8-8
Calls From Panels	8-26	hexadecimal values	8-1
checksum/control field	8-37	Hold Last Event	5-8, 5-10
CID Gain		Initialization string (Init string)	5-15
MX8000-LC3	5-51	ITI Computer Information Format	5-18
CID Monitor		ITI Computer Interface Format	8-32
MX8000-LC3	5-51	ITI Formats	5-19
Clock Synchronization	5-23	ITI Generic	5-18, 8-29, 8-30
Com Port 1	3-12, 5-11, 5-14	ACKing	8-32
Com Port 2	5-11, 5-12, 5-15	NACKing	8-32
communication option	5-11	ITI Panels	5-19
computer port baud rate	3-12	Language	5-7
Condition Codes	8-36	Language Display	5-8
Configure Printer	4-15	LED	4-3
Country		Line Card Installation	3-5
MX8000-LC3	5-42	Line Device	5-27, 5-37
Current Draw	3-1	Disable	5-41, 5-59
Data String	8-25	Line Options	
Date Display	5-7	MX8000-LC1	5-59
Date Format Display	5-9	MX8000-LC3	5-41
Daylight Savings	5-7, 5-9	Line Voltage	3-1
Dedicated Line		Link Test	8-13, 8-29
MX8000-LC1	5-59	Listen-in	4-19, 8-5
MX8000-LC3	5-41	ADEMCO 8000	8-11, 8-12

Listen-in Add		Programming	5-1
MX8000-LC1	5-63	Programming Choices	5-2
MX8000-LC3	5-44	Programming Fields	5-1
Listen-in Clear		Pulse Extended	
MX8000-LC1	5-63	MX8000-LC1	5-67
MX8000-LC3	5-45	MX8000-LC3	5-49
Listen-in Edit		Quick Start	3-1
MX8000-LC1	5-63	Receive Line Gain	
MX8000-LC3	5-45	MX8000-LC3	5-50
Log Off	4-5, 4-6	Receiver ID	4-9, 5-21, 5-22
Log On	4-5	Receiver Master	5-22
Log only operation	5-6	Receiver Single	5-22
Log Record	8-31, 8-37	Receiver Slave	5-22
Long Call	8-6, 8-26	Record Structure	8-33
Main Menu	4-7	Report Record	8-33
Main Menu Option Items by Profile	4-5	Ring Off Time	
Maneuver Around in Program Mode	5-1	MX8000-LC1	5-60
Maneuver Through Main Menu	4-8	Ring On Time	
Manual (Common) Listen-in	4-19	MX8000-LC1	5-60
Manual operation	5-6	Ring Threshold	
master/slave receiver linking	3-12	MX8000-LC1	5-60
model number	4-9	MX8000-LC3	5-42
NACKing		Ringer Impedance	
ADEMCO 8000	8-9	MX8000-LC3	5-52
ITI Generic	8-32	Set Time & Date	4-9
SK9000	8-28	SK9000	
No Data Received	7-4	ACKing	8-28
Normal mode	4-6	Bad Data	8-27
Null Modem Cable		NACKing	8-28
25-Pin	3-12	Slave Add	5-25
9-Pin	3-12	Slave Delete	5-26
Number of Rings		Slave List	5-25
MX8000-LC1	5-59	Slave View	5-26
MX8000-LC3	5-41	software date code	4-9
OKAY Record	8-32	software revision	4-9
On Hook Gain		Supervisory Character	5-19
MX8000-LC3	5-52	System History	4-9
On-board Annunciator	5-19	System Info	4-9
Operation mode	5-6	System Message	8-7, 8-28
Panel data	8-4	System Options	5-21
Panel Type Characters	8-35	Test Record	8-29
Parallel Port	5-12	Testing	4-20
PBX	4-20	Threshold	
PBX String	4-20, 8-12	MX8000-LC1	5-60
Phone Line Sample Rate		MX8000-LC3	5-42
MX8000-LC1	5-61	Time Display	5-7
PIN	1-4, 4-5, 5-70, 5-71, 5-72	Time Format Display	5-9
Port Function	5-4, 5-11, 5-14	Touchpad Buttons	4-2
Power Up	4-4	Transmit Line Gain	
Print a Test Page	4-13	MX8000-LC3	5-50
Print Call History	4-12	User List	5-70
Print Line Card Statistics	4-14	V-Byte	8-9, 8-27
print menu	4-11	VFD	4-3
Print Report	4-12	VFD Brightness	5-10
Print System Configuration	4-13	View Slave	5-26
Print System History	4-12	Virtual Line	5-26
printer cable	3-8	Virtual Receiver	5-26
Program Menu	4-15		

NOTES

NOTES

LIMITED WARRANTY

Honeywell International Inc., acting through its Security & Custom Electronics business ("Seller") 165 Eileen Way, Syosset, New York 11791, warrants its product(s) to be in conformance with its own plans and specifications and to be free from defects in materials and workmanship under normal use and service for 24 months from the date stamp control on the product(s) or, for product(s) not having a manufacturer's date stamp, for 12 months from date of original purchase unless the installation instructions or catalog sets forth a shorter period, in which case the shorter period shall apply. Seller's obligation shall be limited to repairing or replacing, at its option, free of charge for materials or labor, any product(s) which is proved not in compliance with Seller's specifications or proves defective in materials or workmanship under normal use and service. Seller shall have no obligation under this Limited Warranty or otherwise if the product(s) is altered or improperly repaired or serviced by anyone other than Honeywell factory service. For warranty service, return product(s) transportation prepaid, to Honeywell Factory Service, 165 Eileen Way, Syosset, New York 11791.

THERE ARE NO WARRANTIES, EXPRESS OR IMPLIED, OF MERCHANTABILITY, OR FITNESS FOR A PARTICULAR PURPOSE OR OTHERWISE, WHICH EXTEND BEYOND THE DESCRIPTION ON THE FACE HEREOF. IN NO CASE SHALL SELLER BE LIABLE TO ANYONE FOR ANY CONSEQUENTIAL OR INCIDENTAL DAMAGES FOR BREACH OF THIS OR ANY OTHER WARRANTY, EXPRESS OR IMPLIED, OR UPON ANY OTHER BASIS OF LIABILITY WHATSOEVER, EVEN IF THE LOSS OR DAMAGE IS CAUSED BY THE SELLER'S OWN NEGLIGENCE OR FAULT.

Seller does not represent that the product(s) it sells may not be compromised or circumvented; that the product(s) will prevent any personal injury or property loss by burglary, robbery, fire or otherwise; or that the product(s) will in all cases provide adequate warning or protection. Customer understands that a properly installed and maintained alarm system may only reduce the risk of a burglary, robbery, fire, or other events occurring without providing an alarm, but it is not insurance or a guarantee that such will not occur or that there will be no personal injury or property loss as a result. **CONSEQUENTLY, SELLER SHALL HAVE NO LIABILITY FOR ANY PERSONAL INJURY, PROPERTY DAMAGE OR OTHER LOSS BASED ON A CLAIM THAT THE PRODUCT(S) FAILED TO GIVE WARNING. HOWEVER, IF SELLER IS HELD LIABLE, WHETHER DIRECTLY OR INDIRECTLY, FOR ANY LOSS OR DAMAGE ARISING UNDER THIS LIMITED WARRANTY OR OTHERWISE, REGARDLESS OF CAUSE OR ORIGIN, SELLER'S MAXIMUM LIABILITY SHALL NOT IN ANY CASE EXCEED THE PURCHASE PRICE OF THE PRODUCT(S), WHICH SHALL BE THE COMPLETE AND EXCLUSIVE REMEDY AGAINST SELLER.**

This warranty replaces any previous warranties and is the only warranty made by Seller on this product(s). No increase or alteration, written or verbal, of the obligations of this Limited Warranty is authorized.

Honeywell

165 Eileen Way, Syosset, New York 11791
Copyright © 2004 Honeywell International Inc.

www.honeywell.com/security



K5982V1 11/03 Rev. A